

Application and Design

The SEVCD-33 is a severe environment 316SS ultra low leakage control damper with rugged stainless steel airfoil blades designed to meet the highest standards established for commercial control dampers. The SEVCD-33 is intended for application in medium to high pressure and velocity systems. This model also IECC (International Energy Consumption Code) compliant with a leakage rating of 3 cfm/ft² @ 1 in. wg (55 cmh/m² @ .25 kPa) or less.

Ratings (See page 3 for specific limitations)

- Pressure:** 10 in. wg (2.5 kPa) pressure differential.
- Velocity:** 2500 to 4000 fpm (12.7 m/s-20.3 m/s)
- Leakage:** Class 1A @ 1 in. wg (.25 kPa)
Class 1 @ 4 in. - 10 in. wg (1 kPa - 2.5 kPa)
- Temperature:** 180°F to 250°F (82°C to 121°C). Consult Greenheck for higher temperatures

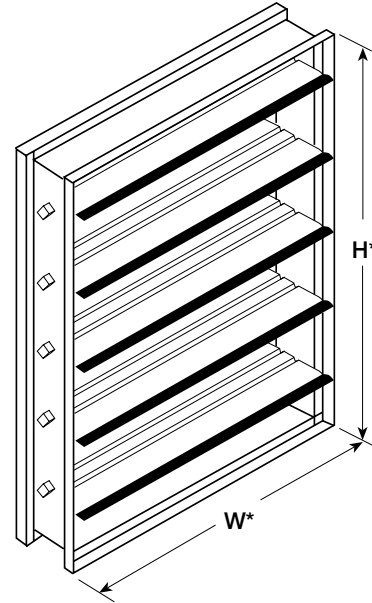

	Standard Construction	Optional Construction
Frame Material	316 stainless steel	-
Frame Material Thickness	16 ga. (1.5mm)	-
Frame Type	5 in. x 1in. (127mm x 25mm) hat channel	Single flange Single Reversed flange Double flange
Blade Action	Opposed	Parallel
Blade Material	316 stainless steel	-
Blade Material Thickness	14 ga. (2mm) equiavent	-
Blade Type	Airfoil	-
Linkage	316SS	-
Axle Bearings	316SS	-
Axle Material	316SS	-
Blade Seals	TPE	Silicone
Jamb Seals	316SS	-

*W & H dimension furnished approximately 1/4 in. (6mm) undersize.

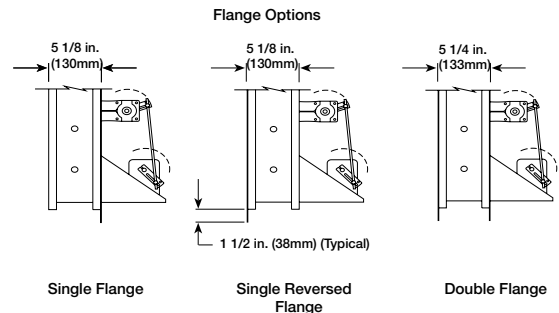

Size Limitations

W x H	Minimum Size	Maximum Size	
		Single Section	Multi-Section
Inches	6 x 6	74 x 60	Unlimited
mm	152 x 152	1880 x 1524	

Blade Operation

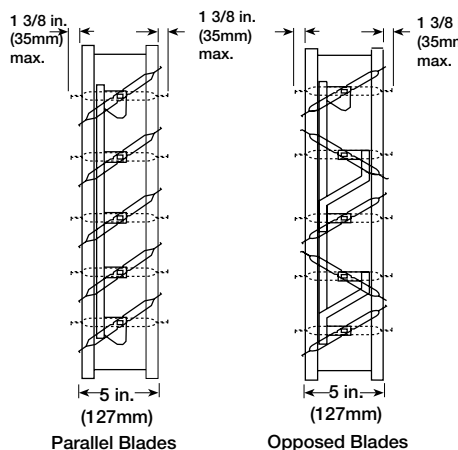

Features & Options

- Airfoil shape reduces pressure drop and turbulence at velocities to 4000 fpm (20.3 m/s).
- Frames are constructed with reinforced corners. Low profile head and sill are used on sizes less than 17 in. (432mm).
- Removable control shaft extends 6 in. (152mm) beyond frame.
- Actuators (120V, 24V, 230V, Pneumatic or Manual Quadrant)
- Face & Bypass
- OCI (Open Close Indicator)
- Retaining Angles
- Silicone blade seal -60°F to 350°F (-51°C to 177°C) temperature rating
- Sleeves
- Transitions (R, C, O)

This pressure drop testing was conducted in accordance with AMCA Standard 500-D using the three configurations shown. All data has been corrected to represent standard air at a density of .075 lb/ft³ (1.2 kg/m³).

Actual pressure drop found in any HVAC system is a combination of many factors. This pressure drop information along with an analysis of other system influences should be used to estimate actual pressure losses for a damper installed in a given HVAC system.

AMCA Test Figures

Figure 5.2 Illustrates a ducted damper exhausting air into an open area. This configuration has a lower pressure drop than Figure 5.5 because entrance losses are minimized by a straight duct run upstream of the damper.

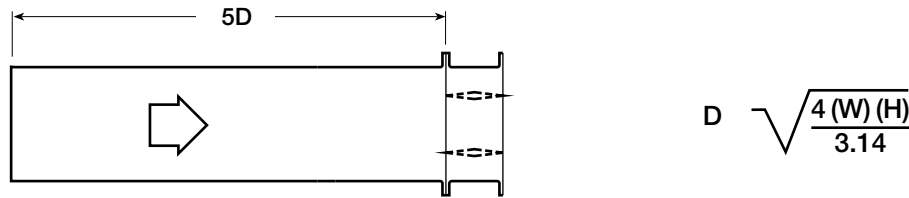

Figure 5.3 Illustrates a fully ducted damper. This configuration has the lowest pressure drop of the three test configurations because entrance and exit losses are minimized by straight duct runs upstream and downstream of the damper.

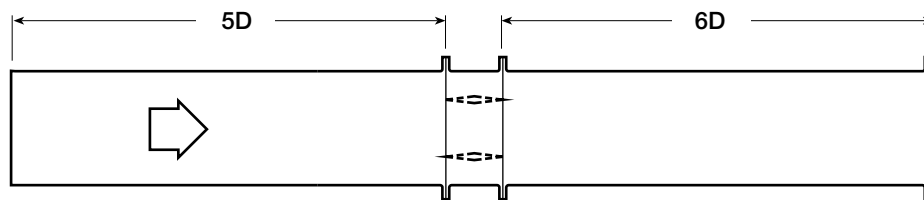
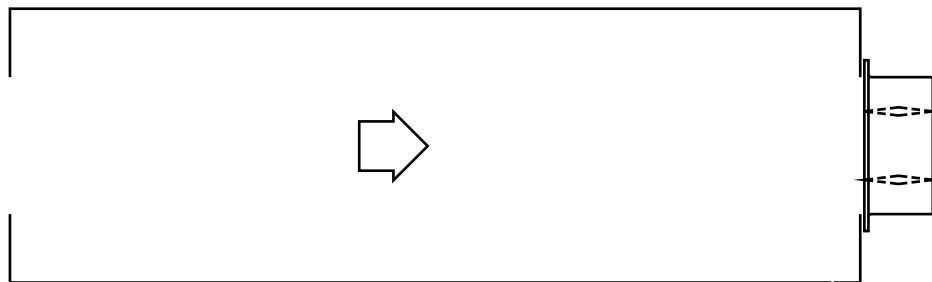

Figure 5.5 Illustrates a plenum mounted damper. This configuration has the highest pressure drop because of extremely high entrance and exit losses due to the sudden changes of area in the system.





Greenheck Fan Corporation certifies that the model SEVCD-33 shown herein is licensed to bear the AMCA Seal. The ratings shown are based on tests and procedures performed in accordance with AMCA Publication 511 and comply with the requirements of the AMCA Certified Ratings Programs. The AMCA Certified Ratings Seal applies to Air Leakage and Air Performance ratings.

AMCA 5.2

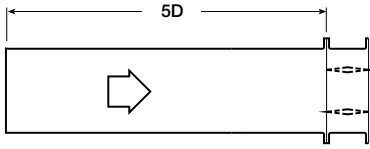

12 in. x 12 in. (305mm x 305mm)

Velocity (fpm)	Pressure Drop (in. wg)
500	0.01
1000	0.03
1500	0.07
2000	0.13
2500	0.19
3000	0.26
3500	0.35
4000	0.45

24 in. x 24 in. (610mm x 610mm)

Velocity (fpm)	Pressure Drop (in. wg)
500	0.01
1000	0.03
1500	0.06
2000	0.10
2500	0.15
3000	0.21
3500	0.28
4000	0.36

36 in. x 36 in. (914mm x 914mm)

Velocity (fpm)	Pressure Drop (in. wg)
500	0.01
1000	0.02
1500	0.04
2000	0.07
2500	0.11
3000	0.15
3500	0.20
4000	0.26

12 in. x 48 in. (305mm x 1219mm)

Velocity (fpm)	Pressure Drop (in. wg)
500	0.01
1000	0.03
1500	0.07
2000	0.11
2500	0.17
3000	0.23
3500	0.31
4000	0.39

48 in. x 12 in. (1219mm x 305mm)

Velocity (fpm)	Pressure Drop (in. wg)
500	0.01
1000	0.02
1500	0.04
2000	0.08
2500	0.12
3000	0.16
3500	0.21
4000	0.27

AMCA 5.3

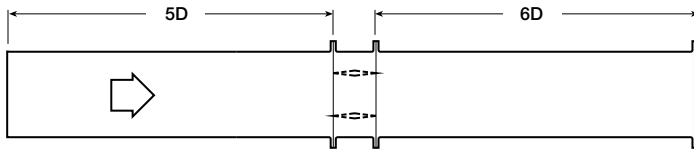

12 in. x 12 in. (305mm x 305mm)

Velocity (fpm)	Pressure Drop (in. wg)
500	0.01
1000	0.02
1500	0.05
2000	0.08
2500	0.12
3000	0.17
3500	0.23
4000	0.30

24 in. x 24 in. (610mm x 610mm)

Velocity (fpm)	Pressure Drop (in. wg)
500	0.01
1000	0.01
1500	0.03
2000	0.05
2500	0.09
3000	0.13
3500	0.17
4000	0.22

36 in. x 36 in. (914mm x 914mm)

Velocity (fpm)	Pressure Drop (in. wg)
500	0.01
1000	0.01
1500	0.02
2000	0.04
2500	0.06
3000	0.08
3500	0.12
4000	0.15

12 in. x 48 in. (305mm x 1219mm)

Velocity (fpm)	Pressure Drop (in. wg)
500	0.01
1000	0.02
1500	0.04
2000	0.08
2500	0.12
3000	0.17
3500	0.22
4000	0.29

48 in. x 12 in. (1219mm x 305mm)

Velocity (fpm)	Pressure Drop (in. wg)
500	0.01
1000	0.02
1500	0.04
2000	0.07
2500	0.11
3000	0.15
3500	0.20
4000	0.25

AMCA 5.5

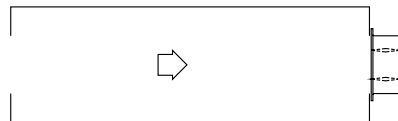

12 in. x 12 in. (305mm x 305mm)

Velocity (fpm)	Pressure Drop (in. wg)
500	0.03
1000	0.12
1500	0.27
2000	0.48
2500	0.74
3000	1.07
3500	1.46
4000	1.91

24 in. x 24 in. (610mm x 610mm)

Velocity (fpm)	Pressure Drop (in. wg)
500	0.03
1000	0.11
1500	0.26
2000	0.45
2500	0.71
3000	1.02
3500	1.40
4000	1.89

36 in. x 36 in. (914mm x 914mm)

Velocity (fpm)	Pressure Drop (in. wg)
500	0.02
1000	0.09
1500	0.21
2000	0.38
2500	0.58
3000	0.85
3500	1.15
4000	1.52

12 in. x 48 in. (305mm x 1219mm)

Velocity (fpm)	Pressure Drop (in. wg)
500	0.03
1000	0.11
1500	0.24
2000	0.43
2500	0.67
3000	0.96
3500	1.31
4000	1.71

48 in. x 12 in. (1219mm x 305mm)

Velocity (fpm)	Pressure Drop (in. wg)
500	0.03
1000	0.11
1500	0.24
2000	0.44
2500	0.68
3000	0.97
3500	1.32
4000	1.73

Air leakage is based on operation between 32°F (0°C) and 120°F (49°C).

Tested for leakage in accordance with ANSI/AMCA Standard 500-D, Figure 5.5.

Tested for air performance in accordance with ANSI/AMCA Standard 500-D, Figures 5.2, 5.3 and 5.5.

Torque

Data are based on a torque of 7.0 in.lb./ft² (0.79 N·m) applied to close and seat the damper during the test.

SEVCD-33	Leakage Class		
Maximum Damper Width	1 in. wg (0.25 kPa)	4 in. wg (1 kPa)	8 in. wg (2 kPa)
60 in. (1524mm)	1A	1	NA



Greenheck Fan Corporation certifies that the model SEVCD-33 shown herein is licensed to bear the AMCA Seal. The ratings shown are based on tests and procedures performed in accordance with AMCA Publication 511 and comply with the requirements of the AMCA Certified Ratings Programs. The AMCA Certified Ratings Seal applies to Air Leakage and Air Performance ratings.

*Leakage Class Definitions

The *maximum* allowable leakage is defined by AMCA as the following:

- Leakage Class 1A - 3 cfm/ft² @ 1 in. wg (class 1A is only defined at 1 in. wg).
- Leakage Class 1
 - 4 cfm/ft² @ 1 in. wg
 - 8 cfm/ft² @ 4 in. wg
 - 11 cfm/ft² @ 8 in. wg
 - 12.6 cfm/ft² @ 10 in. wg

Velocity Limitations

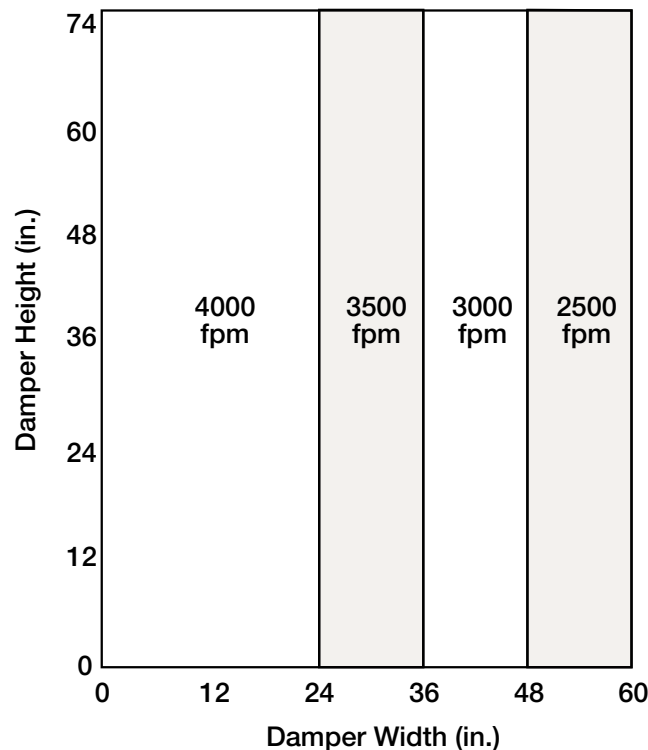

Multi-Section Assembly

Dampers larger than the maximum single section size, will be made up of a multiple of equal size sections. Multiple section dampers can be jackshafted together so that all sections operate together as shown below.

NOTE: Dampers larger than 60 in. x 74 in. (1524mm x 1880mm) are not intended to be structurally self supporting. Additional horizontal bracing is recommended to support the weight of the damper and vertical bracing should be installed as required to hold against system pressure.

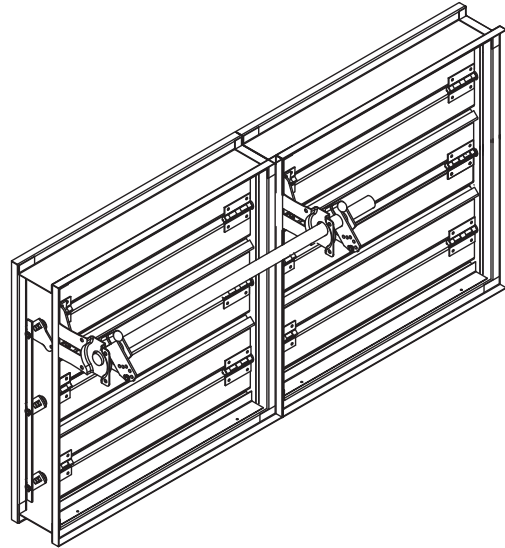

Face and Bypass Configurations

SEVCD-33 series control dampers can be assembled for face and bypass configurations. Face and bypass dampers are available in vertical, horizontal and right angle arrangements as shown below.

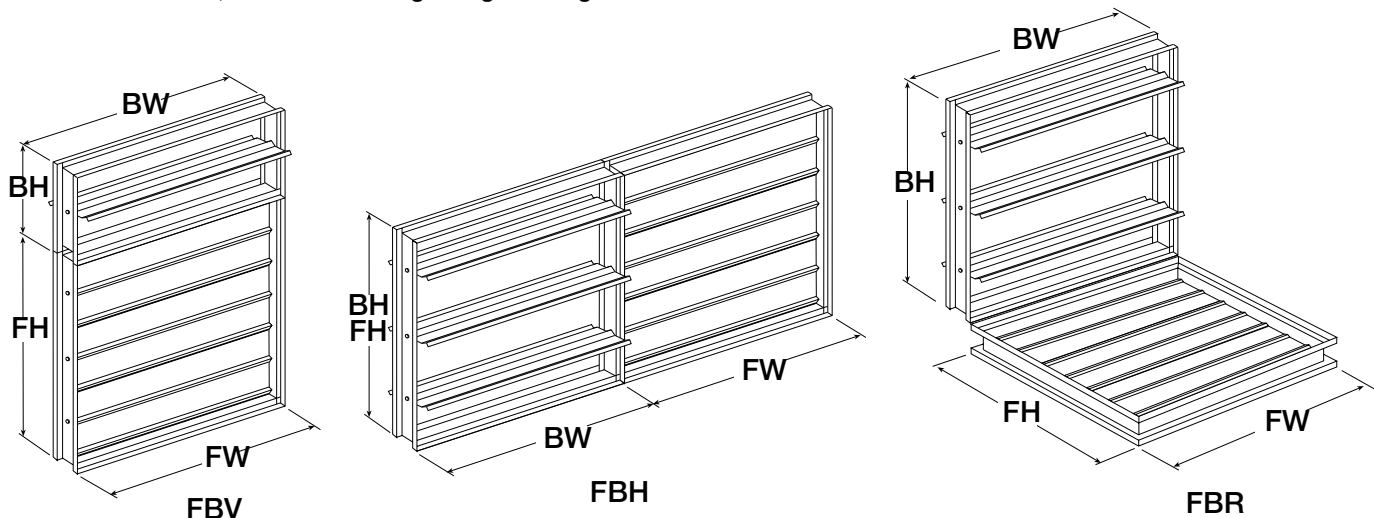

Specifications

Control dampers meeting the following specifications shall be furnished and installed where shown on plans and/or as described in schedules.

Dampers shall consist of: a 16 ga. (1.5mm) 316 stainless steel channel frame with 5 in. (127mm) depth; airfoil shaped, 316 stainless steel double skin construction blades (14 ga. [2mm] equivalent thickness); blades shall be completely symmetrical relative to their axle pivot point, presenting identical resistance to airflow in either direction or pressure on either side of the damper; 1/2 in. (6mm) dia. 316 stainless steel axles turning in 316 stainless steel sleeve bearings; TPE blade seals for 200°F (93°C) maximum temperature; flexible 316 stainless steel jamb seals; and external (out of the airstream) blade-to-blade linkage.

Damper manufacturer's printed application and performance data including pressure, velocity and temperature limitations shall be submitted for approval showing damper suitable for pressures to 10 in. wg (2.5 kPa), velocities to 4000 fpm (20.3 m/s) and temperatures to 250°F (121°C). Testing and ratings to be in accordance with AMCA Standard 500-D.

Basis of design is Greenheck model SEVCD-33.

Specifier has following options:

Damper manufacturer's printed performance data showing standard air leakage less than 6 cfm/sq. ft. @ 4 in. wg (110 cmh/m² @ 1 kPa) shall be submitted for approval. Testing and ratings shall be per AMCA Standard 500-D.

