

Application and Design

Model RBD-10 is a remote powered balancing damper designed to regulate the flow of air in a HVAC system. This balancing damper is ideal for applications where it is difficult to get access to manually adjust the dampers and balance the airflow. The 'EZ Balance' hand held remote (equipped with 9 volt power supply) operates the damper actuator when connected to the diffuser connector or wall/ceiling plate.

Ratings:

- Pressure: 1 in. wg (.25 kPa) - pressure differential
- Velocity: 2000 fpm (10.2 m/s)
- Temperature: 180° F (82°C)

Standard Construction:

- Frame: Reinforced 18 ga. (1.3mm) galvanized steel
- Blade: 20 ga. (1mm) galvanized steel
- Operator: 9 volt actuator (shipped as a kit for field installation)
- Axles: Integral 1/2 in. (13mm) dia.

Size Limitations

- Minimum size: 6 in. W x 4 in. H (152mm x 152mm)
- Maximum size: 36 in. W x 12 in. H (914mm x 305mm)

Options:

- Diffuser connectors
- Single gang wall plates with ports (1,2, 3, 4 or 6 port)
 - Colors: white, ivory, or stainless steel
- Round wall/ceiling mounting plate with one port
- Single gang outlet box
- 'EZ Balance' remote control device (9 volt battery and 5 foot (1524mm) of cable included)
- 5, 14, 25 or 50 foot (1524, 4267, 7620 or 15,240mm) non-plenum rated cable
- 14, 25 or 50 foot (4267, 7620 or 15,240mm) plenum rated cable
- Cable connectors

Note:
All wire connections are made with prewired RJ11 plugs and sockets. No additional wiring or tools required.

Note: Utilizing any controller other than 'EZ Balance' remote to adjust the RBD-10 damper voids the actuator warranty.



*W & H dimension furnished approximately 1/4 in. (6mm) undersize.

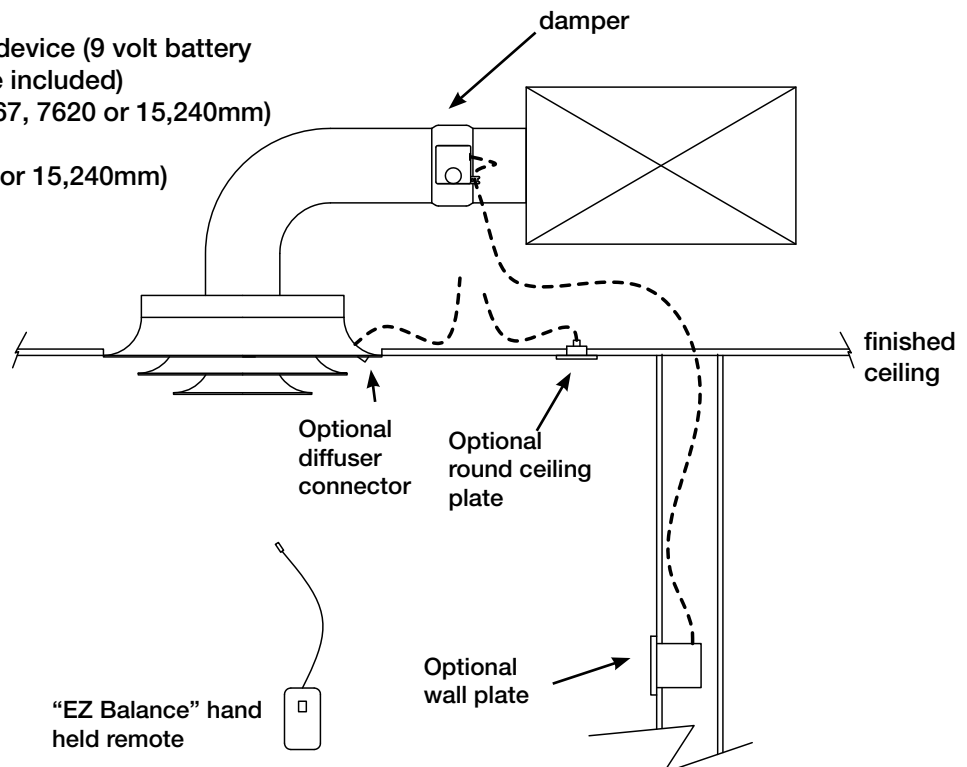

Installation instructions available at www.greenheck.com

Dimensional Drawings

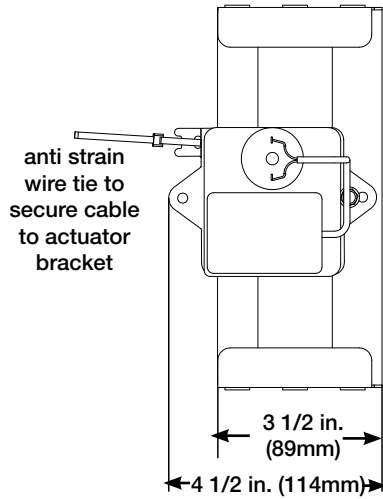

Side view
Actuator field installed.

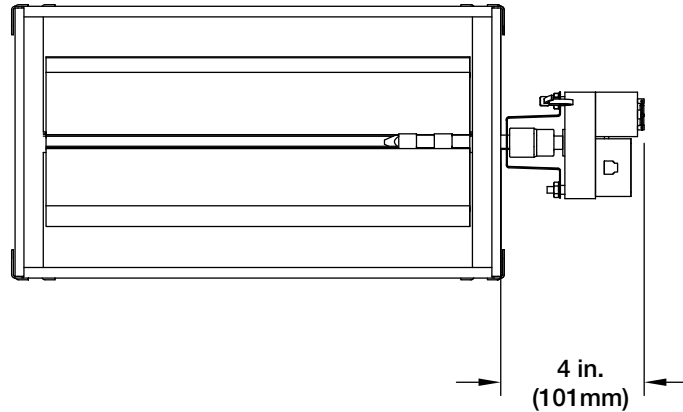

Front view
Actuator field installed

Wall plates with ports

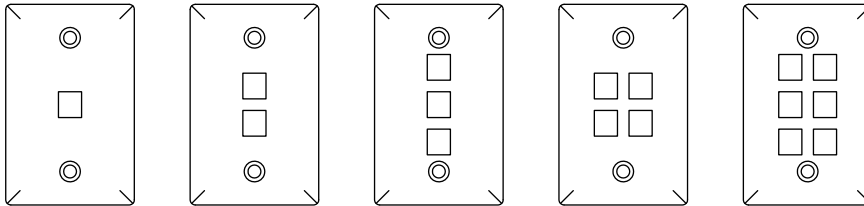

One Port

Two Ports

Three Ports

Four Ports

Six Ports

White, ivory and almond wall plate dimension is 3 1/4 in. x 4 3/4 in. (83mm x 121mm).
Stainless steel wall plate dimension is 2 3/4 in. x 4 1/2 in. (70mm x 114mm).

Single gang box

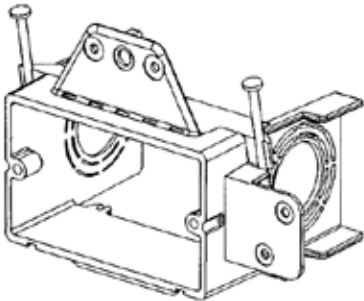

Round wall/ceiling plate



3 1/4 in. (83mm) diameter

EZ Balance remote



Specifications

Remote balancing dampers meeting the following specifications shall be furnished and installed where shown on plans and/or as described in schedules.

Dampers shall consist of: a 18 ga. (1.3mm) galvanized steel frame with 3 1/2 in. (89mm) depth; blades fabricated from 20 ga. (1mm) galvanized steel; integral 1/2 in. (13mm) dia. axles. Damper shall be supplied with 9 volt actuator kit (field installed). All wire connections

to be made using RJ11 plugs and sockets, no additional wiring or tools are needed.

Dampers shall be suitable for pressures up to 1 in. wg (.25 kPa), velocities up to 2000 fpm (10.2 m/s) and temperatures up to 180°F (82°C). Testing and ratings to be in accordance with AMCA Standard 500-D.

Basis of design is Greenheck's RBD-10.



P.O. Box 410 • Schofield, WI 54476-0410 • 715.359.6171 • greenheck.com

Copyright © 2010 Greenheck Corporation
RBD-10 Rev 2 July 2010