

## Bubble Tight Isolation Damper

### Application and Design

The HBTR-151 is an isolation damper designed for isolation and decontamination applications. The damper has bubble tight leakage performance per AMCA 500-D up to 10 in. wg (2.5 kPa). The damper frame is flanged for easy mounting and the blade seal is mechanically fastened to the blade.

### Ratings

**Leakage:** Bubble tight per AMCA 500-D

**Pressure:** 10 in. wg (2.5 kPa) - differential pressure

**Velocity:** 3900 fpm (19.8 m/s)

**Temperature:** 250°F (121°C) maximum  
-40° F (C) minimum

Construction	Standard	Optional
Frame Material	Painted Steel	304SS or 316SS
Frame Thickness	12 ga. (2.7mm)	
Frame Type	Flanged Channel	
Blade Material	Painted Steel	304SS or 316SS
Blade Type	Round, center pivoted, double skin	
Blade Thickness	12 ga. (2.7mm)	
Blade Seals	Silicone rubber, mechanically fastened	
Blade Stop	full-open and full-close pin stops	
Axle	Full length round 1/2 in. (12.7mm) axle on damper sizes up to 12 in. (305mm) diameter; round 3/4 in. (19mm) axle on damper sizes above 12 in. (305mm) diameter	
Axle Material	Painted Steel	303SS or 316SS
Axle Seal	Double gland	
Bearings	Relubricable ball, outboard mounting	
Paint Finish	Permatector™	Epoxy, Hi Pro Polyester, Industrial Epoxy, Mill finish (304SS or 316SS)

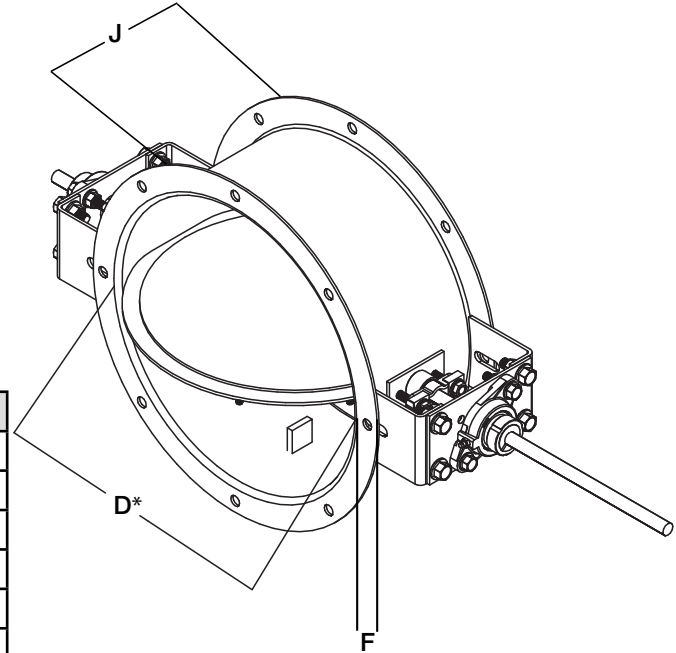

\* Actual Inside Dimension

### Available Sizes:

**Minimum Size:** 6 in. (152mm) diameter

**Maximum Size:** 24 in. (610mm) diameter

### Options Available:

- Bolt holes in flanges
- Actuators
- Limit switches
- Special construction available

Diameter (D) Inches (mm)		Frame Depth J Inches (mm)	Frame & Flange gauge (mm)	Flange Width F Inches (mm)	Axle Diameter Inches (mm)	Blade Thickness gauge (mm)
Above	Through					
6 (152)	12 (305)	6 (152)	12 (2.7)	1.5 (38)	0.5 (13)	12 (2.7)
12 (305)	24 (610)	8 (203)	12 (2.7)	1.5 (38)	0.75 (19)	12 (2.7)

## AMCA Test Figure 5.3

Figure 5.3 illustrates a fully ducted damper. This configuration has low pressure drop because entrance and exit losses are minimized by straight duct runs upstream and downstream of the damper.

AMCA Test Figure 5.3

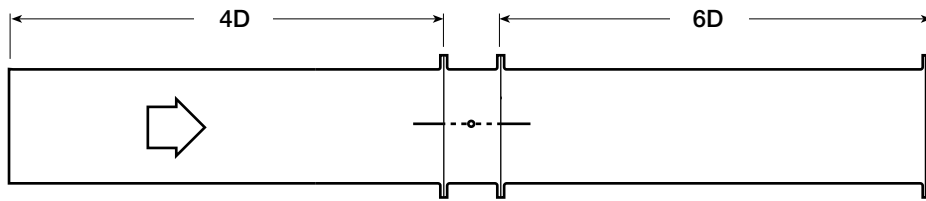

## Pressure Drop Data

This pressure drop data was conducted in accordance with AMCA Standard 500-D using Test Figure 5.3. All data has been corrected to represent standard air at a density of 0.075 lb/ft<sup>3</sup> (1.2 kg/m<sup>3</sup>).

Actual pressure drop found in any HVAC system is a combination of many factors. This pressure drop information along with an analysis of other system influences should be used to estimate actual pressure losses for a damper installed in a given HVAC system.

## Leakage

Every HBTR-151 is leakage tested at 10 in. wg (2.5kPa) in accordance with AMCA 500-D before it leaves the factory. Greenheck does not ship a HBTR-151 unless it meets the requirements of the standard.

Pressure Drop  
12 in. (305mm) dia. Damper

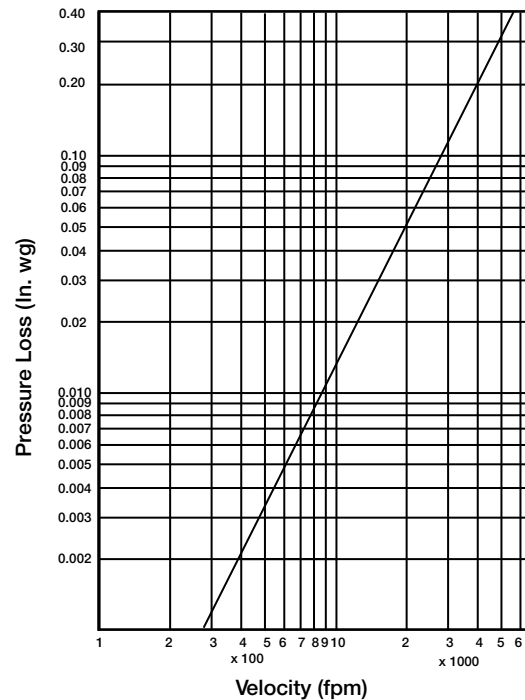

## Bearing Detail

The ball bearings are mounted outboard for easy access. The bearing comes with a grease fitting, allowing for easy lubrication (axle seals included but not shown in bearing detail).

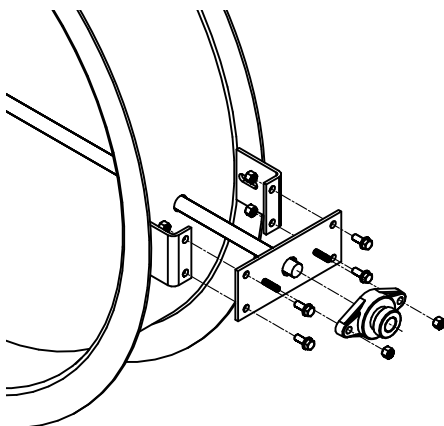

## Axle Seal Detail

The double gland axle seal is mounted externally for easy access and provides bubble tight performance.

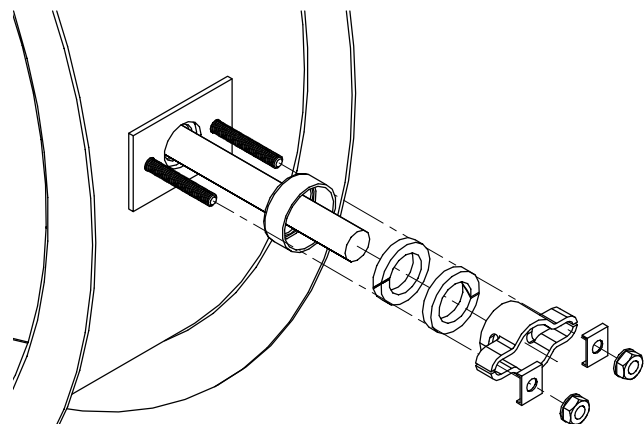

## Frame Construction Options

### Bolt Holes:

- Standard - Does not include bolt holes
- Optional - Bolt holes in both flanges.

Greenheck recommended bolt hole pattern is shown in the table below. Customer must specify bolt holes that are parallel to the axle centerline (P) or that straddle the axle centerline (S) as shown in the diagrams below. Greenheck can also provide bolt hole sizes and patterns other than those shown below.

Bolt Holes  
Parallel to Axle Centerline (P)

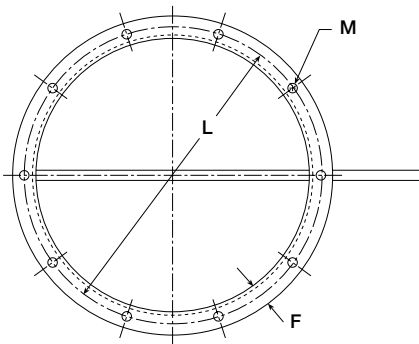

Bolt Holes  
Straddle Axle Centerline (S)

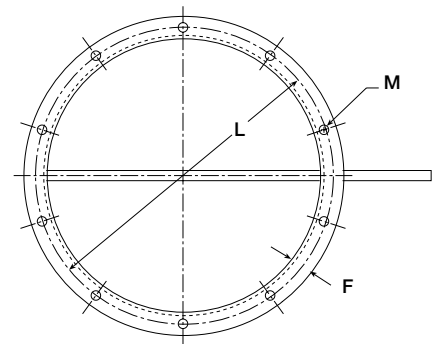

Greenheck Recommended Bolt Hole Pattern  
(Bolt Holes Parallel to Axle Centerline)

Diameter Inches (mm)		Number of Holes	Mounting Hole Diameter in. (mm) (M)	Bolt Circle Diameter (L)	Degrees Between Holes
Above	Through				
5.99 (152)	11 (279)	6	7/16 (11)	*	60
11 (279)	18 (457)	8	7/16 (11)	*	45
18 (457)	24 (610)	12	7/16	*	30
* Bolt Circle Diameter = Damper Diameter + Flange Height + 1/4 in.					

All dimensions shown are in inches.

## Specifications

Industrial grade isolation dampers meeting the following specifications shall be furnished and installed where shown on plans and/or as described in schedules.

Damper shall consist of round and flanged frame, full length axle, double skin blade, solid silicone blade seal, double gland axle seal and outboard ball bearings. Blade seal shall be mechanically fastened to the blade and be field replaceable. Blade shall be welded to the axle. Bearing shall be bolted to outboard mounting plates and shall include a grease fitting for relubrication. Double gland stuffing box shall prevent leakage around the axle.

Each damper shall be tested in accordance to AMCA Standard 500-D Bubble Tight Test at 10 in. wg prior to shipping.

Damper manufacturer's printed application and performance data including pressure, and velocity limitations shall be submitted for approval showing damper suitable for pressures to 10 in. wg (2.5 kPa), velocities to 3900 fpm, (19.8 m/s) and temperatures to 250°F (121°C) maximum.

Frame gauges, blade gauges, and axle diameters shall be equal to or exceed those of the model which is the basis of design.

Basis of design is Greenheck model HBTR-151.

