

## Installation, Operation and Maintenance Manual

Please read and save these instructions for future reference. Read carefully before attempting to assemble, install, operate or maintain the product described. Protect yourself and others by observing all safety information. Failure to comply with instructions could result in personal injury and/or property damage!

### As used in Greenheck models

- DGX
- IGX
- MSX

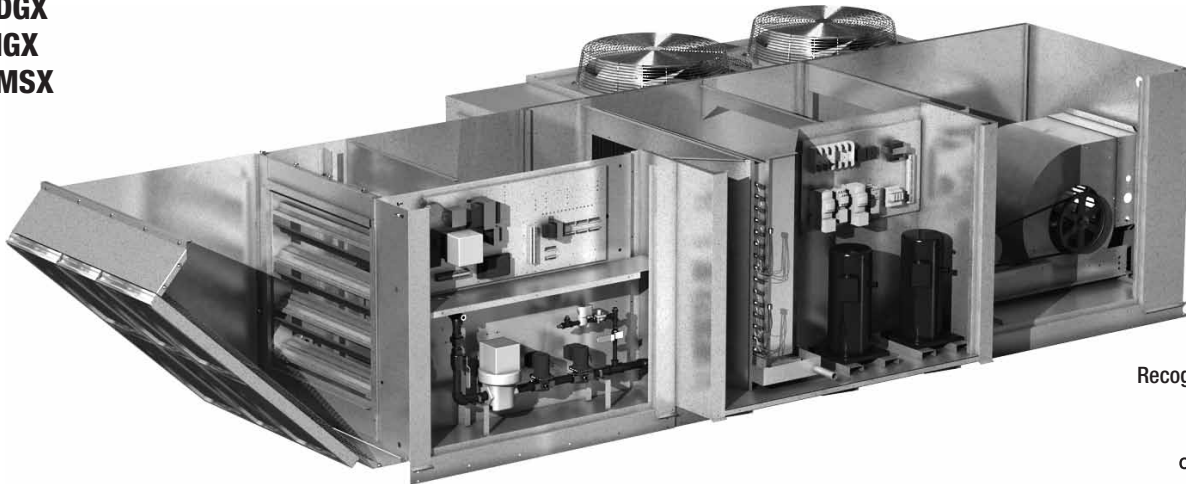

Recognized Component



## General Safety Information

Only qualified personnel should install and maintain this system. Personnel should have a clear understanding of these instructions and should be aware of general safety precautions. Improper installation can result in electric shock, possible injury due to coming in contact with moving parts, as well as other potential hazards. Other considerations may be required if high winds or seismic activity are present. If more information is needed, contact a licensed professional engineer before moving forward.

1. Follow all local electrical and safety codes, as well as the National Electrical Code (NEC), the National Fire Protection Agency (NFPA), where applicable. Follow the Canadian Electric Code (CEC) in Canada.
2. Unit must be securely and adequately grounded.
3. Verify that the power source is compatible with the equipment.
4. Never open access doors to the unit while it is running.

### DANGER

- Always disconnect power before working on or near this equipment. Lock and tag the disconnect switch or breaker to prevent accidental power up.
- If this unit is equipped with optional gas accessories, turn off gas supply whenever power is disconnected.

### CAUTION

This unit is equipped with a compressed refrigerant system. If a leak in the system should occur, immediately evacuate and ventilate the area. An EPA Certified Technician must be engaged to make repairs or corrections. Refrigerant leaks may also cause bodily harm.

### CAUTION

When servicing the unit, the internal components may be hot enough to cause pain or injury. Allow time for cooling before servicing.

## Receiving

This module is installed as a component of a make-up air unit and does not require any special handling. Refer to the Receiving portion of the unit Installation, Operation and Maintenance (IOM) Manual for complete instructions on receiving, unpacking and handling.

## Unpacking

The unit is shipped as a complete installed unit. Protective coverings have been installed on the face of the condenser coil that should be left in place until installation of the unit is complete. The only item that was shipped loose with the unit is the P Trap kit. Verify that the P Trap kit has been received. Refer to Unpacking instructions in unit IOM.

## Handling

Units are to be rigged and moved by the lifting brackets provided. Do not forklift. Refer to the Handling portion of the unit IOM for complete instructions on handling.

## Storage

Units are protected against damage during shipment. If the unit cannot be installed and operated immediately, precautions need to be taken to prevent deterioration of the unit during storage. The user assumes responsibility of the unit and accessories during storage. The manufacturer will not be responsible for damage during storage. The following suggestions are provided solely as a convenience to the user.

## Inspection and Maintenance During Storage

While in storage, inspect units once per month. Keep a record of inspection and maintenance performed. If moisture or dirt accumulations are found on the parts, the source should be located and eliminated. At each inspection, rotate all moving parts by hand ten to fifteen revolutions to distribute lubricant on motor and bearings. If paint deterioration begins, consideration should be given to touch-up or repainting. Units with special coatings may require special techniques for touch-up or repair.

Machined parts coated with rust preventative should be restored to good condition promptly if signs of rust occur. Immediately remove the original rust preventative coating with petroleum solvent and clean with lint-free cloths. Polish any remaining rust from the surface with crocus cloth or fine emery paper and oil. Do not destroy the continuity of the surfaces. Wipe clean thoroughly with Tectyl® 506 (Ashland, Inc.) or the equivalent. For hard to reach internal surfaces or for occasional use, consider using Tectyl® 511M Rust Preventative or WD-40® or the equivalent.

## Table of Contents

<b>General Safety Information</b> .....	1
<b>Receiving, Handling, Storage</b> .....	2
<b>Product Overview</b> .....	2
<b>Subassemblies</b> .....	3
Coils .....	3
Dampers .....	3
DX System .....	3
<b>Installation</b> .....	4
Service Clearances .....	4
Additional Clearances for Packaged DX Units .....	4
Lifting .....	4
Condensate Drain (P Trap) .....	4
Switch S4 .....	4
<b>Component Operation</b> .....	5
Compressor Components .....	5
Electrical Components .....	5
Refrigerant Components .....	5
Additional Control Components .....	5
<b>Factory Installed Refrigeration System</b> .....	6
Components .....	6
<b>Sequence of Operation</b> .....	7
Control Sequence .....	7
Optional Variable Air Volume .....	7
<b>Start-Up Unit</b> .....	8
Model and Serial Number .....	8
Pre-Start-Up Checklist .....	9
Special Tools Required .....	9
Voltage Imbalance .....	9
Start-Up Checklist .....	10
<b>Troubleshooting</b> .....	11-14
Refrigeration Circuit .....	11-14
<b>Routine Maintenance</b> .....	15
Monthly .....	15
Annually .....	15
Maintenance Procedures .....	15
<b>Reference</b> .....	15
Component Location .....	15
<b>Maintenance Log</b> .....	Backcover
<b>Warranty</b> .....	Backcover

## Product Overview

The Packaged DX Module for make-up air is a horizontally configured unit that is installed as a package in make-up air units and is designed for outdoor installations. The Packaged DX Module is used to temper the air that is supplied to the building. The make-up air unit is designed to provide sufficient air to replace air that is exhausted from the building and this module is designed to provide necessary cooling.

The DX system comes fully charged with R-410A refrigerant from the factory and is ready for operation upon arrival.

Units may be supplied with one or two compressors based on required cooling capacity. All units with multiple compressors allow for staging of compressors to meet a wider range of outdoor air loads while reducing the number of cycles per compressor.

### Compressed Refrigerant

All packaged DX modules are charged with environmentally friendly R-410A compressed refrigerant. Do not use tools or parts designed for other refrigerants on this unit.

### Safety Listing

Make-up air units are listed per ANSI/UL 1995, Heating and Cooling Equipment and are ETL Certified.

### Supplemental Installation, Operation and Maintenance Manuals

Refer to the Installation, Operation and Maintenance manual for the Make-Up Air unit for additional information.

### Models and Capacities

The Packaged DX Module for Make-Up Air Units is manufactured in three different platform sizes, each of which has several different output tonnage options. Examine shipping documents to verify correct model of the module as received.

Platform	Tonnage
H12	3, 5, 6, 8
H22	7, 9, 10
H32	10, 12, 16

### Model Number

A metal plate is located on the fixed panel access to the control center. The plate is marked with the Platform Type and Tonnage (for example, H12-6). Record the model number here:

---

## Subassemblies:

### Coils

Every module is supplied with a single DX evaporator coil. If there is only one cooling circuit, then the DX coil is not divided. If two cooling circuits are specified, then the DX coil will be a split-face. A single condenser coil is attached to the exterior of the module. If more than one cooling circuit is present, that condenser coil will be of split-face configuration.

### Dampers

Only an inlet damper may be installed in a PDX module and it will only be found when the module is installed in either model IGX or MSX that was not ordered with an inlet damper module.

### DX System

The DX system in the module is a complete, sealed unit with compressed R-410A refrigerant. It consists of one or two compressors, evaporator and condenser coils and the following integral components:

- expansion valves
- liquid line filter-drier
- service / charging valves
- moisture indicating sight glass
- crankcase heater on each compressor

Each DX system incorporates the following:

- high pressure manual reset cutout
- low pressure auto-reset cutout

# Installation

## Service Clearances

All make-up air units require minimum clearances on all sides for routine maintenance. Filter replacement, drain pan inspection and cleaning, fan bearing lubrication and belt adjustment are all examples of routine maintenance that must be performed. Blower and motor assemblies and coil and filter sections are always provided with a service door or panel for proper component access. Clearances for component removal may be greater than the service clearances. Refer to submittal drawings for these clearance dimensions. See also Page 4 of this manual.

## Additional Clearances for Packaged DX Units

Packaged DX units require additional service clearance because they must have unrestricted air movement around the condenser coil and condenser fans. Hot air is being discharged from the condenser fans during operation and the more clearance available, the better the chance of avoiding recirculation or coil starvation. This unit should never be placed under an overhang or inside a building. A minimum of 48 inches above the condenser fans is recommended.

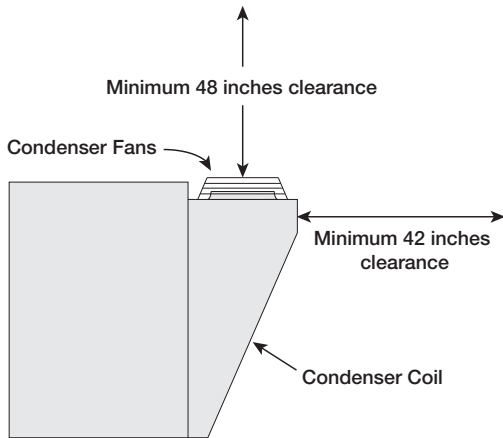

End view of make-up air unit with Packaged DX

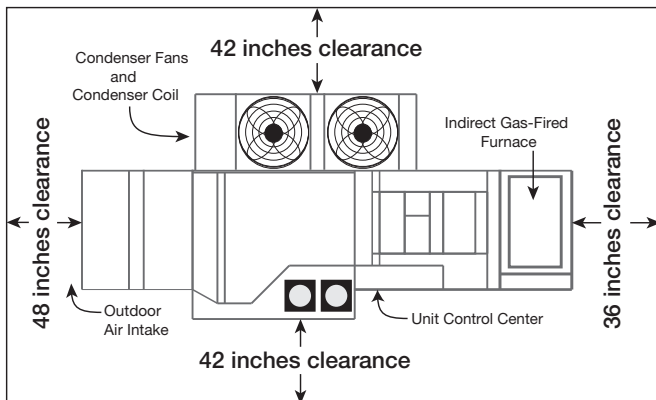

## Lifting

All units equipped with this module are provided with either four or six lifting lugs. When the unit is being hoisted, all of the provided lugs must be used for support. Four lifting lugs are on the four corners of the unit, located at the base. In addition, there may be two more lifting lugs located at the top of the unit. The locations of those two top lugs varies somewhat from unit to unit.

Use spreader bars as shown to prevent damage to the cabinet. If top-mounted lifting lugs are present, they must be used in conjunction with the bottom-mounted lifting lugs when hoisting the unit.

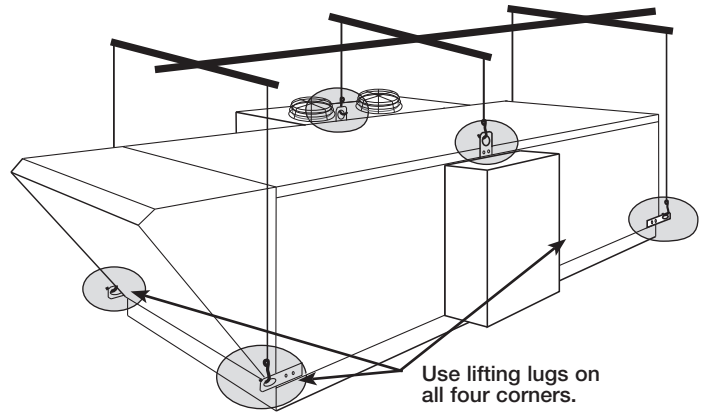

Lifting Details

## Install Condensate Drain (P Trap)

The only installation step that is specific to the DX module is installation and priming of the engineered P trap. Locate the P trap kit that was shipped with the unit and install the kit in accordance with the enclosed instructions.



## Provide and Install Switch S4

Each Packaged DX unit requires an On/Off switch to enable the unit to run. This is a user-supplied switch that may be a toggle switch mounted in a 2 x 4 inch electric box (mounted in a position chosen by the user), or it may be a simple jumper or even a control switch installed in a remote control panel supplied by the factory. See also "Additional Control Components" on page 5 of this manual.

## Component Operation

### Compressor Components

Each Packaged DX module has a complete set of compressor contactors, condenser fan contactors, relays and certain integral safety controls located in the module.

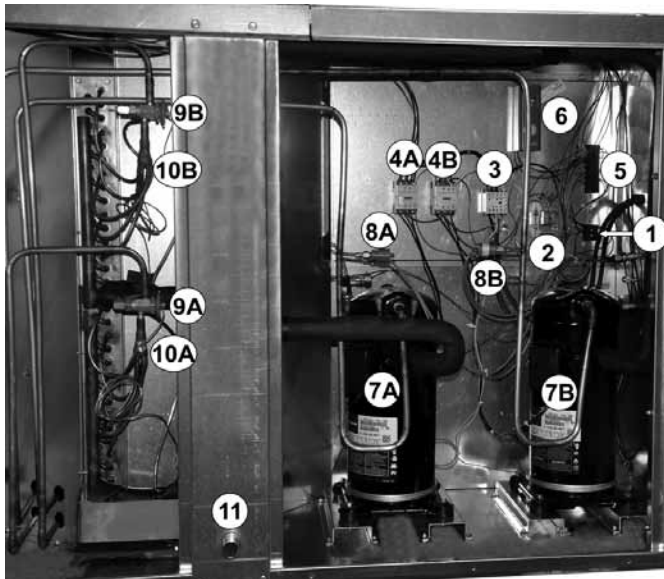

Typical Packaged DX Compressor Compartment

### Electrical Components

1. High Voltage Terminal Strip
2. Compressor Relays
3. Condenser Fan Contactor
- 4A. Compressor Contactor (Circuit A)
- 4B. Compressor Contactor (Circuit B)
5. Low Voltage Terminal Strip
6. High Limit Safety Control – Direct Gas-Fired units only

### Refrigeration Components

- 7A. Compressor (Circuit A)
- 7B. Compressor (Circuit B)
- 8A. High Pressure Sensor (Circuit A, Manual Reset)
- 8B. High Pressure Sensor (Circuit B, Manual Reset)
- 9A. Thermostatic Expansion Valve (TXV) (Circuit A)
- 9B. Thermostatic Expansion Valve (TXV) (Circuit B)
- 10A. Refrigerant Distributor (Circuit A)
- 10B. Refrigerant Distributor (Circuit B)
11. Condensate Drain (P trap here)

### Additional Control Components

In addition to the control components located in the PDX module, various high- and low-voltage circuits are found in the Make-Up Air Unit control center. See the unit-specific wiring diagram (found in the unit control center) for complete information.

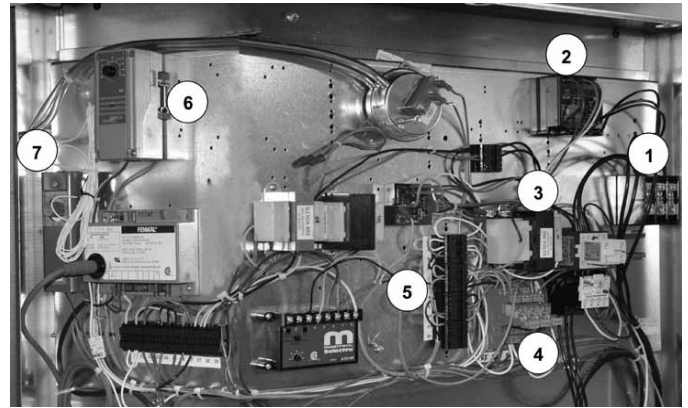

Typical Unit Control Center

1. **Power Distribution Block** - field-supplied power from main disconnect switch is terminated here.
2. **Phase Monitor** has jumpers going to power distribution block)
3. **Transformer** provides 24 VAC to various low voltage devices including the Phase Monitor and to Low Voltage Terminal Strip in compressor compartment.
4. **Relays RC1 and RC2** are wired to the control center in the compressor compartment.
5. **Low Voltage Terminal Strip** - Switch S4 terminates here.
6. **Thermostat TS5** monitors outdoor air temperature and turns the DX unit on or off.
7. **Inlet Air Sensor** monitors the incoming air temperature and will disable the DX unit if ambient temperatures are too low.



**Phase Monitor** constantly checks for loss of a phase, phase unbalance or phase reversal. It requires 24 VAC to operate. When a fault is detected, it cuts off the power supply to the low voltage terminal strip, disabling all motors. It has two LED indicator lights, showing “on” and “fault”.

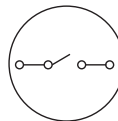

**Switch S4** (not shown) is terminated on Low Voltage Terminal Strip 5 above. S4 is field-supplied and field-installed unless ordered from the factory. See the unit specific wiring diagram.



**Thermostat TS5** monitors outdoor air temperature. It is field-adjustable. If there is more than one cooling circuit, an additional controller for the second stage will be provided.

# Factory Installed Refrigeration System Components

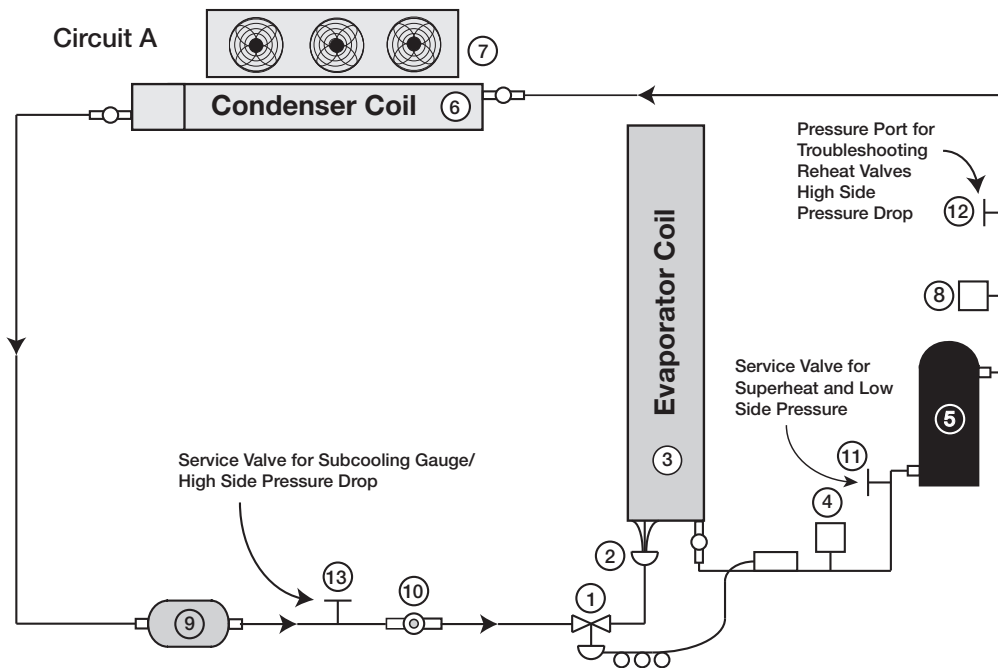

## 1. Thermostatic Expansion Valve (TXV)

Each unit is equipped with a Thermal Expansion Valve on each refrigerant circuit. The valve controls the flow of liquid refrigerant entering the evaporator coil by maintaining a constant, factory set superheat of 10°F. The valve is adjustable and is located on the side of the evaporator coil and can be accessed through the coil panel access door.

## 2. Refrigerant Distributor

Attached to the TXV is a refrigerant distributor. The refrigerant distributor evenly distributes the refrigerant to each circuit of the evaporator coil to provide optimum performance.

## 3. Evaporator Coil

The coil is located in the supply airstream. In the DX system, the liquid refrigerant is expanded in the TXV and it then flows through the evaporator coil. The refrigerant enters the coil as a low temperature liquid/gas where it eventually boils into a low temperature, low pressure gas prior to going into the compressor. As the refrigerant passes through the evaporator coil, it absorbs heat from the airstream. To ensure proper operation, the coil surface must be cleaned so that air movement over the coil provides the necessary heat transfer.

## 4. Low Limit Pressure Switch

The switch is installed in the suction line and disables the DX system with the suction pressure drops below the set point. The switch will auto-reset when the pressure rises above the auto-reset set point.

## 5. Compressors

## 6. Condensing Coil

## 7. Condenser Fans

## 8. High Limit Pressure Switch

The switch opens when refrigerant pressure increases above the set point in the liquid line and it then requires a manual reset.

## 9. Liquid Line Filter-Drier

The liquid line filter-drier prevents moisture and foreign matter from entering the expansion valve.

## 10. Moisture Indicating Sight Glass

During normal operating conditions, the sight glass should typically be liquid. Some gas is acceptable, but excessive bubbles may indicate improper charge or a leak in the system. A green dot indicates the moisture level in the refrigerant, while a yellow dot indicates moisture in the system and needs to be dealt with.

## 11-13. Access Ports

## Sequence of Operation

The compressors are energized by an outdoor air thermostat TS5, located in the unit control center. The thermostat sensor is located in the intake airstream upstream of the DX coil. The thermostat can be a single or dual stage thermostat depending on the number of compressors. The first stage of cooling will energize when the outdoor air temperature rises above the thermostat set point plus the differential. The thermostat is factory set at 80°F with a differential of 5°F but can be field adjusted. The second stage of cooling will energize when the outdoor air temperature rises above the second stage offset plus the differential. The second stage offset is factory set at 10°F and the second stage differential is set at 5°F. See the chart below for a graphical representation of the control operation.

To summarize the cooling controls, the first stage of cooling will turn on at 85°F and the second stage of cooling will turn on at 95°F. The second stage of cooling will turn off at 90°F and the first stage of cooling will turn off at 80°F.

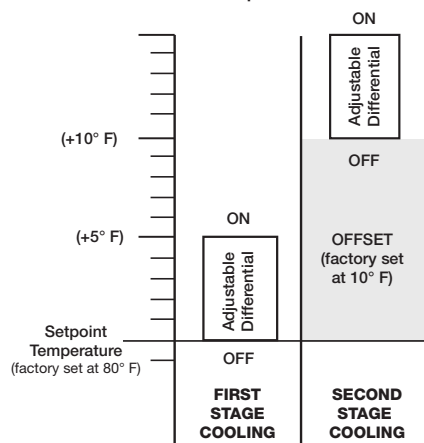

## Control Sequence

1. Fan switch needs to be closed (S3) between terminals R and G.
2. Heating/Cooling switch (S4) is closed between terminal R and Y1.
3. N.O. contact on fan relay (RF) is energized and closed.
4. When the outdoor air temperature is above the set point plus the differential power passes through N.O. contacts on outdoor air thermostat (TS5) and energizes the cooling relay (RC1).
5. When the pressure switches LPS (refrigerant low pressure switch) and HPS (refrigerant high pressure switch) are in their normal state relay R10 will energize. Starting the first stage compressor contactor.
6. When the outdoor air temperature is above the second stage offset plus the differential power passes through N.O. contacts on outdoor air thermostat (TS5) and energizes the cooling relay (RC2).
7. When the pressure switches LPS and HPS (refrigerant high pressure switch) are in their normal state relay R11 will energize, starting the second stage compressor contactor.

## Control Sequence - Variable Air Volume (optional)

1. Fan switch needs to be closed (S3) between terminals R and G.
2. Heating/Cooling switch (S4) is closed between terminal R and Y1.
3. N.O. contact on fan relay (RF) is energized and closed.
4. When the outdoor air temperature is above the set point plus the differential power passes through N.O. contacts on outdoor air thermostat (TS5) and energizes the cooling relay (RC1).
5. When the pressure switches LPS (refrigerant low pressure switch) and HPS (refrigerant high pressure switch) are in their normal state relay R10 will energize. Starting the first stage compressor contactor.
6. When the outdoor air temperature is above the second stage offset plus the differential power passes through N.O. contacts on outdoor air thermostat (TS5) and energizes the cooling relay (RC2).
7. When the pressure switches LPS and HPS (refrigerant high pressure switch) are in their normal state relay R11 will energize, starting the second stage compressor contactor.
8. When the discharge air temperature drops below the low temperature set point (TS9) factory set at 55°F, the second stage compressor contactor will de-energize, turning off the second stage compressor.
9. The second stage compressor will re-energize when the discharge air temperature rises above 75°F.

# Start-Up Unit

## DANGER

Electric shock hazard. Can cause injury or death. Before attempting to perform any service or maintenance, turn the electrical power to unit to OFF at disconnect switch(es). Unit may have multiple power supplies.

## CAUTION

Use caution when removing access panels or other unit components, especially while standing on a ladder or other potentially unsteady base. Access panels and unit components can be heavy and serious injury may occur.

## CAUTION

Do not operate without the filters and birdscreens installed. They prevent the entry of foreign objects such as leaves, birds, etc.

## CAUTION

Do not run unit during construction phase. Damage to internal components may result and void warranty.

## WARNING

- Unit was factory tested. All blowers, fans, and compressors are set-up to run correctly when supplied power. If any one fan is running backwards or the compressor is making loud noises, immediately turn off the power. Switch two leads on the incoming power to the disconnect. This will ensure proper operation of the unit. Failure to comply may damage the compressors and void the warranty.
- Do not jumper any safety devices when operating the unit. This may damage components within or cause serious injury or death.
- Do not operate compressor when the outdoor temperature is below 40°F.
- Do not short-cycle the compressor. Allow 5 minutes between “on” cycles to prevent compressor damage.
- DX system is charged with refrigerant. Start-up must be performed by EPA Certified Technician.

## WARNING

Prior to starting up the unit, power must be energized for 24 hours without a call for cool to allow the compressor crankcase heaters time to boil off any liquid refrigerant present in the compressor.

Every installation requires a comprehensive start-up to ensure proper operation of the unit. As part of that process, the following checklist must be completed and information recorded. Starting up the unit in accordance with this checklist will not only ensure proper operation, but will also provide valuable information to personnel performing future maintenance. Should an issue arise which requires factory assistance, this completed document will allow unit experts to provide quicker resolve. Qualified personnel should perform start-up to ensure safe and proper practices are followed.

Unit Model No. \_\_\_\_\_

Unit Serial No. \_\_\_\_\_

Compressor 1 Model No. \_\_\_\_\_

Compressor 2 Model No. \_\_\_\_\_

Start-Up Date \_\_\_\_\_

Start-Up Personnel Name \_\_\_\_\_

Start-Up Company \_\_\_\_\_

Phone Number \_\_\_\_\_



## Pre-Start-Up Checklist

- Disconnect and lock-out all power switches.
- Remove any foreign objects that are located in the unit.
- Check all fasteners, set-screws, and locking collars on the fans, bearings, drives, motor bases and accessories for tightness.
- Rotate the fan wheels by hand and ensure no parts are rubbing.
- Filters can load up with dirt during building construction. Replace any dirty pleated filters and clean the aluminum mesh filters in the intake hood.
- Verify that non-motorized dampers open and close properly.
- Check the tightness of all factory wiring connections.
- Verify control wire gauge.
- Verify proper drain trap installation.
- Check condensing fans for any damage or misalignment. Spin the blades and make sure they don't contact any parts and are free turning without any resistance.
- Look over the piping system.
- Inspect all coils within the unit. Fins may get damaged in transit or during construction. Carefully straighten fins with a fin comb.
- If there is an indirect gas-fired furnace in this unit, refer to the manual provided with this unit for Pre-Start-Up information.
- This unit contains a crankcase heater for each compressor which needs power supplied to it 24 hours prior to start-up. If start-up is scheduled in 24 hours, unlock the disconnect power and energize unit.

## SPECIAL TOOLS REQUIRED

- Voltage Meter (with wire probes)
- Amperage Meter
- Pressure Gauges – (refrigerant)
- Tachometer
- Thermometer
- Incline manometer or equivalent

## Start- Up Procedure

The unit will be in operational mode during start-up. Use necessary precautions to avoid injury. All data must be collected while the unit is running.

- Make sure Pre-Start-Up checklist is complete.
- Jumper R to G, R to Y1, and R to Y2 (if applicable) on the control board.
- Turn the disconnect on. After 3 minutes compressors will come on. Make sure all fans and compressors are rotating the correct direction.
- Allow the unit to run until the refrigerant system stabilizes. Approximately 5-10 minutes.

## Voltage Imbalance

In a 3-phase system, excessive voltage imbalance between phases will cause motors to overheat and eventually fail. Maximum allowable imbalance is 2%. To determine voltage imbalance, use recorded voltage measurements in this formula.

Key:  $V1, V2, V3$  = line voltages as measured  
 $VA$  (average) =  $(V1 + V2 + V3) / 3$   
 $VD$  = Line voltage ( $V1, V2$  or  $V3$ ) that deviates farthest from average ( $VA$ )

Formula:  $\% \text{ Voltage Imbalance} = [100 \times (VA - VD)] / VA$

# Start-Up Checklist

Line Voltage. Check at unit disconnect.

L1-L2 \_\_\_\_\_ Volts      L2-L3 \_\_\_\_\_ Volts      L1-L3 \_\_\_\_\_ Volts

## Condensing Fans

Condensing Fan 1	L1	_____ Amps	L2	_____ Amps	L3	_____ Amps
Condensing Fan 2	L1	_____ Amps	L2	_____ Amps	L3	_____ Amps
Condensing Fan 3	L1	_____ Amps	L2	_____ Amps	L3	_____ Amps

## Compressors

Outdoor Air Temperature	_____ Deg F	Outdoor Air Relative Humidity	_____ % RH
Return Air Temperature	_____ Deg F	Return Air Relative Humidity	_____ % RH

### Compressor 1:

\_\_\_\_\_ L1 amps  
 \_\_\_\_\_ L2 amps  
 \_\_\_\_\_ L3 amps  
 \_\_\_\_\_ Crankcase Heater

### Compressor 2:

\_\_\_\_\_ L1 amps  
 \_\_\_\_\_ L2 amps  
 \_\_\_\_\_ L3 amps  
 \_\_\_\_\_ Crankcase Heater

**Superheat** \_\_\_\_\_ Deg. F.  
*Should be between 8° and 12°F.*

**Superheat** \_\_\_\_\_ Deg. F.  
*Should be between 8° and 12°F.*

**Subcooling** \_\_\_\_\_ Deg. F.  
*Should be between 12° and 17°F.*

**Subcooling** \_\_\_\_\_ Deg. F.  
*Should be between 12° and 17°F.*

**Discharge Pressure** \_\_\_\_\_ PSIG  
*Should be between 300 and 500 PSIG*

**Discharge Pressure** \_\_\_\_\_ PSIG  
*Should be between 300 and 500 PSIG*

**Suction Line Pressure** \_\_\_\_\_ PSIG  
*Should be between 100 and 135 PSIG*

**Suction Line Pressure** \_\_\_\_\_ PSIG  
*Should be between 100 and 135 PSIG*

**Liquid Line Temperature** \_\_\_\_\_ Deg. F.

**Liquid Line Temperature** \_\_\_\_\_ Deg. F.

**Suction Line Temperature** \_\_\_\_\_ Deg. F.

**Suction Line Temperature** \_\_\_\_\_ Deg. F.

**Moisture Indicating Sight Glass**  
 Liquid Visible Yes / No  
 Color of Center Dot **Green / Yellow**

**Moisture Indicating Sight Glass**  
 Liquid Visible Yes / No  
 Color of Center Dot **Green / Yellow**

**Hot Gas Bypass Operational** **Yes / No**

**Hot Gas Bypass Operational** **Yes / No**



## Troubleshooting – Refrigeration Circuit

### TROUBLESHOOTING NOTE

Before any components are changed on the refrigeration system, the cause of the failure must be determined. Further problems will exist unless the true cause or problem is identified and corrected.

### IMPORTANT

Do not release refrigerant to the atmosphere! If required service procedures include the adding or removing of refrigerant, the service technician must comply with all federal, state and local laws. The procedures discussed in this manual should only be performed by a qualified EPA Certified Technician.

**NOTE:** Unit is equipped with a phase loss/phase reversal control. If system does not start, check phase of electrical supply.

The first step is to check airflow conditions. (e.g. improper ductwork, atypical wet bulb / dry bulb, etc.) After these steps have been eliminated, proceed with troubleshooting by following this guide:

Symptom	Possible Cause	Corrective Action
Compressor will not run or does not start	Open disconnect switch or circuit breaker.	Close switch and/or breaker.
	Compressor contactor not closing.	Check voltage to contactor coil, transformer, slave relay, system. Replace parts as necessary.
	Blown fuse or tripped breaker.	Check for shorted wire or motor. Replace fuse after correcting problem.
	Low line voltage.	Check line voltage. If more than 10% from compressor marking, correcting is necessary.
	Compressor motor protector open.	Motor thermal protector automatically resets. Allow time (2 hours) for compressor to cool down so protector will reset. Restart and check for reason overheat occurred.
	Compressor defective.	Check motor for open circuit, short circuit, grounded windings, or burn out. Compressor may be seized; check refrigerant. If necessary, replace compressor.
	High pressure switch open or defective.	If manual reset (high pressure), reset switch. (Switch opens at 600 psi and will not reset above 420 psi for R-410A). Replace if defective.
	Low pressure switch open or defective.	Switch will open at 50 psi and auto-close at 90 psi. Replace if defective.
	Open room thermostat or control. (No cooling required).	Check room temperature. If temperature is proper, wait for thermostat to close.
Loose wiring.	Check all wire terminals and tighten as necessary.	
Compressor starts but cuts out on low pressure  <i>Low pressure switch activates at 50 PSIG</i>	Low or loss of refrigerant charge.	Check refrigerant pressures and temperatures (subcooling.)
	Airflow restricted.	Check for dirty evaporator coil, dirty filters, dampers closed, iced evaporator coil, improper belt, check motor amps, check duct design.
	Restriction in refrigerant line.	Check refrigerant pressures, look for frosted tubing and components indicating a restriction. Check pressure drop across the filter drier.
	Defective low pressure switch.	Replace.

Always have a completed Pre-Start-Up Checklist and Start-Up Checklist prior to requesting parts or service information.

## Troubleshooting – Refrigeration Circuit *(continued)*

Symptom	Possible Cause	Corrective Action
Compressor starts but cuts out on high pressure switch  <i>High pressure activates at 600 PSIG</i>	Refrigerant overcharge.	Check pressures, charge by subcooling.
	Condenser fan motor defective.	Check fan motor.
	Condenser coil inlet obstructed or dirty.	Check coil and clearances. Clean coil if necessary.
	Air or non-condensables in system.	Check high side equalized pressures, check thermal expansion valves.
	Defective high pressure switch.	Replace.
	Restriction in discharge or liquid line.	Check refrigerant line pressures, check thermal expansion valves, replace any defective component.
	Condensing fan relay not pulling in.	Replace.
Compressor cuts out on thermal overload	Low voltage.	Check voltage.
	Sustained high discharge pressure.	Check running amperage and conditions described under “low suction pressure” symptoms.
	High suction and discharge pressures.	Check thermal expansion valve setting, check for air in system. Check air conditions and cfm.
	Defective compressor overload.	If compressor is hot, allow compressor to cool for two hours. Recheck for open circuit.
	Improper refrigerant charge.	Check subcooling.
	Improperly wired.	Review wiring schematics.
	Loose wiring.	Check all connections.
	Defective start relay.	Replace relay.
Motor windings damaged.	Verify amp draw.	
Compressor hums, but will not start	Improperly wired.	Review wiring schematics.
	Low line voltage.	Check voltage.
	Loose wiring.	Check all connections.
	Defective start relay.	Replace relay.
	Motor winding damaged.	Verify amp draws. Replace compressor if necessary.
	Internal compressor mechanical damage.	Replace.
Compressor noisy or vibrating	Refrigerant overcharge.	Check pressures and subcooling.
	Liquid floodback.	Check thermal expansion valve setting. Check for refrigerant overcharge.
	Tubing rattle.	Dampen tubing vibration by taping or clamping. Carefully bend tubing away from contact where possible.
	Scroll compressor rotating in reverse. (3-phase)	Check high and low side pressures during operation to confirm. Rewire for opposite rotation.
	Damaged compressor.	Replace the compressor.
	Improper mounting on unit base.	Check that compressor is properly isolated and mounting bolts are tight.

*Always have a completed Pre-Start-Up Checklist and Start-Up Checklist prior to requesting parts or service information.*

## Troubleshooting – Refrigeration Circuit *(continued)*

Symptom	Possible Cause	Corrective Action
High suction pressure	Excessive load on evaporator coil.	Check for high entering wet bulb temperature, check for excessive air flow.
	Expansion valve sensing bulb not secured to suction line.	Check the thermal expansion valve, ensure bulb is insulated. Check superheat. If superheat is high, then valve is choking refrigerant flow. <ul style="list-style-type: none"> <li>• Check bulb for contact.</li> <li>• Adjust valve for superheat ~10°F.</li> <li>• Replace valve power head or valve.</li> </ul>
	Thermostatic expansion valve. Overfeeding.	Check bulb location and clamping. Adjust superheat. Replace expansion valve power head.
	Overcharged.	Check pressures and subcooling.
High discharge pressure	Thermal expansion valve setting.	Check thermal expansion setting and calibrate superheat / subcooling.
	Air inlet to condenser dirty or obstructed.	Check for proper clearances and possible air recirculating. Clean coil.
	Condenser fan motor defective.	Check condenser fan motor.
	Too much refrigerant.	Check subcooling. Remove excess refrigerant.
	Non-condensable in system.	Remove non-condensable from system.
	Dirty condenser coil.	Clean condenser coil.
	Condenser fan not running or running backwards.	Check electrical circuit and fuse. Check fan cycling controls.
	High load conditions.	Add more equipment or reduce load.
Low suction pressure	Refrigerant undercharge/loss of refrigerant charge.	Check pressures and subcooling.
	Blower running backward.	Confirm blower rotation. If reversed, interchange any two wires from 3-phase disconnect.
	Loose blower, pulley or belts.	Check drive pulley alignment, belt tension.
	Low entering air temperature. (Low load conditions).	Check entering air wet bulb conditions.
	Refrigerant leak.	Check system for leaks. Repair leaks and add refrigerant.
	Evaporator dirty or iced-up, or airflow restricted.	Clean the coil. Check fan operation. Check airflow.
	Plugged liquid line filter-drier.	Replace filter-drier, check psi across filter.
	Improper hot gas bypass setting.	Check setting and correct as required.
	Expansion valve defective, superheat too high or valve too small.	Adjust valve for proper superheat or replace the expansion valve if too small or defective.
	Moisture in system, check sight glass.	Reclaim refrigerant, check for leaks, recharge.

*Always have a completed Pre-Start-Up Checklist and Start-Up Checklist prior to requesting parts or service information.*

Symptom	Possible Cause	Corrective Action
Low discharge pressure	Insufficient refrigerant charge.	Check subcooling, check for leak. Repair leak and add refrigerant.
	Defective or improperly adjusted expansion valve.	Check superheating and adjust thermal expansion valve.
	Low suction pressure.	See “low suction pressure”.
	Faulty condenser temperature controls. (Condensing fan cycle switch).	Check condenser controls and reset to obtain desired condensing temperature.
Compressor short cycles	Thermostat location or controls malfunction.	Check thermostat, check heat anticipator setting.
	Improper refrigerant charge.	Check subcooling, verify superheat.
	Defective high or low pressure control.	Check high or low pressure switch.
	Poor air distribution.	Check ductwork for recirculating.
	High discharge pressure.	See “high discharge pressure”.
	Low airflow at evaporator(s).	Check blower operation and airstream restrictions.
	Incorrect unit selection (oversized).	Contact factory.
Compressor loses oil	Refrigerant leak.	Check system for leaks. Repair leaks and add refrigerant.
	Short cycling.	Check low pressure control settings.
	Refrigerant flood back.	Check thermal expansion valve setting. Check for refrigerant overcharge. Check crankcase heater operation.
	Reheat flush cycle inadequate.	Contact factory.
Not enough cooling or lack of cooling	Refrigeration undercharged.	Check subcooling. Adjust charge, if necessary.
	Dirty filter or evaporator coil.	Check filter, coil and airflow.
	Dirty or clogged condenser coil.	Check coil and airflow.
	Air or other non-condensables in system.	Check equalized high side pressure with equivalent outdoor temperature.
	Restriction in suction and liquid line.	Check for restrictions in refrigerant circuit.
	Control contacts stuck.	Check wiring.
Liquid line is frosted or wet	Excessive load.	Add more equipment or reduce room load.
	Restriction in liquid line.	Clear restriction upstream of point of frosting.
Suction line is frosting	Insufficient evaporator airflow.	Check airflow, check filters, check drive for loose parts or belts. Check VFD control signal for proper operation.
	Malfunctioning or defective expansion valve.	Check bulb of thermal expansion valve.
Frost on evaporator coil	Hot gas bypass valve not functioning properly.	Check valve. If defective, replace.
	Manual hot gas bypass valve closed.	Open valve.
	Low load or airflow.	Increase airflow, check filters.

*Always have a completed Pre-Start-Up Checklist and Start-Up Checklist prior to requesting parts or service information.*

## Routine Maintenance

### DANGER

Electric shock hazard. Can cause injury or death. Before attempting to perform any service or maintenance, turn the electrical power to the unit to OFF at disconnect switch(es). Unit may have multiple power supplies.

### CAUTION

Use caution when removing access panels or other unit components, especially while standing on a ladder or other potentially unsteady base. Access panels and unit components can be heavy and serious injury may occur.

This unit requires minimal maintenance to operate properly. To ensure proper operation and longevity, the following maintenance schedule should be followed. The items in this list assume a relatively clean air environment and may require attention more frequently in a dusty or dirty area. If this unit contains an indirect gas-fired heater, refer to the Installation, Operation and Maintenance manual provided with the unit for maintenance purposes. An EPA Certified Technician should complete all refrigeration systems checks.

## Maintenance Frequency:

### Monthly

1. Condensate Drain  
Inspect and clean. Refill with water or glycol.

### Annually

It is recommended that the annual inspection and maintenance occur at the start of the cooling season. After completing the checklist, follow the unit start-up checklist provided in the manual to ensure the refrigeration system operates in the intended manner.

1. Door Seal  
Check if intact and pliable.
2. Wiring Connections  
Check all connections for tightness.
3. Cabinet  
Check entire cabinet, inside and out, for dirt build-up or corrosion. Remove accumulated dirt, remove any surface corrosion and coat the area with appropriate finish.
4. Evaporator Coil Maintenance  
Check for cleanliness. Clean if required.
5. Condenser Coil Maintenance  
Check for cleanliness. Clean if required.
6. Condensate Drain  
Inspect and clean. Refill with water.
7. Condensing Fan Blades and Motors  
Check for cleanliness.  
Check all fasteners for tightness.  
Check for fatigue, corrosion and wear.

## Maintenance Procedures:

### Lubrication

Check all moving components for proper lubrication. Apply lubricant where required. Any components showing excessive wear should be replaced to maintain the integrity of the unit and ensure proper operation.

### Dampers

Check damper (if present) to ensure it opens and closes properly and without binding. Apply power to motorized dampers to ensure the actuator opens and closes the damper as designed.

## Reference - component location

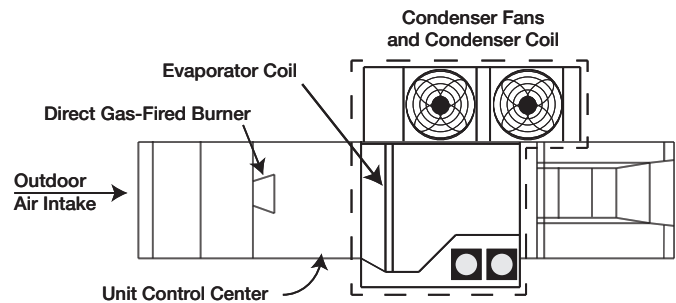

Model DGX Make-Up Air Unit

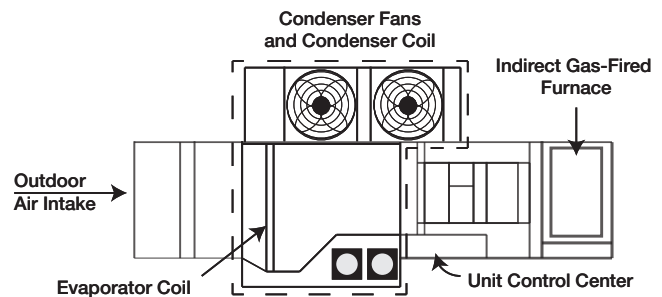

Model IGX Make-Up Air Unit

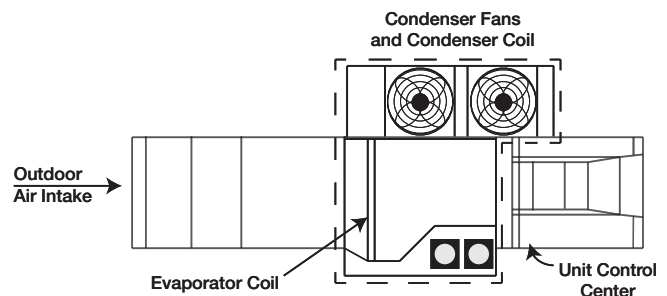

Model MSX Make-Up Air Unit  
with Electric Heat

# Maintenance Log

Date \_\_\_\_\_ Time \_\_\_\_\_ AM/PM  
Notes: \_\_\_\_\_

\_\_\_\_\_  
\_\_\_\_\_  
\_\_\_\_\_

Date \_\_\_\_\_ Time \_\_\_\_\_ AM/PM  
Notes: \_\_\_\_\_

\_\_\_\_\_  
\_\_\_\_\_  
\_\_\_\_\_

Date \_\_\_\_\_ Time \_\_\_\_\_ AM/PM  
Notes: \_\_\_\_\_

\_\_\_\_\_  
\_\_\_\_\_  
\_\_\_\_\_

Date \_\_\_\_\_ Time \_\_\_\_\_ AM/PM  
Notes: \_\_\_\_\_

\_\_\_\_\_  
\_\_\_\_\_  
\_\_\_\_\_

Date \_\_\_\_\_ Time \_\_\_\_\_ AM/PM  
Notes: \_\_\_\_\_

\_\_\_\_\_  
\_\_\_\_\_  
\_\_\_\_\_

Date \_\_\_\_\_ Time \_\_\_\_\_ AM/PM  
Notes: \_\_\_\_\_

\_\_\_\_\_  
\_\_\_\_\_  
\_\_\_\_\_

Date \_\_\_\_\_ Time \_\_\_\_\_ AM/PM  
Notes: \_\_\_\_\_

\_\_\_\_\_  
\_\_\_\_\_  
\_\_\_\_\_

Date \_\_\_\_\_ Time \_\_\_\_\_ AM/PM  
Notes: \_\_\_\_\_

\_\_\_\_\_  
\_\_\_\_\_  
\_\_\_\_\_

# Warranty

Greenheck warrants this equipment to be free from defects in material and workmanship for a period of one year from the shipment date. Any units or parts which prove to be defective during the warranty period will be replaced at our option when returned to our factory, transportation prepaid. Motors are warranted by the motor manufacturer for a period of one year. Should motors furnished by Greenheck prove defective during this period, they should be returned to the nearest authorized motor service station. Greenheck will not be responsible for any removal or installation costs.

*As a result of our commitment to continuous improvement, Greenheck reserves the right to change specifications without notice.*

AMCA Publication 410-96, Safety Practices for Users and Installers of Industrial and Commercial Fans, provides additional safety information. This publication can be obtained from AMCA International, Inc. at [www.amca.org](http://www.amca.org).



Phone: (715) 359-6171 • Fax: (715) 355-2399 • E-mail: [gfcinfo@greenheck.com](mailto:gfcinfo@greenheck.com) • Website: [www.greenheck.com](http://www.greenheck.com)