

Installation, Operation and Maintenance Manual

Please read and save these instructions for future reference. Read carefully before attempting to assemble, install, operate or maintain the product described. Protect yourself and others by observing all safety information. Failure to comply with instructions could result in personal injury and/or property damage!

**Model SWB
Series 300**

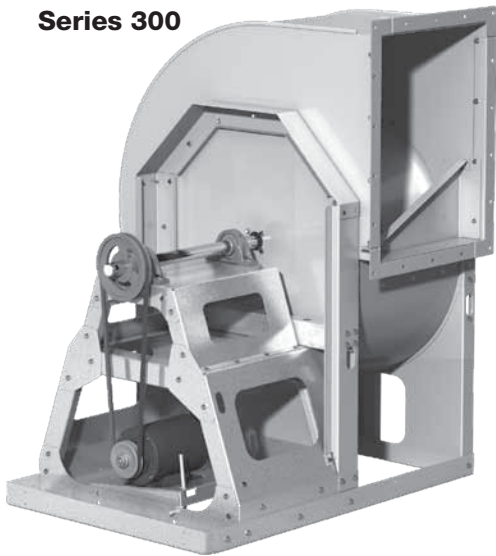

**Model SWB
Series 200**

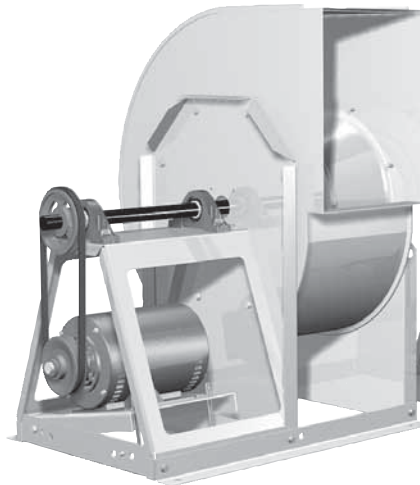

**Model SWB
Series 100**

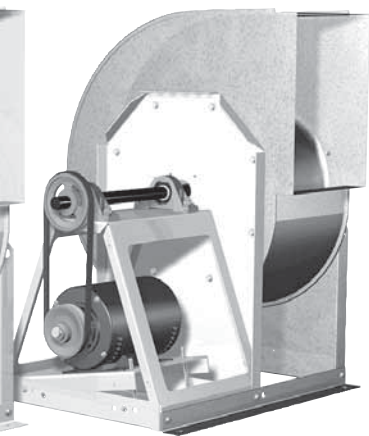

Model SFB

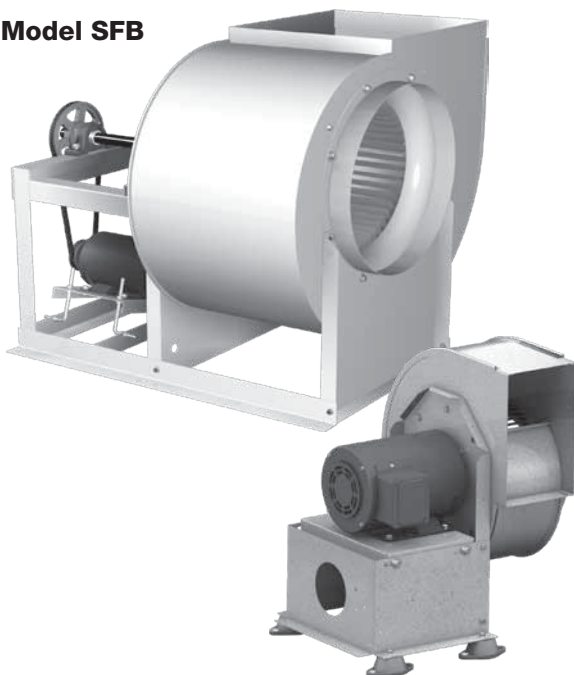

Model SFD

Table of Contents

Motor and Drive Installation (Units Shipped from Stock)	2
Installation	3
Affect of Installation on Performance	3
UL/cUL 762 - Restaurant Exhaust	4
Pre-Starting Checks	4-5
Belt Drive Fan Maintenance	6
Bearing Lubrication Schedule	6
Motor Maintenance (Belt and Direct Drive)	6
Parts List	7
Troubleshooting Chart	8

Motor and Drive Installation Instructions

Model SWB units are shipped from stock without motors or drives.



1. Adjust motor pulley to its closed position for maximum fan speed or increments of 1/2 turn open (maximum of 5 turns open) for reduced fan speed. Tighten set screw on flat area only.

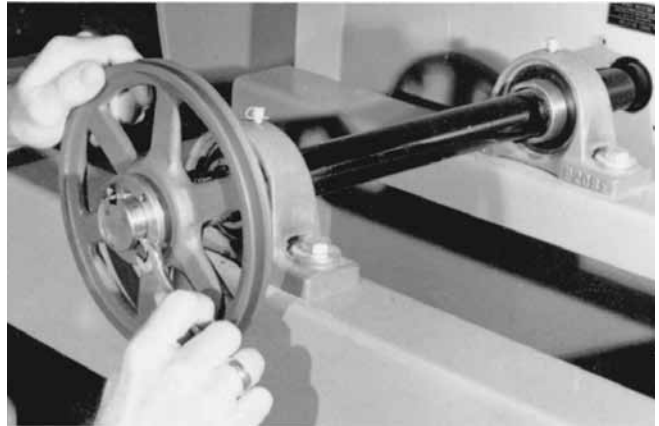

4. Install shaft pulley to fan shaft.



2. Install motor pulley to the motor shaft and install motor to the motor plate. Pre-punched holes are provided for most common motor frame sizes.

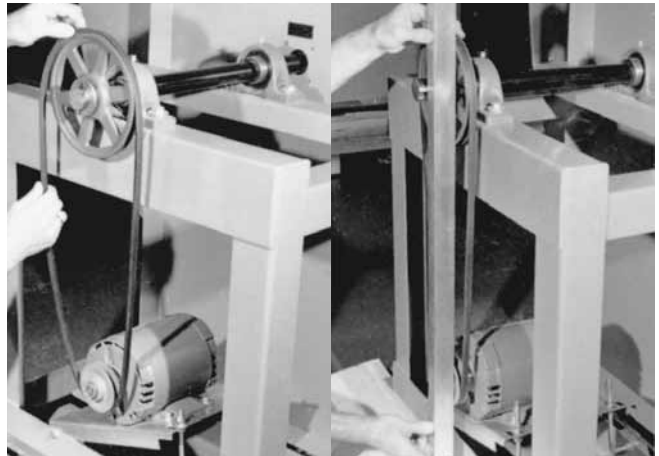

5. Install drive belt(s). Belts should not be forced over pulleys. Align motor and shaft pulleys with a straight edge. Tighten all set screws.



3. If supplied, install taperlock bushing into shaft pulley.



6. Adjust belt tension.
See page 6 for belt tensioning instructions.

Installation

Inspect the unit for any damage and report it to the shipper immediately. Also, check to see that all accessory items are accounted for.

Move the fan to the desired location and fasten securely through mounting holes provided in the base angles. The unit must be set level (shimming may be necessary). Flexible duct connections and vibration isolators should be used where noise is a factor.

The motor voltage and ampere rating must be checked for compatibility with the electrical supply prior to final electrical connection. Supply wiring to the fan must be properly fused, and conform to local and national electrical codes.

The discharge is factory set as specified by customer order, however, it can be rotated to other discharge positions in the field if necessary. Removal of the housing bolts allows the discharge to be rotated to the clockwise positions below. For TAD, BD and BAD discharge positions, a portion of the frame angle must be removed.

Clockwise rotation shown. Counterclockwise discharge positions are a mirror image of those shown. Fan rotation is always specified from the drive side of the housing.

Discharge Positions

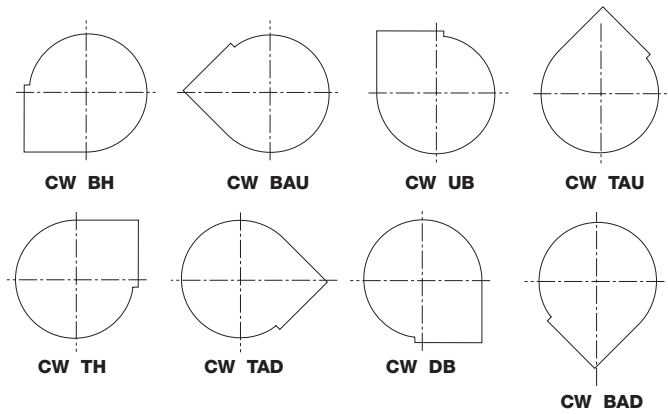

Affect of Installation on Performance

Restricted or unstable flow at the fan inlet can cause pre-rotation of incoming air or uneven loading of the fan wheel, yielding large system losses, increased sound levels and structural failure of the fan wheel. Free discharge or turbulent flow in the discharge ductwork will also result in system effect losses.

The examples below show the system layout and inlet and discharge configurations which can affect fan performance.

Discharge Configurations

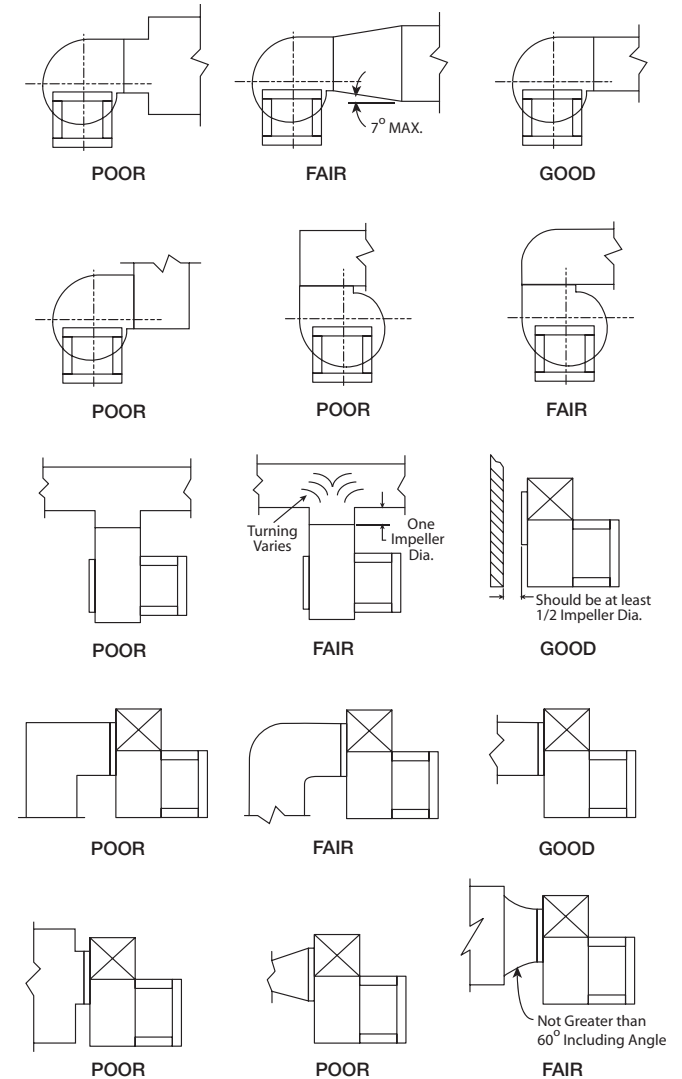

Installation of UL/cUL 762 Listed Fans for Restaurant Exhaust

The UL/cUL 762 listing for restaurant exhaust is available on Series 200 and 300 SWB fan model sizes 206 - 224 and 327 - 349 with a weatherhood. UL/cUL 762 fans are listed for a maximum operating temperature of 375°F (191°C) and includes an access door and 1 inch (25.4 mm) drain connection. An outlet guard is strongly recommended when the fan discharge is accessible. An upblast discharge is recommended. The fan discharge must be a minimum of 40 inches (1016 mm) above the roof line and the exhaust duct must be fully welded to a distance of 18 inches (457 mm) above the roof surface.

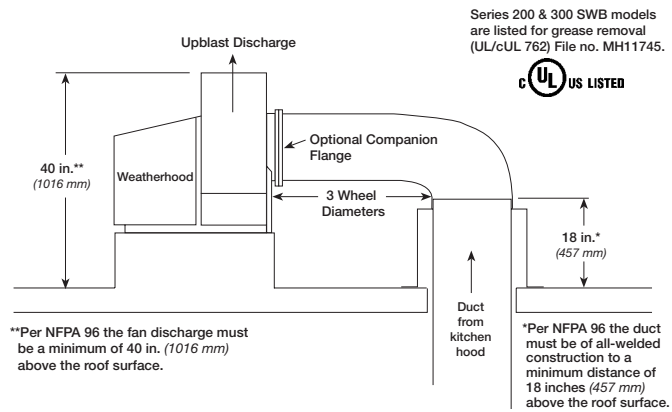

This drawing is for dimensional information only. See the latest edition of NFPA 96 Standard for Ventilation Control and Fire Protection of Commercial Cooking Operations for detailed installation instructions, materials, duct connections and clearances.

Pre-Starting Checks

WARNING
Always disconnect power before working on or near a fan. Lock and tag the disconnect switch or breaker to prevent accidental power up.
CAUTION
When servicing the fan, motor may be hot enough to cause pain or injury. Allow motor to cool before servicing.
CAUTION
Precaution should be taken in explosive atmospheres.

Alignment of Pulleys and Belts

Check pulleys and belts for proper alignment to avoid unnecessary belt wear, noise, vibration and power loss. Motor and drive shafts must be parallel and pulleys in line as shown below.

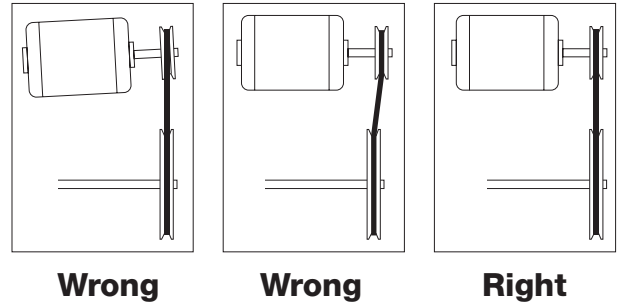

The adjustable motor pulley is set at the factory for the fan RPM specified by the customer. Fan RPM can be increased by closing or decreased by opening the adjustable motor pulley. Multigroove variable pitch pulleys must be adjusted an equal number of turns open or closed. Any increase in fan speed represents a substantial increase in load on the motor.

To avoid motor overheating and possible burnout, motor load amperes should always be checked and compared to nameplate rating when fan speed is increased.

Wheels

Wheels must rotate freely and not rub on the inlet venturi. Model SWB wheels overlap the inlet venturi as shown in Figure 1. Refer to the SWB fan wheel overlap and radial gap chart for proper dimensions.

Models SFD and SFB wheels do not overlap the venturi, but have a gap between the inlet venturi and the wheel (Fig. 2). Wheel position is preset at the factory and the unit is test run. Wheel movement may occur during shipment or installation and wheel alignment may be necessary.

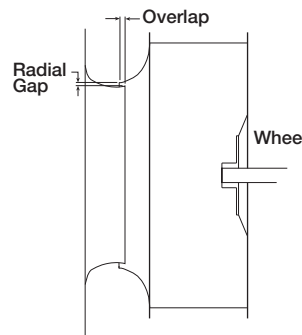

Model SWB
Fig. 1

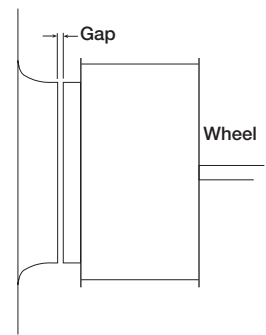

Model SFD or SFB
Fig. 2



On belt drive units, centering can be accomplished by (a) loosening the inlet cone bolts to move the inlet cone or by (b) loosening the bearings in order to move the shaft. Wheel and inlet cone overlap can be adjusted by loosening the wheel hub set screws and moving the wheel to the desired position. Tighten all fasteners and set screws securely and realign drive pulleys after adjustment.

Approximate Wheel Clearance Dimensions										
Unit Size					SWB			SFD	SFB	
SFD	SFB	SWB Series 100	SWB Series 200	SWB Series 300	Overlap	Overlap Tolerance	Radial Gap	Gap	Gap	
inches (mm)										
6		106	206		—	—	—	3/8 (10)	—	
7.5		107	207		—	—	—	3/8 (10)	—	
9	9	108	208		—	—	—	1/2 (13)	1/2 (13)	
10	10	110	210		3/8 (10)	1/4 (6)	5/32 (4)	1/2 (13)	1/2 (13)	
	12		212		3/8 (10)	1/4 (6)	5/32 (4)	—	1/2 (13)	
		113	213		7/16 (11)	1/4 (6)	5/32 (4)	—	1/2 (13)	
	15	115	215		1/2 (13)	1/4 (6)	5/32 (4)	—	1/2 (13)	
		116	216		1/2 (13)	1/4 (6)	5/32 (4)	—	—	
	18	118	218		5/8 (16)	3/8 (10)	5/32 (4)	—	1/2 (13)	
	20	120	220		5/8 (16)	3/8 (10)	5/32 (4)	—	5/8 (16)	
	22		222		1 1/16 (18)	3/8 (10)	5/32 (4)	—	5/8 (16)	
		124	224		3/4 (19)	3/8 (10)	5/32 (4)	—	—	
	25				—	—	—	—	3/4 (19)	
	27		327		7/8 (22)	1/4 (6)	3/16 (5)	—	3/4 (19)	
	30		330		15/16 (24)	3/8 (10)	3/16 (5)	—	3/4 (19)	
			333		1 1/16 (27)	3/8 (10)	3/16 (5)	—	—	
			336		1 3/16 (30)	3/8 (10)	3/16 (5)	—	—	
			340		1 1/4 (32)	3/8 (10)	1/4 (6)	—	—	
			344		1 7/16 (37)	3/8 (10)	5/16 (8)	—	—	
			349		1 9/16 (40)	1/2 (13)	5/16 (8)	—	—	

Wheel Rotation

Rotation direction of the wheel is critical and incorrect rotation will result in reduced air performance, increased motor loading and possible motor burnout.

Check wheel rotation by momentarily energizing the unit and noting if rotation is in the same direction as the airflow at the outlet and conforms to the rotation decal affixed to the unit.

NOTE

Models SFD and SFB units should be operated only when attached to the system for which they were designed. Without proper system static pressure, the motor could be overloaded.

Wheels as viewed from the drive side:

Backward Inclined

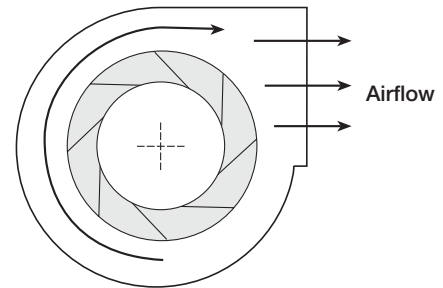

Forward Curved

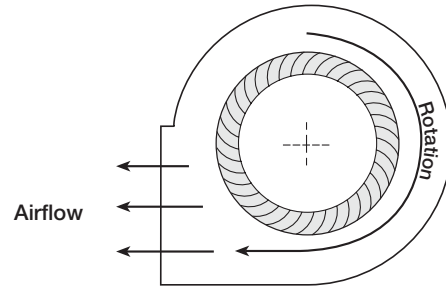

Airfoil

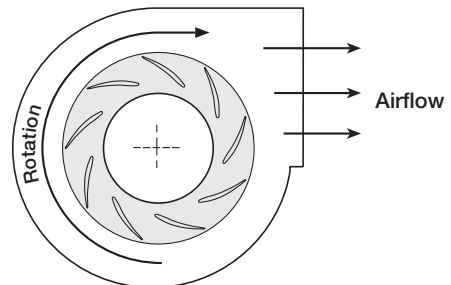

Blower Maintenance (Belt Drive)

Belts tend to stretch after a period of time. They should be periodically checked for tension and wear. When replacing belts, use the same type as supplied with the unit. Replacement of belts should be accomplished by loosening the tensioning “L-Bolts” so the belts may be removed by hand. Do not force belts on or off as this may cause breakage of cords and lead to premature belt failure.

Belt tension should be adjusted to allow 1/64 in. of belt deflection per 1 in. of belt span. For example, a 16 in. belt span should have 16/64 in. or 1/4 in. of deflection with moderate thumb pressure at mid-point between the pulleys. (Fig. 3). Refer to Greenheck’s Product Application Guide, “Measuring Belt Tension” for additional information—FA/127-11 found online at www.greenheck.com under the library section.

Fig. 3

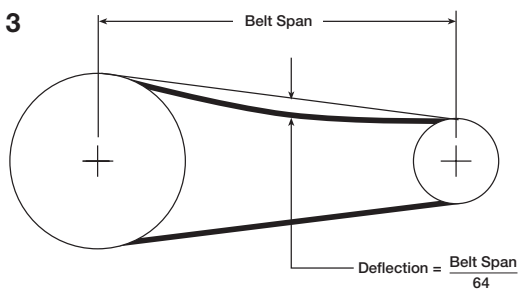

Shaft bearings are the most critical moving part of a fan. Therefore, special attention should be given to keeping the bearings clean and well lubricated. Proper lubrication provides for reduction in friction and wear, transmission and dissipation of heat, extended bearing life and prevention of rust.

In order for a lubricant to fulfill these tasks, the proper grease applied at regular intervals is required. See the recommended bearing lubrication schedule below.

If unusual conditions exist - temperatures below 32°F or above 200°F, moisture or contaminants - more frequent lubrication is required.

Recommended Bearing Lubrication Schedule					
Relubrication Schedule in Months					
Standard Grease					
Fan RPM	Bearing Bore, inches				
	1/2 - 1	1 1/8 - 1 1/2	1 5/8 - 1 7/8	1 15/16 - 2 3/16	2 7/16 - 3
To 250	12	12	12	12	12
500	12	12	11	10	8
750	12	9	8	7	6
1000	12	7	6	5	4
1250	12	6	5	4	3
1500	12	5	4	3	2
2000	12	3	3	2	1
2500	12	2	2	1	0.5
3000	12	2	1	0.5	0.25
3500	12	1	0.5	0.25	x
4000	12	0.5	0.25	x	x
5000	12	0.25	x	x	x
Number of Shots	4	8	8	10	16

- Lubrication interval is based on 12 hour per day operation and maximum 160°F housing temperature. For 24 hour per day operation, the interval should be cut in half.
- Lubricant should be added with the shaft rotating and until clean grease is seen purging from the bearing. The lubrication interval may be modified based on the condition of the purged grease. If bearing is not visible to observe purged grease, lubricate with number of shots indicated in chart for bore size.
- For conditions including high temperatures, moisture, dirt or excessive vibration, consult the factory for a specific lubrication interval for your application.
- Lubricant should be a high quality lithium complex grease conforming to NLGI Grade 2. Factory recommends Mobilux EP-2.
- The use of synthetic lubricants will increase lubrication intervals by approximately 3 times.

In addition to lubricating the bearings at specified intervals, set screws in the bearing collars should be checked for tightness. A bearing collar which has loosened will cause premature failure of the fan shaft. Fasteners attaching the bearings to the drive frame should also be checked.

Motor Maintenance (Belt & Direct Drive)

Motor maintenance is generally limited to cleaning and lubrication (where applicable). Cleaning should be limited to exterior surfaces only. Removing dust and grease buildup on the motor housing assures proper motor cooling. Use caution and do not allow water or solvents to enter the motor or bearings. Under no circumstances should motors or bearings be sprayed with steam, water or solvents.

Many fractional horsepower motors are permanently lubricated for life and require no further lubrication. Motors supplied with grease fittings should be greased in accordance with the manufacturer’s recommendations.

Wheel and Fastener Maintenance

Wheels require very little attention when exhausting clean air, however, air heavily laden with grease or dirt will tend to accumulate on the wheel causing unbalance. Wheels exhausting dirty or grease-laden air require frequent cleaning to assure smooth and safe operation.

All fasteners, including set screws in the bearing collars, should be checked for tightness each time maintenance checks are performed.

A proper maintenance program will help preserve the performance and reliability designed into the fan.

Parts List

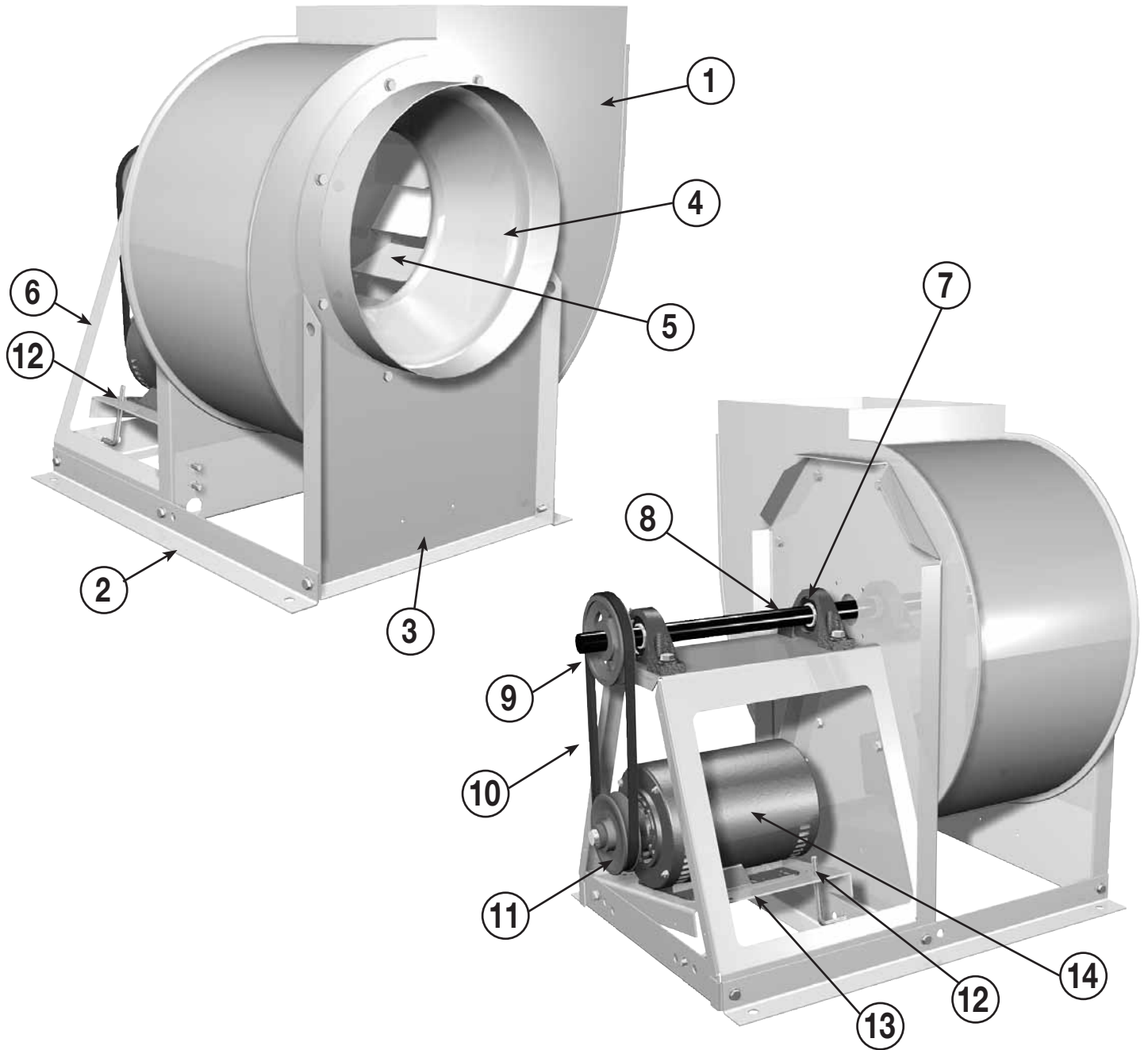

Always provide the unit model and serial number when requesting parts or information.

Replacement Parts

- | | | |
|-----------------------------|--------------------------|---------------------------|
| 1. Scroll housing | 6. Drive frame assembly | 11. Motor pulley |
| 2. Drive frame - base angle | 7. Pillow block bearings | 12. Belt tensioning bolts |
| 3. Intake support panel | 8. Fan shaft | 13. Motor plate |
| 4. Inlet ring and cone | 9. Shaft pulley | 14. Motor |
| 5. Wheel (specify rotation) | 10. Belt | |

Troubleshooting

Problem	Cause	Corrective Action
Excessive Noise	Wheel Rubbing Inlet	Adjust wheel and/or inlet cone. Tighten wheel hub or bearing collars on shaft.
	V-Belt Drive	Tighten sheaves on motor/fan shaft. Adjust belt tension. Align sheaves properly (see page 4). Replace worn belts or sheaves.
	Bearings	Replace defective bearing(s). Lubricate bearings. Tighten collars & fasteners.
	Wheel Unbalance	Clean all dirt off wheel. Check wheel balance, rebalance in place if necessary.
Low CFM	Fan	Check wheel for correct rotation. Increase fan speed.*
	Duct System	See page 4.
High CFM	Fan	Resize ductwork. Access door, filters, grills not installed.
	Duct System	Change obstructions in system. Use correction factor to adjust for temperature/altitude. Resize ductwork. Clean filters/coils. Change fan speed.*
Static Pressure Wrong	Duct system has more or less restriction than anticipated	Check rotation of wheel. Adjust fan speed.
High Horsepower	Fan	Check rotation of wheel. Reduce fan speed.
	Duct System	Resize ductwork. Check proper operation of face and bypass dampers. Check filters and access doors.
Fan Doesn't Operate	Electrical Supply	Check fuses/circuit breakers. Check for switches off. Check for correct supply voltage.
	Drive	Check for broken belts. Tighten loose pulleys.
	Motor	Assure motor is correct horsepower and not tripping overload protector.
Overheated Bearing	Lubrication	Check for excessive or insufficient grease in the bearing.
	Mechanical	Replace damaged bearing. Relieve excessive belt tension. Align bearings. Check for bent shaft.

NOTE: Always provide the unit model and serial numbers when requesting parts or service information.

*Always check motor amps and compare to nameplate rating. Excessive fan speed may overload the motor and result in burnout.

Warranty

Greenheck warrants this equipment to be free from defects in material and workmanship for a period of one year from the shipment date. Any units or parts which prove to be defective during the warranty period will be replaced at our option when returned to our factory, transportation prepaid. Motors are warranted by the motor manufacturer for a period of one year. Should motors furnished by Greenheck prove defective during this period, they should be returned to the nearest authorized motor service station. Greenheck will not be responsible for any removal or installation costs.

As a result of our commitment to continuous improvement, Greenheck reserves the right to change specifications without notice.

Greenheck Centrifugal Utility Fan catalog provides additional information describing the equipment, fan performance, available accessories, and specification data.

AMCA Publication 410-96, Safety Practices for Users and Installers of Industrial and Commercial Fans, provides additional safety information. This publication can be obtained from AMCA International, Inc. at www.amca.org.

