

# Roof Curbs, Extensions and Equipment Supports

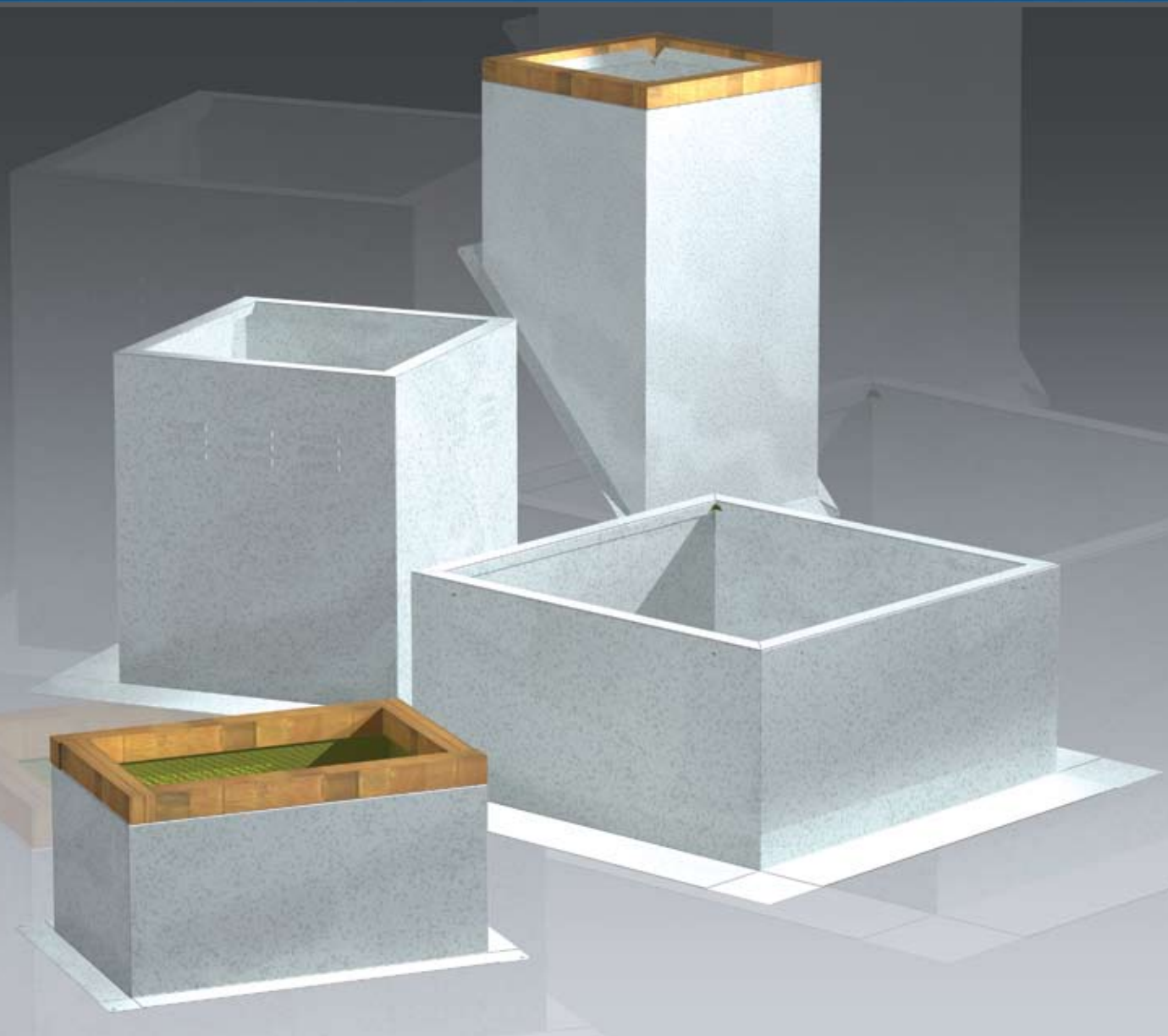

BUILDING VALUE IN AIR.



August  
2008

# Roof Curbs & Extensions



Prefabricated roof curbs reduce installation time and costs by ensuring compatibility between the fan, curb and roof opening. A wide variety of roof curbs are available including: flanged, straight-sided, canted, pitched, ridged, vented, and sound-absorbing.

Extensions raise the fan discharge and can provide an accessible mounting location for dampers. Insect screen bases and vented extensions are also available.

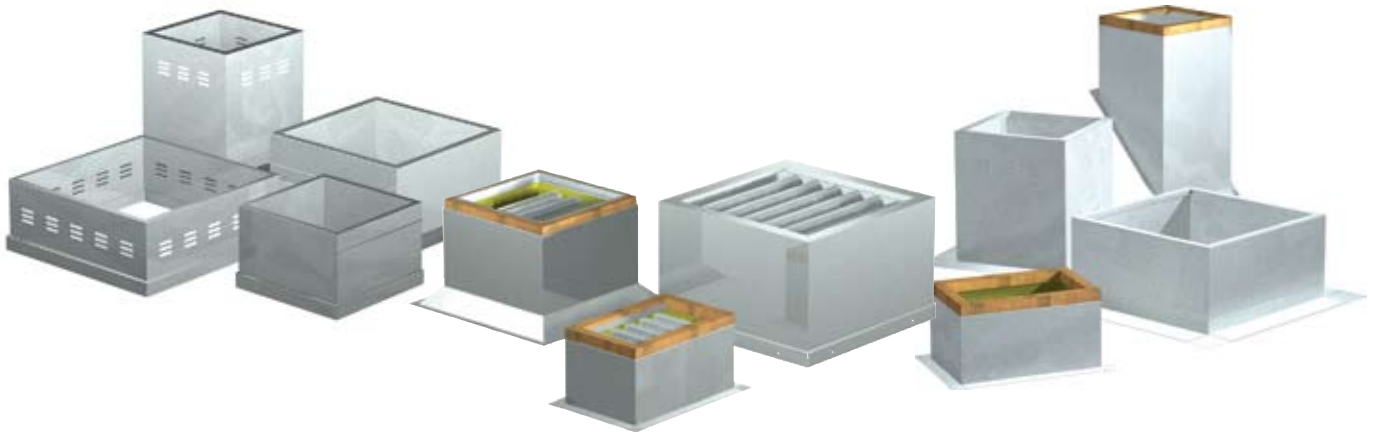

## Quick Delivery and Quick Build Programs

More than 50 configurations are stocked in our strategically located Greenheck warehouses. Greenheck's Quick Delivery (QD) program includes hundreds of in-stock ventilation products and accessories available for shipment to your job site in less than 24 hours.

Our Quick Build (QB) program ensures rapid response time with your needs dictating manufacturing time. Your custom product configuration can be manufactured in one, three, five, or ten days then shipped to your job site.



## Leading Edge Technical Support



When you need extensive product information, look no further. Greenheck products are supported by the industry's best product literature, including catalogs, Installation, Operation and Maintenance Manuals (IOM), electronic media, Computer Aided Product Selection (CAPS) program and more. All of these can be found at [www.greenheck.com](http://www.greenheck.com)

Count on personal service and expertise from our national and international representative organizations. To locate your nearest Greenheck representative, call 715-359-6171 or visit our website at [www.greenheck.com](http://www.greenheck.com)

## Model Number Code

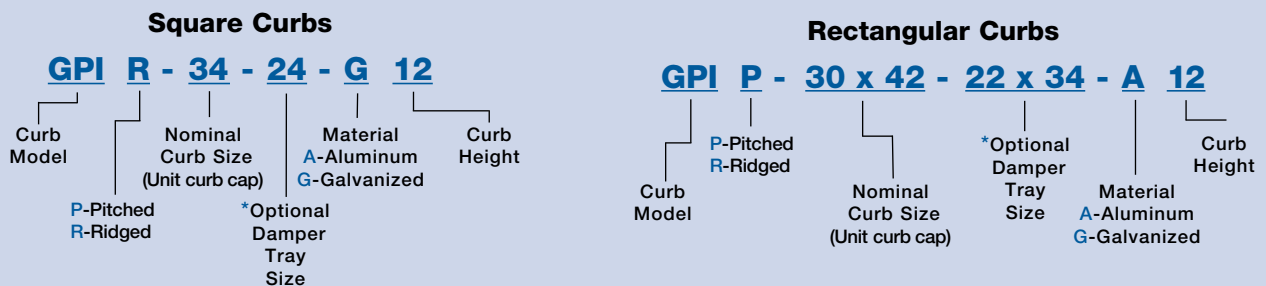

\*Shown only when specified

# Model GPI Standard Construction Features

**INSULATION** - Ridged fiberglass insulation is standard on all GPI curbs. The insulation is securely attached at both the top and bottom with an insulation tray so it will not have any exposed ends. Three pound density insulation is available in 1, 1½, and 2-inch thicknesses.

**LAP JOINTS** - Wood nailers attached to GPI curbs consist of notched and lapped joints to ensure strength and durability.

**FORMED BODY CURB** - Curbs are perfectly formed on three sides and have only one welded seam to ensure a strong square curb.

**CONSTRUCTION** - Curb sizes under 50 inches square are 18 gauge galvanized steel or 0.064 aluminum. Curb sizes 50 inches square and greater are 16 gauge galvanized steel or 0.080 aluminum.

**OPTIONAL COATINGS** - A wide variety of coatings and colors are available:

Decorative coatings are available in sixteen standard colors.

Protective coatings are available in five electrostatically applied powders providing a selection for most environments.

*All coatings and relative resistance charts can be found in Greenheck's Product Application Guide for Performance Coatings for Ventilation Products.*

**OPTIONAL SECURITY BARS** - Model GPI with security bars is available up to 50 by 92 inches to prevent unlawful entry. The bars consist of 1/2-inch diameter A-36 mild steel, welded 6 inches apart from one another and are powder coated.

**OPTIONAL DAMPER TRAY** - Designed to hold a standard Greenheck damper. The design includes flanges, which allow the damper to be placed in the tray and fastened.

**OPTIONAL CURB SEAL** - This rubber seal between the fan and the curb cap is available to ensure proper performance of the fan. The seal also helps prevent insects and moisture from entering and reduces vibration transmission in the ductwork.

**OPTIONAL LINER (Double Shell)** - Available for installations where it is not desirable for insulation to be exposed to the airstream.

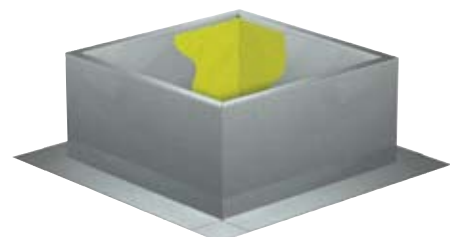

# Roof Curbs

## Models GPI, GPIP and GPIR

These curbs are designed for roof decks covered with 2 to 6 inches of insulation. Model GPI is for use on flat roofs, GPIP for pitched roofs and GPIR is available for ridged (double pitched) roofs. They are mounted directly to the roof deck before the insulation is applied, then roofed and flashed to the top of the wood nailer for weather tightness. Models GPI, GPIP and GPIR are standard with fully welded construction, 1-inch insulation and 2-inch flashing flange. Models are available in heights of 12 to 24 inches.

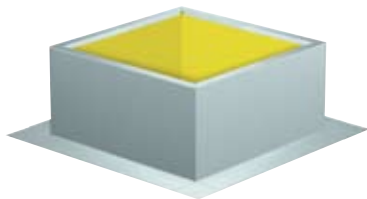
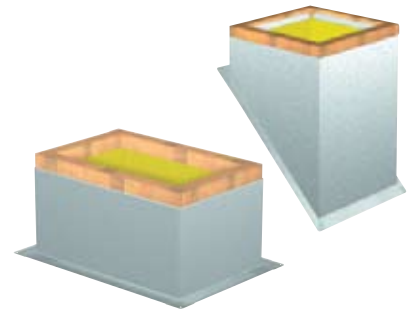

## Models GPF, GPFP and GPFR

These curbs are designed for non-insulated roof decks. Model GPF for flat roofs, GPFP for pitched roofs and GPFR is available for ridged (double pitched) roofs. Models are mounted directly to the roof deck, then roofed and sealed to the 5-inch flashing flange. Models GPF, GPFP and GPFR are standard with fully welded construction and 1-inch insulation. Models are available in heights of 8 to 24 inches.

## Model GPS

The GPS curbs are designed for use on flat, non-insulated roof decks. They are mounted directly to the deck structure with a 1 $\frac{1}{8}$ -inch flashing flange, then roofed and flashed to the top of the wood nailer for weather tightness. For pitched or ridged applications, use models GPIP, GPIR, GPFP, or GPFR. Model GPS consists of a fully welded body and 1-inch insulation. Model GPS is available in heights of 8 to 18 inches.

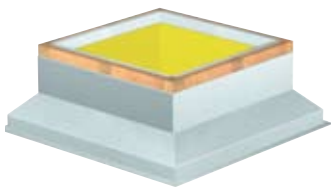
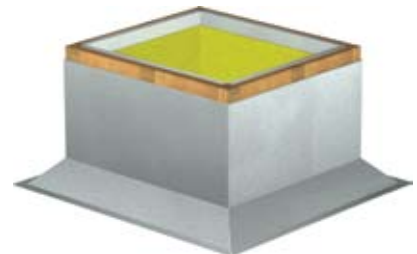

## Model GPR (with raised cant)

This curb is designed for use on flat, insulated roof decks. It is mounted directly to the deck structure with a 1 $\frac{1}{8}$ -inch flashing flange, then roofed and flashed to the top of the wood nailer for weather tightness. For pitched or ridged applications, use models GPIP, GPIR, GPFP, and GPFR. Model GPR has fully welded construction and 1-inch insulation. Available heights for model GPR are 8 to 18 inches. The raised cant is available up to 6 inches in height.

## Model GPFV

The GPFV vented roof curb is typically used for kitchen applications; the vents allow hot air and gases to escape between the ductwork and roof curb. This curb is designed for use with Greenheck fan models CUBE, CUE or USGF to provide the required 40-inch minimum discharge height above the roof line per NFPA 96. This curb is to be used on non-insulated flat roof decks. Model GPFV is mounted directly to the roof deck structure, roofed to the vertical surface and sealed to the 5-inch flashing flange. It is available in nine different sizes.



# Equipment Supports and Curb Extensions

## Models GESS and GESR

These equipment supports are designed for use on both insulated (GESR) and non-insulated (GESS) flat roof decks. They are mounted directly to the deck structure, then roofed and flashed for weather tightness. A variety of sizes and widths are available. (Refer to CAPS for more details.) Models GESS and GESR are available in welded aluminum or galvanized steel. Available in heights of 8, 12 and 14 inches and widths of 4, 6 and 8 inches.



## Models GPE and GPEX

The extended base models mount between the fan and roof curb. Heights range from 12 to 24 inches in 1/2-inch increments. Models consist of welded aluminum or galvanized steel. The GPE is designed with an access door to provide easy access to the damper and damper actuator as well as fulfilling additional height requirements. The GPEX is also designed to provide additional height requirements without an access door.

## Model VCE

The VCE vented curb extension is typically used in kitchen applications, where the vents allow hot air and gases to escape between the ductwork and the roof curb. Designed for use with an 8-inch high roof curb and Greenheck fan models CUBE, CUE or USGF to provide the required 40-inch minimum discharge height above the roof line per NFPA 96. Model VCE consists of galvanized steel or welded aluminum.



## Model ISB

Insect screen bases are available for applications where the building must be completely free of insects, as in food processing operations. Insect screen bases mount between the fan and the roof curb and provide an additional 6-inches of height. Two bolted access doors are provided for removal and cleaning of the screen. Model ISB is constructed of galvanized steel or aluminum with a fine mesh screen made of aluminum or stainless steel.

## Adapters and Reducers

Used to adapt or reduce the standard fan curb cap dimensions to a nonstandard specified curb size within 10 inches of standard. Adapters and reducers are most commonly used to match new fans to existing roof curbs. Construction consists of welded galvanized steel or aluminum.



Model AT Sound Curbs are designed to reduce fan generated sound traveling down the ductwork without adversely affecting fan performance. Air passes between the streamlined baffles allowing the fan sound to be absorbed and dissipated within the curb area preventing it from entering the building.

Each perforated aluminum baffle section is filled with fiberglass wool. Spring steel wire holding clips secure the aluminum baffle. The assembly is a rigid, durable section which will not warp or twist out of shape. The permanently constructed baffles are easy to remove for access to dampers or for occasional cleaning. No tools are required. Slight pressure is required to spread the spring wire to release it.

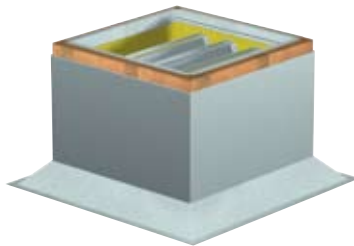

### Model ATS

This curb is designed for use on flat, non-insulated roof decks. It is mounted directly to the roof with a 1 $\frac{1}{8}$ -inch flashing flange then flashed to the top of the wood nailer for weather tightness. This style is recommended when height is not objectionable and where smaller roof openings are desired. Model ATS consists of welded seams and canted construction which is fully insulated with rigid fiberglass board.

### Model ATR

This roof curb is designed for use on flat, insulated roof decks. It is mounted directly to the deck structure with a 1 $\frac{1}{8}$ -inch flashing flange, then roofed and flashed to the top of the wood nailer for weather tightness. The curb body is recessed into the roof in order to achieve a lower overall height. Roof openings must be as large as the curb body. Model ATR consists of continuous welded seams and canted construction which is fully insulated with rigid fiberglass board.



### Model ATI, ATIP and ATIR

These curbs are designed for roof decks and consist of continuous welded seams. Model ATI for use on flat, non-insulated roofs, ATIP for pitched roofs and ATIR for ridge (double pitched) roofs. They are mounted directly to the roof deck with a 2-inch flashing flange before the insulation is applied, then roofed and flashed to the top of the wood nailer for weather tightness.



### Model ATE

Sound attenuating curb extensions are designed to reduce fan generated sound traveling down the ductwork. Model ATE is an extension to be mounted between the fan and the roof curb. It is available in heights of 18 to 24 inches.

## Special Purpose Roof Curbs

**Model H-GPF** — This roof curb is specifically designed for high wind applications up to 150 mph, used on fan models H-G, H-GB, H-CUE, and H-CUBE. Standard height is 12 inches, fully welded straight sides with a 5-inch flashing flange. See CAPS for required installation details.

**Model GPSHL** — This prefabricated roof curb is specifically designed for heavy weight fans, such as the model LSF and Greenheck's Lab Exhaust units. GPSHL is available in 16 gauge galvanized steel and 0.080 aluminum construction. Included are curb side reinforcement angles approximately every 12 inches. Available heights include 8 and 12 inches only.

**Model SD and SDP** — The severe duty curbs are specifically designed for high wind applications up to 150 mph and used on models LDP, LBP, RSFP, H-G, H-GB, H-CUE, H-CUBE, and USGF fans. Model SD is for use on flat roofs and model SDP for pitched roofs. They are attached directly to the building structure with extremely high structural design load requirements. Maximum design load is 140 psf. The severe duty curbs are 12 gauge coated steel with a 1 $\frac{3}{4}$ -inch lip on the top and a 4 inch flange on the bottom. Available heights include 12, 18 and 24 inches only. Heights greater than 18 inches are reinforced in the interior with 12 gauge x 2-inch angles.

## BASIC ADAPTER AND REDUCER DIMENSIONAL INFORMATION

Curbs without wood nailers = Adapted curb cap width and length will be 1/2-inch larger than the curb AD dimension.

Curbs with wood nailers = Adapted curb cap width and length will be 1 1/2 inches larger than the curb AD dimensions.

Minimum adapted amount = 1 1/2 inches  
Maximum adapted amount = 10 inches

### ADAPTER (Fan curb cap is smaller than existing curb)

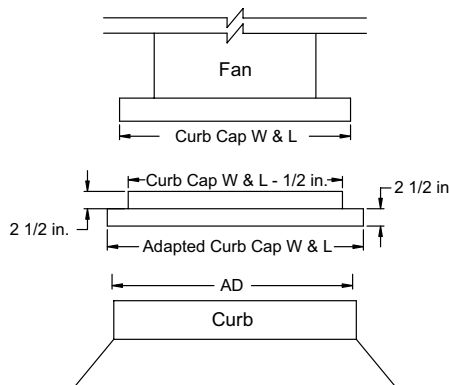

### REDUCER (Fan curb cap is larger than existing curb)

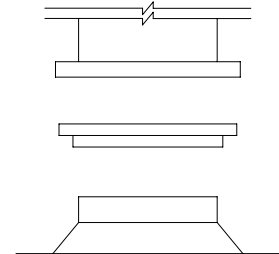

## BASIC CURB DIMENSIONAL INFORMATION

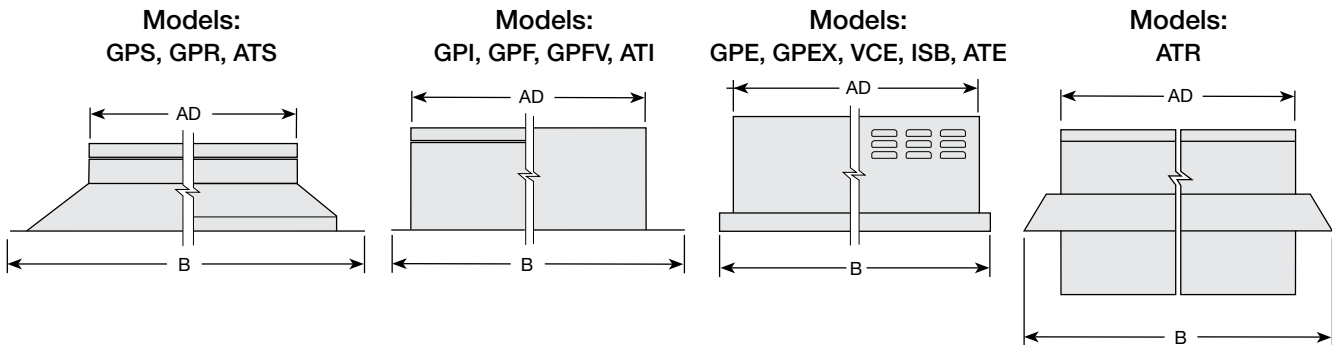

Model	Dimensions
GPI, GPS, GPR, ATR, ATS, ATI nominal wood nailer curbs	AD (actual) = 1 1/2 inches less than unit curb cap
GPF, GPFV, GPEX, VCE, ISB, ATE nominal flanged curbs	AD (actual) = 1 inch less than unit curb cap
GPS, GPR, ATS, ATR	B = AD Dimension + 8 1/4 inches
GPI, ATI	B = AD Dimension + 4 inches
GPF, GPFV	B = AD Dimension + 10 inches
GPE, GPEX, VCE, ISB, ATE	B = Same as unit curb cap dimensions

Note: AD is the actual width and length of the roof curb. Roof curbs are typically ordered using the nominal dimension which is equivalent to the unit curb cap dimension.

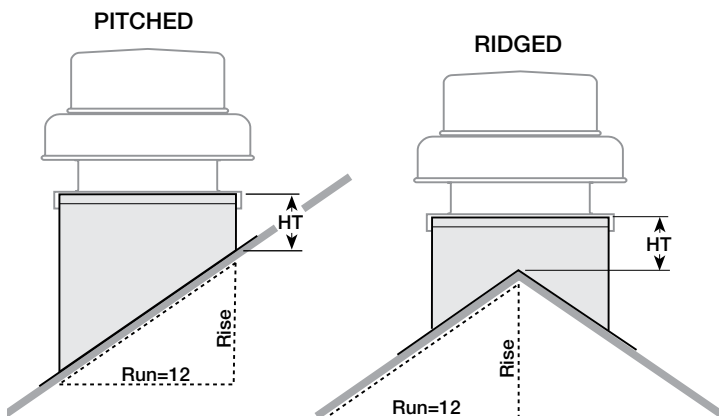
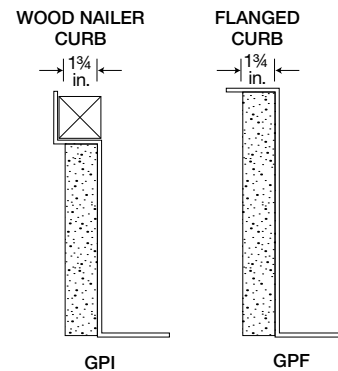

## TO ORDER PITCHED AND RIDGED CURBS

The following information is required:

1. Specify pitched or ridged.
2. Include roof rise and run (see diagrams). This will be represented as a ratio (rise:run) with run always expressed as 12 units. Units of measure must be the same (inches, centimeters, etc.).  
**EXAMPLE:** The Pitch of a roof with a Rise of 3 inches and a Run of 12 inches equals a ratio of 3:12.
3. When specifying a rectangular curb, note whether the slope runs in the direction of the short side or the long side of the curb.

# Typical Installation

Greenheck's straight-sided roof curbs are designed for general exhaust or supply applications.

## General Flashed Roof Installation:

1. Remove roofing material where roof penetration is to be made and provide a 10-inch wide clearance around perimeter of hole in roof.
2. Apply roofing cement around roof opening.
3. Place and center roof curb over hole in roof so it sits on roofing cement. Make sure the roof curb is placed over an adequate support structure to handle the weight and wind load of curb and fan assembly.
4. Secure roof curb to roof deck using a minimum of three lag screws, anchor bolts, or suitable metal fasteners per side and two per corner (fasteners by others).
5. Install insulation if required.
6. Field flash – flashing should extend at least 4 inches beyond the horizontal flange on roof curb. Flashing should also extend over the top flange surface where there is a wood nailer for a leak resistant installation.
7. Apply Curb Seal (rubber gasket) to the top of roof curb to seal fan or ventilator to curb to prevent air leaks and water penetration and to reduce the transmission of vibration from fan to building.
8. Place fan or ventilator onto roof curb and center.
9. Secure fan's curb cap to the roof curb using a minimum of two lag screws, anchor bolts, or suitable metal fasteners per side (fasteners by others).

### Notes:

- For rubber roofs, refer to roof manufacturer for roof curb installation.
- No replacement parts available.
- For installation of specialty curbs and high wind curbs, see CAPS for installation details.



## Building Value in Air

Greenheck delivers value to mechanical engineers by helping them solve virtually any air quality challenges their clients face with a comprehensive selection of

top quality, innovative air-related equipment. We offer extra value to contractors by providing easy-to-install, competitively priced, reliable products that arrive on time.

And building owners and occupants value the energy efficiency, low maintenance and quiet dependable operation they experience long after the construction project ends.

## Our Warranty

Greenheck warrants this equipment to be free from defects in material and workmanship for a period of one year from the purchase date. Any units or parts which prove defective during the warranty period will be replaced at our option when returned to our factory, transportation prepaid. Motors are warranted by the motor manufacturer for a period of one year. Should motors furnished by Greenheck prove defective during this period, they should be returned to the nearest authorized motor service station. Greenheck will not be responsible for any removal or installation costs.

*As a result of our commitment to continuous improvement, Greenheck reserves the right to change specifications without notice.*



Prepared to Support  
Green Building Efforts

