

Rooftop Ventilator with Packaged Cooling & Heating Model RV/RVE

• Institutional • Commercial • Industrial

- 800 - 9,500 cfm
- 3.0 in. wg External Static Pressure
- Indirect Gas, Hot Water, Electric Heating
- Packaged DX (5-30 tons), Chilled Water, Split DX Cooling
- Optional Energy Recovery
- Optional Return Air



Product Overview

The model RV(E) is a pre-engineered rooftop ventilation unit specifically designed to condition and deliver mixtures of outdoor and return air to a building. Varying outdoor air conditions and building loads create a serious challenge for any HVAC system. To overcome these challenges, the RV(E) includes value added features such as a factory mounted variable frequency drive (VFD) for supply air volume control, outdoor and return air dampers for mixed air control, and an onboard microprocessor system for precise temperature and humidity control. Pre-engineered features provide semi-custom flexibility while maintaining the quality, consistency, and value of a standardized product.



Model RV(E) Features

- Up to 9,500 cfm and 3 in. wg external static pressure
- 2-inch double-wall construction
- Cooling Options
 - *Integral air-cooled packaged DX*
 - R410a refrigerant
 - Modulating hot gas reheat
 - Variable capacity compressors
 - 5 to 30 tons of cooling capacity
 - Service/charging valves
 - Liquid line dryer
 - Sight glass
 - *Split system DX coil*
 - *Chilled water coil*
- Heating Options
 - *Indirect gas furnace*
 - Stainless steel construction
 - High turndown capacity
 - Power venting
 - *Electric heat*
 - SCR control
 - *Hot water coil*
- Direct-drive backward-inclined plenum fan
- Mounted and wired supply/exhaust fan VFD's
- Blower vibration isolation
- G90 galvanized exterior with paint options
- Outdoor air filters
 - MERV 8
 - MERV 13
 - Combination MERV 8/13
- Microprocessor control
 - Stand alone
 - BACnet® IP
 - BACnet® MS/TP
 - LonWorks®
- Sloped intake hood
 - Aluminum mesh filters

The Greenheck Advantage

Greenheck takes pride in offering a high quality, reliable product. We invest a great percentage of our resources into designing, testing and manufacturing products to ensure customer satisfaction.

Quality and Consistency

Greenheck's manufacturing facilities utilize an efficient, automated manufacturing process that maintains Greenheck's consistent high standard of quality.



Extensive Testing and Industry Certification



ETL Listed for electrical and overall unit safety. Every unit is tested at the factory before it is shipped to the jobsite.



AHRI Certified coils and energy wheels. To guarantee your coil is going to perform as required, check for AHRI Certification.



Energy recovery wheels are certified by the AHRI Air-to-Air Energy Recovery Ventilation Equipment Certification Program in accordance with AHRI Standard 1060. Actual performance in packaged equipment may vary. Certified ratings are available in the Certified Product Directory at www.ahridirectory.org.

The model RV(E) has been specifically designed to meet the challenges of introducing high percentages of outdoor air into a building. Features included in the RV(E) minimize energy consumption, control outdoor air volume, and maintain high levels of indoor air quality. This makes the RV(E) ideal for ventilation applications in which the supply air volume consists of 20% or more outdoor air.

Design Challenge: Conditioning High Percentages of Outdoor Air with Minimal Energy Usage

Solution

- **High capacity (6-row) cooling coil:** Provides proper dehumidification for a wide range of outdoor air conditions
- **(optional) Energy recovery wheel to precondition the outdoor air:** Mechanical heating and cooling equipment capacity reduction; reduced mechanical heating and cooling energy consumption
- **(optional) Modulating hot gas reheat coil:** Reheats dehumidified air to prevent overcooling the space
- **(optional) Variable capacity compressor:** Modulates DX cooling system to match the required load for precise temperature control and saves operational energy



Design Challenge: Controlling Outdoor Air Volume

Solution

- **Low leakage outdoor air and recirculated air dampers with modulating actuator:** Provides energy saving control sequences and simplified air balancing
- **Factory mounted and wired microprocessor controller:** Proven control sequences with easy set point adjustment and seamless integration to BMS systems
- **Energy efficient control sequences (economizer, demand control ventilation, outdoor airflow monitoring):** Economizer - maximizes free cooling; demand control ventilation - adjusts outdoor airflow to match building occupancy; airflow monitoring - stand-alone monitoring system to ensure proper ventilation and meet LEED requirements
- **Direct-drive backward-inclined plenum fans with factory mounted VFDs:** Provides precise airflow control via modulating fan speed; fast and simple airflow adjustment; eliminates belt losses and maintenance



Design Challenge: Maintaining Indoor Air Quality

Solution

- **Double-sloped insulated stainless steel drain pan:** Prevents microbial growth caused by moisture build up in the drain pan; ensures that all condensate properly drains from the unit
- **2-inch double-wall construction with R8 insulation:** Creates a barrier between the cabinet insulation and the supply airstream protecting the unit insulation from erosion; prevents unit condensation which could cause microbial growth
- **(optional) High filtration efficiency (MERV 8 or MERV 13):** Prevents airborne debris from entering the building; increases the quality of the supply air volume



RV(E) Standard and Optional Features

1

Plenum Supply Fan

- Airfoil plenum blower
- Direct-drive
- Neoprene isolation
- 12-bladed design for quiet operation
- Factory provided VFD



Plenum Exhaust Fan

- Airfoil plenum blower
- Direct-drive
- Neoprene isolation
- 12-bladed design for quiet operation
- Factory provided VFD

2

Double-Wall Construction

- 2-inch insulation secured in place between solid inner and outer panels
- Insulation density of 1.5 lbs/cu. ft.

3

Filters

- MERV 8 pre-filters
- 2-inch MERV 8 or MERV 13 final filters

Hinged Access Doors

- Stainless steel hinges
- Quarter turn latch
- Easy lift-off removable doors

4

Control Center

- 24 VAC control voltage
- Control transformer
- Disconnect switch
- UL Listed, Recognized, or Classified electrical components
- Factory prewired for single point power connection

5

Weatherhood

- 2-inch aluminum mesh filters (mist eliminating)
- Downturn intake
- Wind-driven rain prevention



Intake Weatherhood

6

Total Energy Wheel (RVE)

- Sensible and latent energy recovery
- Lightweight, segmented wheel for easy cleaning with L₁₀ rated bearing life in excess of 400,000 hours
- Permanently bonded, silica gel desiccant for latent transfer — long term durability
- Stainless steel housing

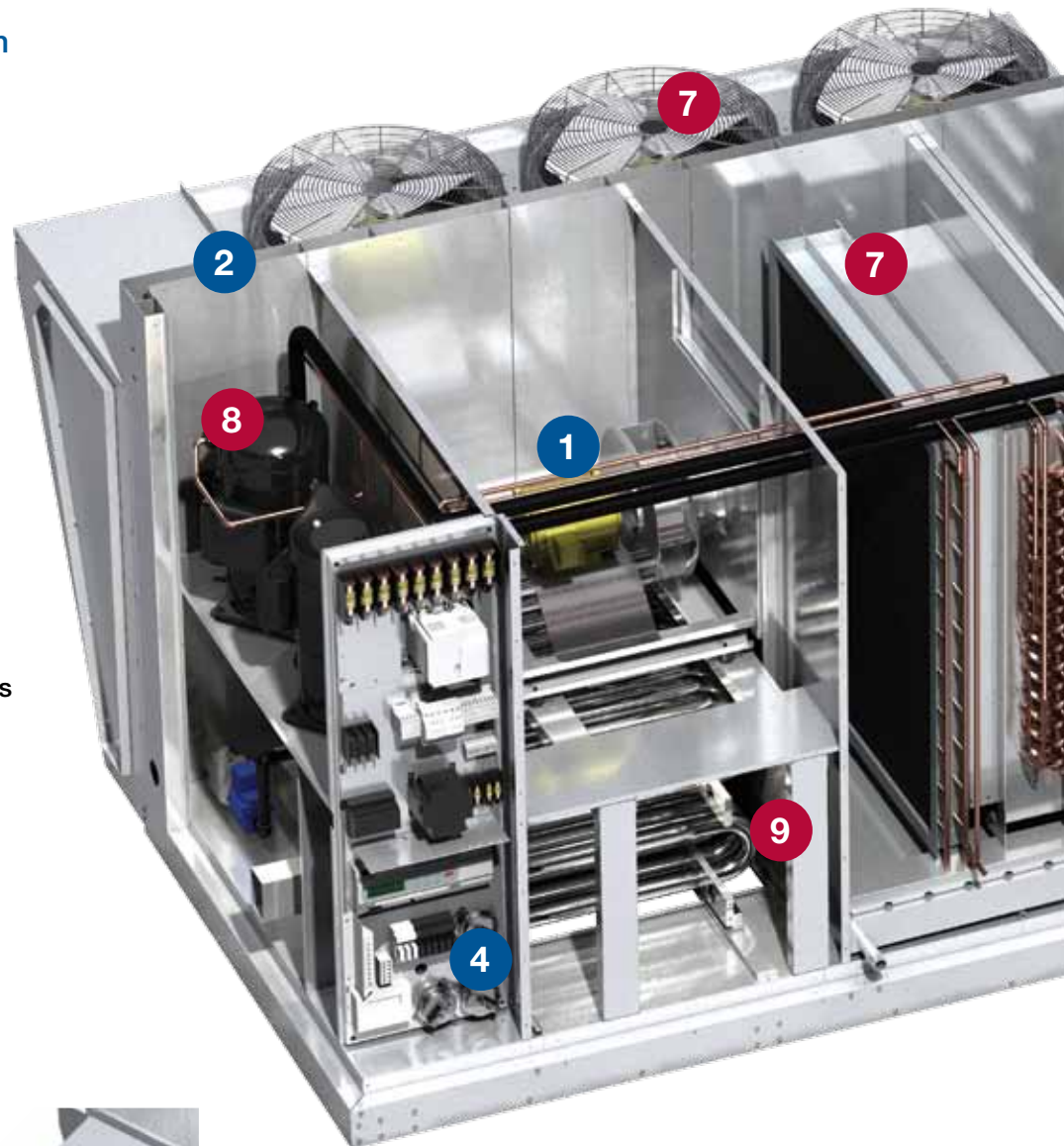

S Standard Feature **O** Optional Feature

10 Outdoor Air and Recirculated Air Dampers

- Insulated, low leakage
- Modulating actuator
- Demand control ventilation
- Economizer

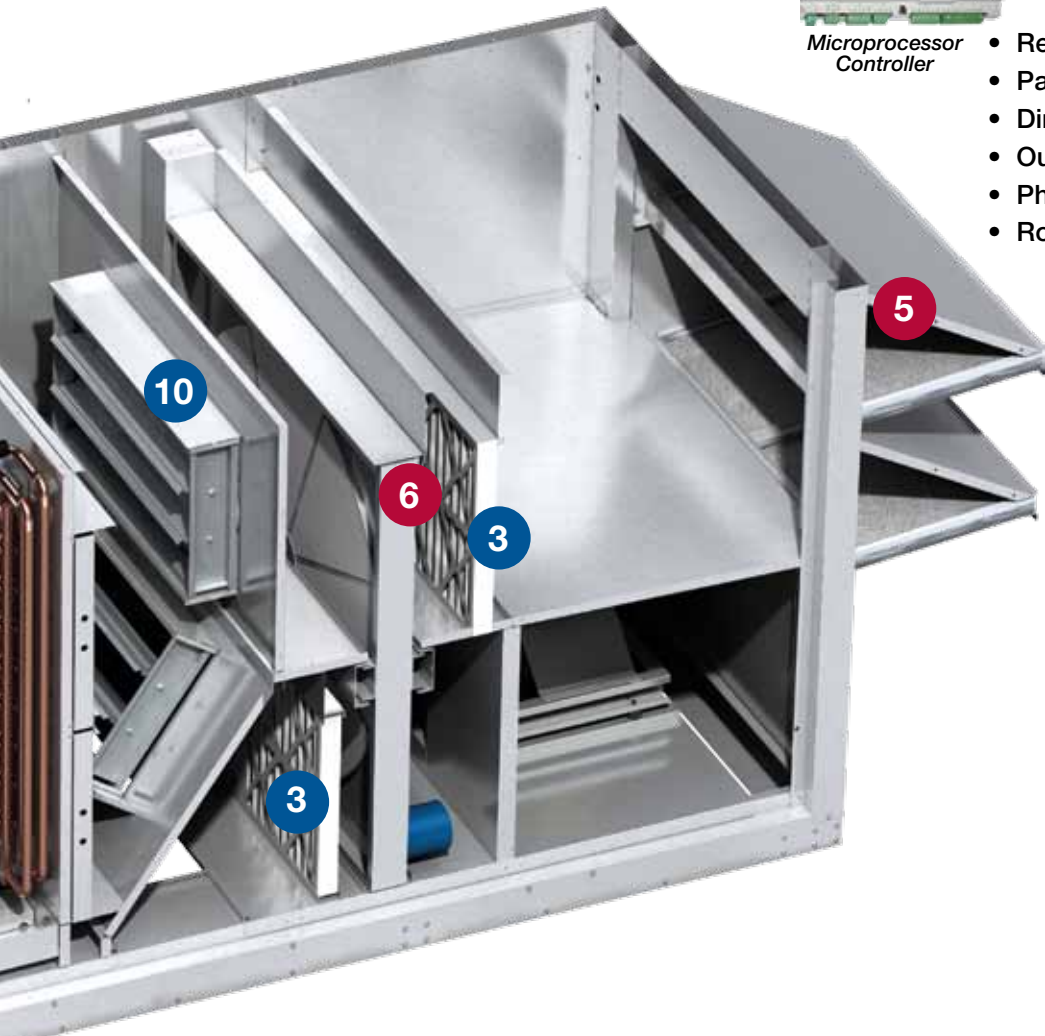

Accessories



Microprocessor Controller

- Microprocessor controller
 - BACnet or LonTalk control interface
 - Room temperature sensor
 - Room humidity sensor
- Remote panel
- Painted exteriors
- Dirty filter sensors
- Outdoor airflow monitoring
- Phase and brownout protection
- Roof curbs

9 Heating Options

- Indirect gas-fired furnace
 - Stainless steel heat exchanger – Optional 5 or 10 year extended warranty
- Electric heater
 - SCR control
 - ETL Certification
- Hot water coil



IG Heater

7 Cooling Options

- Packaged direct expansion [PDX]
 - Optional hot gas reheat
- Chilled water coil
- Split DX coil
- All coils with copper tubes and permanently expanded aluminum fins
- Mounted on a stainless steel insulated drain pan

8 Compressors

- Quiet operating hermetic, scroll-type
- 5 to 30 tons of mechanical cooling
- 1 circuit up to 10 tons
- 2 circuits over 10 tons
- Optional variable capacity compressor for lead circuit



Compressors

Reheat

- Modulating hot gas reheat
- 6 in. separation between evaporative and reheat coil components

The model RV(E) includes a microprocessor controller that is factory programmed, wired and tested prior to shipment. This controller is responsible for managing the sequence of operation, heating and cooling outputs, and safety limits for the equipment.

Standard Control Features for Microprocessor

- LCD screen that provides status readouts
- Built-in keypad for easy set point adjustment
- Integral 7-day time clock
- Auto changeover based on outdoor air conditions
- Discharge temperature control
- Heating and cooling temperature lockouts
- Building freeze protection (low discharge temperature)

Optional controls

- BMS interfacing capability (BACnet® IP, MS/TP, LonWorks®)
- Dirty filter switch
- Room temperature sensor
- Room dehumidistat
- Remote interface
- Phase and brownout protection
- Outdoor airflow monitoring



Microprocessor
Controller



Remote Interface

Unit Control Sequences

- **Constant volume sequence**
The model RV(E) provides a constant volume of supply air while maintaining the proper mixture of recirculated and outdoor air to meet the space ventilation requirements.
- **Variable volume sequence**
The model RV(E) varies the supply air to the space via a factory mounted and wired VFD. The required amount of supply air can be determined by a variety of external factors such as duct pressure.
- **Demand control sequence**
The supply air volume (100% outdoor air application), or the outdoor air volume (recirculating application) is modulated based on building occupancy as determined by a factory provided CO₂ sensor.
- **Economizer sequence**
When the outdoor air conditions are favorable for free cooling as determined by a factory provided outdoor air temperature sensor or a combination of an outdoor air temperature and dew point sensor, the recirculation damper in the model RV(E) is modulated to increase the amount of outdoor air to the space.

RV(E) Weights and Dimensions

Unit Size	Nominal tonnage (tons)	Height (H)	Width (W)	Length (L)	Intake (A)	Condensing Section (B)	Nominal weight (lbs)*
RV-35	5-15	58	81	117	22	30	2500
RV-50	10-25	70	100	130	22	36	3600
RV-80	15-30	82	100	143	27	32	4500
RVE-35	5-15	58	81	169	22	30	3600
RVE-50	10-25	70	100	184	22	36	4900
RVE-80	15-30	82	100	205	27	32	6200

All dimensions are shown in inches.

*Average unit weights are represented in this table. Actual weights will vary based on the unit configuration.

RV(E) Weights and Dimensions

Model RV

PLAN

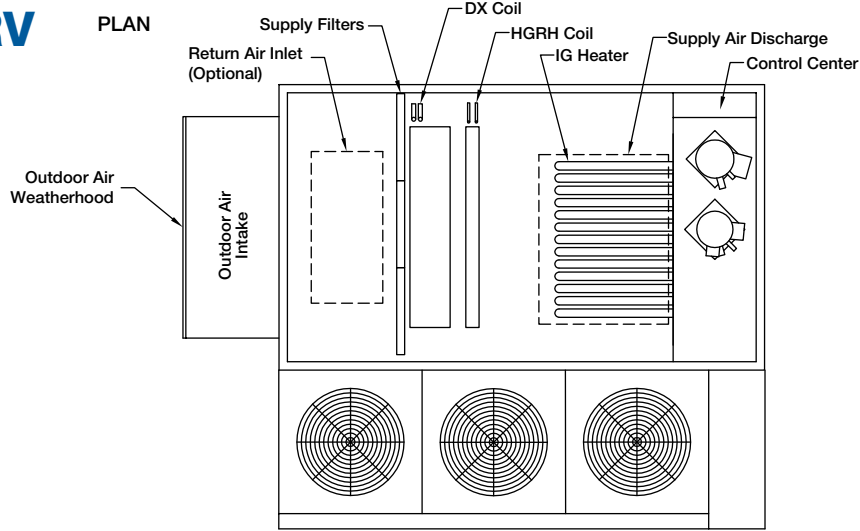

INTAKE

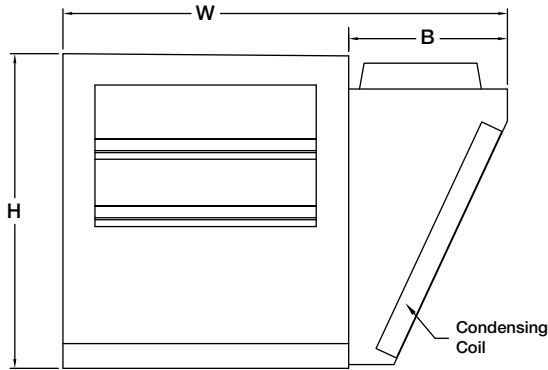

ELEVATION

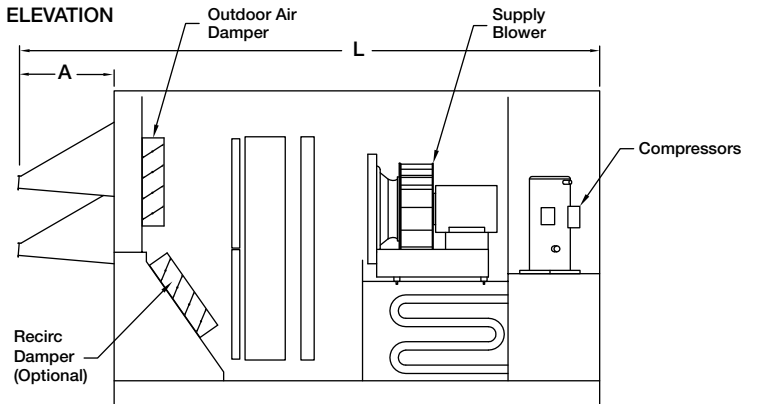

Model RVE

PLAN

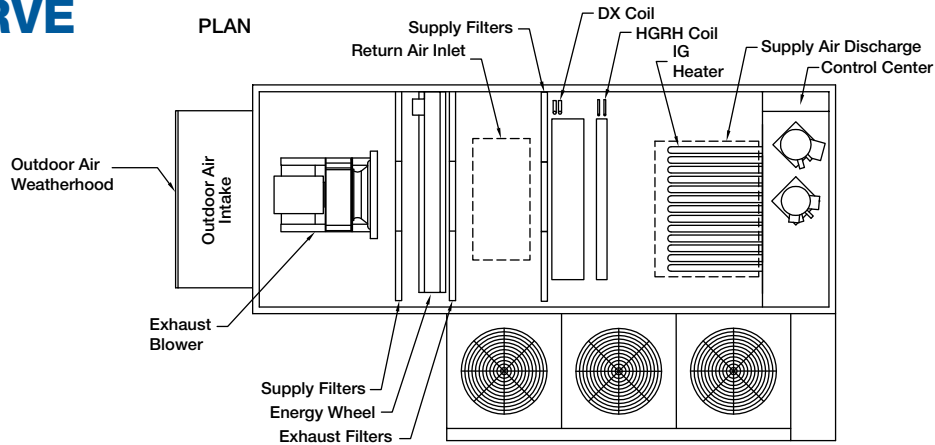

INTAKE

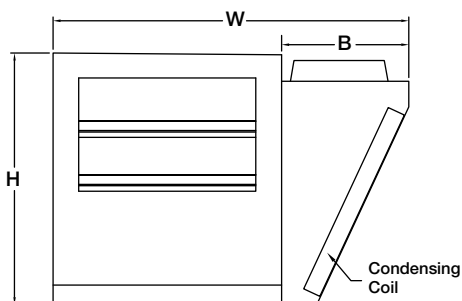

ELEVATION

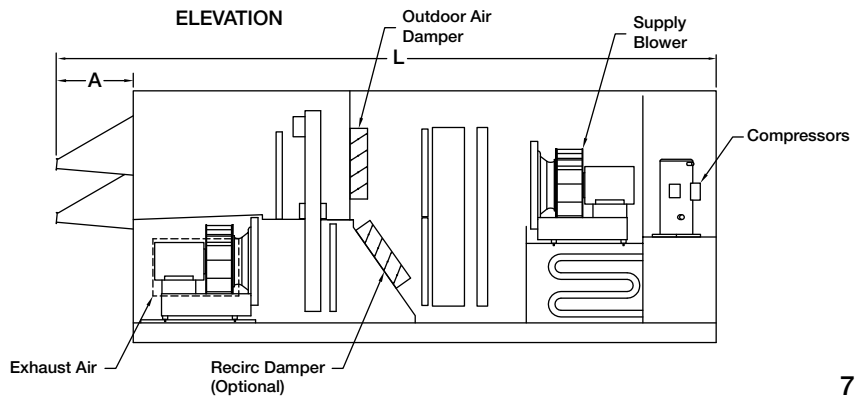

Tempered Air Products Quick Selection Guide

Model	Recovery		Heating Options				Cooling Options				Blower Type			Performance		
	Energy Wheel	Aluminum Plate	Hot Water	Indirect Gas	Electric	Wrap Around Heat Pipe	Chilled Water	Direct Expansion (DX)	Packaged Direct Expansion (DX)	Evaporative Cooling	Forward-Curved	Backward-Inclined	Airfoil Plenum	Minimum Volume (cfm)	Maximum Volume (cfm)	Maximum Static Pressure (in. wg)
ENERGY RECOVERY																
PRE-CONDITIONERS (NON-TEMPERED)	ERV	✓									✓			500	12,000	1.5
	ERV ^e	✓								✓				1,000	6,000	1.5
	MiniVent	✓								✓				300	750	1
	PV ^e		✓							✓				1,000	6,000	2
ENERGY RECOVERY WITH HEATING & COOLING (TEMPERED)	ERH	✓		✓	✓					✓				1,000	10,000	1.5
	ERCH	✓		✓	✓		✓	✓		✓				1,000	10,000	1.5
	HRE	✓			✓	✓			✓	✓				1,000	8,300	1.5
	ERT	✓		✓		✓	✓	✓			✓			1,800	10,000	3
	VersiVent	✓		✓	✓	✓	✓	✓	✓		✓	✓		2,000	10,000	3
	APEX	✓		✓		✓	✓	✓			✓		✓	10,000	20,000	2.5
ENERGY RECOVERY MODULES	ERM	✓												500	10,000	-
PACKAGED VENTILATION SYSTEMS																
ROOFTOP VENTILATORS (OPTIONAL RECIRCULATION)	RV			✓	✓	✓		✓	✓	✓			✓	1,000	9,500	3
	RVE	✓		✓	✓	✓		✓	✓	✓			✓	1,000	9,500	3
100% OUTDOOR AIR	MPX			✓	✓				✓				✓	1,000	9,000	3

Model	Airflow Options		Cooling Options				Blower Type	Performance		
	Variable Air Volume	Recirculation	Chilled Water	Direct Expansion (DX)	Packaged Direct Expansion (DX)	Evaporative Cooling	Forward-Curved	Minimum Volume (cfm)	Maximum Volume (cfm)	Maximum Static Pressure (in. wg)
MAKE-UP AIR										
DIRECT GAS-FIRED	DGK						✓	1,000	8,500	2
	DG						✓	800	15,000	2
	DGX	✓	✓	✓	✓	✓	✓	800	48,000	3
	TSU	✓	✓				✓	30,000	64,000	3
	VSU	✓	✓				✓	800	64,000	3
INDIRECT GAS-FIRED	IGK						✓	1,000	5,000	2
	IG		✓				✓	800	7,000	2
	IGX	✓	✓	✓	✓	✓	✓	800	15,000	3
HOT WATER, STEAM AND ELECTRIC	MSX	✓	✓	✓	✓	✓	✓	800	48,000	3
NON-TEMPERED	KSFD	✓					✓	400	2,100	2.5
	KSFB	✓					✓	1,000	10,500	2.5
	TSF					✓	✓	30,000	64,000	3

Our Warranty

Greenheck warrants this equipment to be free from defects in material and workmanship for a period of one year from the shipment date. Any units or parts which prove defective during the warranty period will be replaced at our option when returned to our factory, transportation prepaid. Motors are warranted by the motor manufacturer for a period of one year. Should motors furnished by Greenheck prove defective during this period, they should be returned to the nearest authorized motor service station. Greenheck will not be responsible for any removal or installation costs.

As a result of our commitment to continuous improvement, Greenheck reserves the right to change specifications without notice.



Prepared to Support Green Building Efforts

