



SKU  
SP-B150-L-QD

Job Name:  
Mark:  
Submitted By:  
Date: 04/09/2026

## Lighted Bathroom Exhaust Fan, Product # SP-B150-L-QD, 92-160 CFM

Low profile bathroom exhaust fan, Model SP-B features a forward-curved wheel for low sound and high efficiency. Units feature a lighted grille and are ideal for residential, multi-family or hotel applications.

- Compact size for height restricted areas
- Round standard outlet for quick, easy connections
- Integral damper prevents unwanted backdrafts
- Speed controllable
- Designer grille included

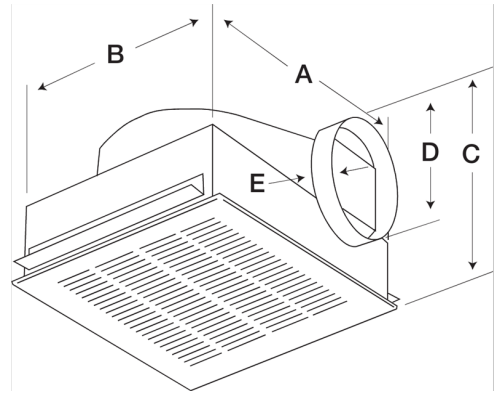

### Performance Characteristics

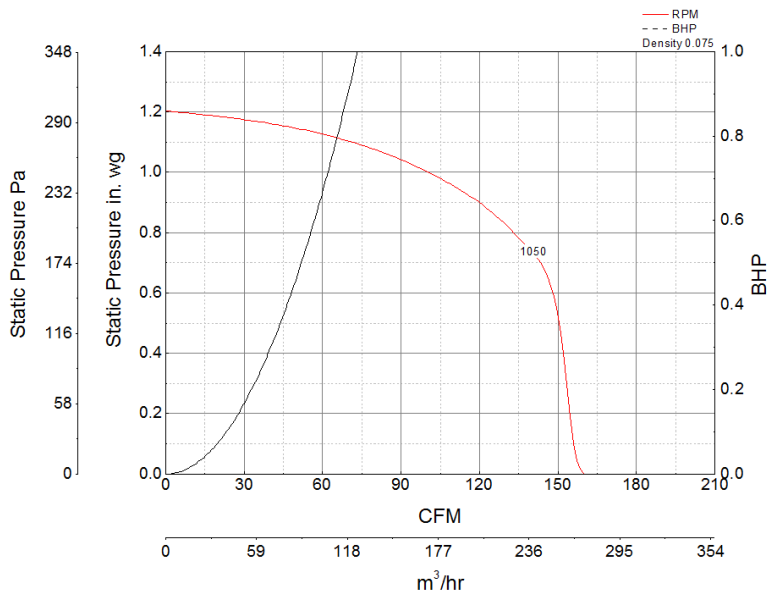

- Greenheck Fan Corporation certifies that the SP models shown herein are licensed to bear the AMCA seal.
- The ratings shown are based on tests and procedures performed in accordance with AMCA Publication 211 and AMCA Publication 311 and comply with the requirements of the AMCA Certified Ratings Program.
- The SP models are not AMCA certified with 50 hertz motors.