



SKU
SP-110-VG-QD

Job Name:
Mark:
Submitted By:
Date: 05/21/2026

Bathroom Exhaust Fan, Product # SP-110-VG-QD



Model SP-VG, bathroom exhaust fan features EC motor technology, allowing for increased energy savings. Units operate at a constant CFM up to 0.25 in. wg. And provide continuous or intermittent ventilation while maintaining extremely low sound levels.

- ENERGY STAR rated
- EC motor
- Designer grille included

Certifications

AMCA Air & Sound
UL/cUL 507

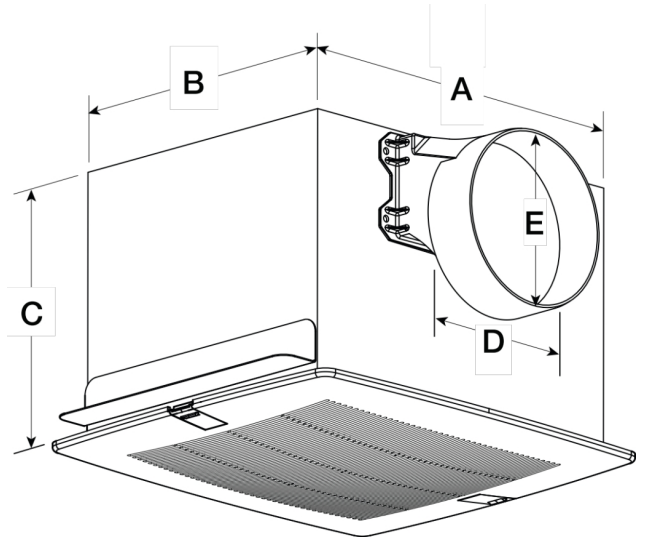

A	B	C	D	E
11.375 in	10.5 in	7.625 in	6 in	6 in

Performance Characteristics

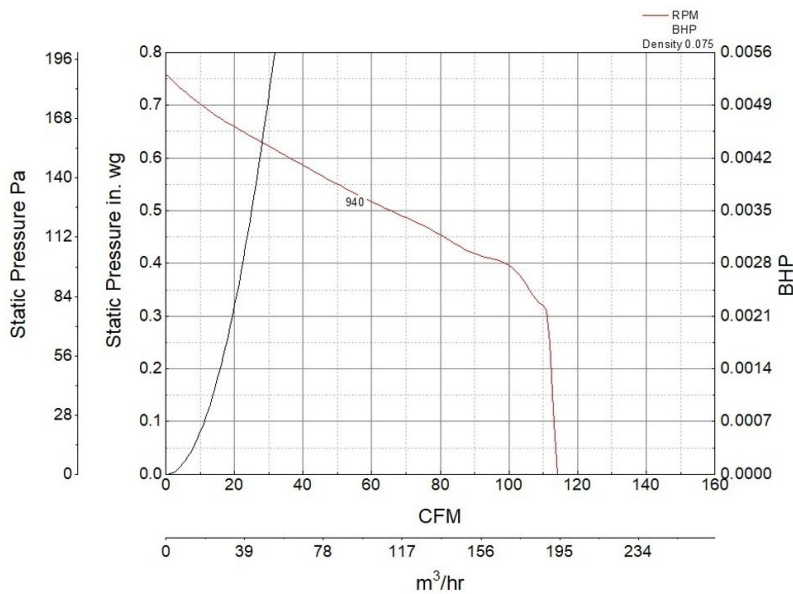

Construction Features

Housing Material	Galvanized Steel
Drive Type	Direct Drive
Impeller Type	Centrifugal Wheel
Impeller Material	Polypropylene
Includes	Backdraft damper EC motor. Mounting brackets
Certifications	AMCA Air & Sound UL/cUL 507
Speed Controllable	Yes

Motor Information

Motor Phase	1
Voltage	115
Watts	8.4

Air and Sound Performance

Watts	Max Fan RPM	Min Fan RPM	Ps (in. wg)	0	0.125	0.25	0.375	0.5	0.625
			CFM	110	110	109	100	62	28
			Sones	<0.3	<0.3	1.4	2.3	3	3.6



- Greenheck Fan Corporation certifies that the SP models shown herein are licensed to bear the AMCA seal.
- The ratings shown are based on tests and procedures performed in accordance with AMCA Publication 211 and AMCA Publication 311 and comply with the requirements of the AMCA Certified Ratings Program.
- The SP models are not AMCA certified with 50 hertz motors.

California Residents

 **WARNING**

This product can expose you to chemicals including cadmium used in the processing of corrosion resistant metal and fasteners, which is known to the State of California to cause cancer and birth defects or other reproductive harm. For more information visit www.P65Warnings.ca.gov