

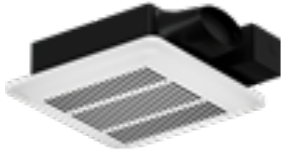

SKU
SP-LP0511H

Job Name:
Mark:
Submitted By:
Date: 04/09/2026

MultiSPEC SP-LP0511H Low-Profile Exhaust Fan with Humidity Sensor



- ENERGY STAR rated
- Virtually silent EC motor with 3 high speeds (50-80-110 CFM)
- Constant CFM technology
- 3-1/2 Inch Housing Depth – the low profile is ideal for wall or ceiling installations. Easily fits in a 2x4 stud bay
- Integrated humidity sensor that helps control bathroom condensation to prevent mold and mildew
- 3-year warranty on EC motor and parts, excluding light
- UL listed for tub/shower enclosure when GFCI protected

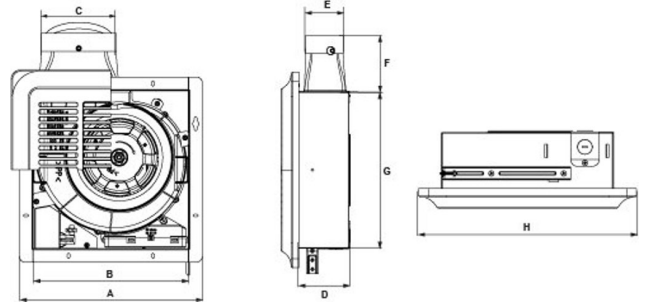

A	B	C	D	E	F	G	H
12.125 in	10.25 in	5 in	3.5 in	2.5 in	3.75 in	10.375 in	13 in

Certifications

UL/cUL 507
Home Ventilating Institute (HVI)

Performance Characteristics

No Fan Curve Available.

Construction Features

Drive Type	Direct Drive
Impeller Type	Centrifugal Wheel
Impeller Material	Polypropylene
Includes	Backdraft damper Mounting brackets
Certifications	UL/cUL 507 Home Ventilating Institute (HVI)
Speed Controllable	Yes

Motor Information

Motor Phase	1
Voltage	115
Hertz	60
Watts	22.7

Air and Sound Performance

Watts	Max Fan RPM	Min Fan RPM	Ps (in. wg)	0.1	0.25	0.4	0.5
14.7	726	0	CFM	50	50	50	50
			Sones	>0.3	0.7	1.5	2.5
			CFM	80	80	80	80
17.7	802	0	Sones	0.8	1.3	2	2.5
			CFM	110	110	110	110
			Sones	1.5	2	3	3

California Residents

 **WARNING**

This product can expose you to chemicals including cadmium used in the processing of corrosion resistant metal and fasteners, which is known to the State of California to cause cancer and birth defects or other reproductive harm. For more information visit www.P65Warnings.ca.gov