



SKU
SP-B110ES-QD

Job Name:
Mark:
Submitted By:
Date: 04/05/2026

Bathroom Exhaust Fan, Product # SP-B110ES-QD, 37-130 CFM



Low profile bathroom exhaust fan, Model SP-B features a forward-curved wheel for low sound and high efficiency. Units are ideal for residential, multi-family or hotel applications.

- ENERGY STAR rated
- Compact size for height restricted areas
- Integral damper prevents unwanted backdrafts
- Round standard outlet for quick, easy connections
- Speed controllable
- Designer grille included
- Motion and humidity sensing grille options available

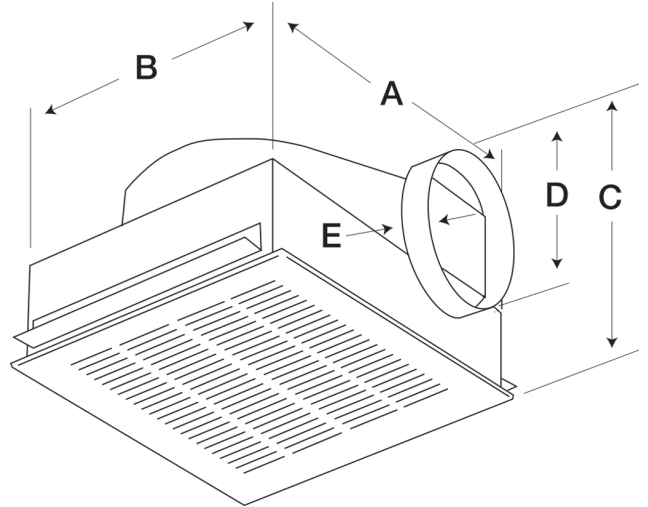

A	B	C	D	E
13.875 in	11.5 in	7 in	6 in	1.25 in

Certifications

AMCA Air & Sound
UL/cUL 507
ENERGY STAR® Certified

Performance Characteristics

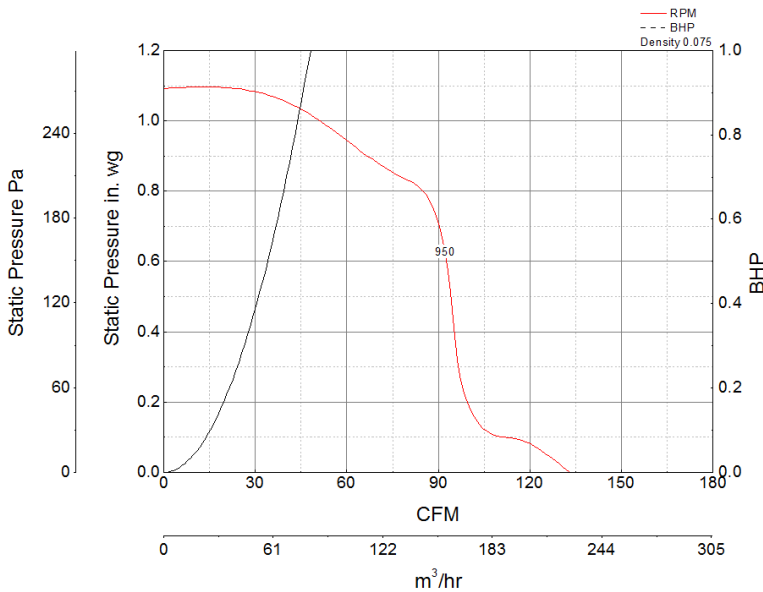

Construction Features

Housing Material	Galvanized Steel
Drive Type	Direct Drive
Impeller Type	Centrifugal Wheel
Impeller Material	Polypropylene
Includes	Backdraft damper Mounting brackets
Certifications	AMCA Air & Sound UL/cUL 507 ENERGY STAR® Certified
Speed Controllable	Yes

Motor Information

Motor Insulation	B
Motor Phase	1
Motor Type	Shaded Pole
Service Factor	1
Voltage	115
Hertz	60
Motor Enclosure	n/a
RPM	950
Thermal Protection	AutoOverload
Nominal Efficiency	12
Watts	8

Air and Sound Performance

Watts	Max Fan RPM	Min Fan RPM	Ps (in. wg)	0	0.1	0.125	0.25	0.375	0.5	0.625	0.75
30	650	520	CFM	130	118	115	100	86	73	58	37
			Sones	1.5	1.5	1.5	2	2.5	3	3.5	4

California Residents

 **WARNING**

This product can expose you to chemicals including cadmium used in the processing of corrosion resistant metal and fasteners, which is known to the State of California to cause cancer and birth defects or other reproductive harm. For more information visit www.P65Warnings.ca.gov