



SKU  
CRD2-8

Job Name:  
Mark:  
Submitted By:  
Date: 05/27/2026

## Round Ceiling Radiation Damper, 165° Fusible Link, Product # CRD2-8



Ceiling radiation dampers are designed to protect penetrations through the ceiling membrane of fire resistive floor ceiling and/or roof ceiling assemblies. These products are tested and listed in accordance with UL Standard 555C.

- UL tested and labeled for protection of ceiling openings in fire-rate floor/ceiling assemblies with fire resistance ratings of 3 hours or less
- Diameter furnished approximately 0.25 in. under size

### Certifications

California State Fire Marshal (Listing # 3225-0981:0101)

UL 555C (Listing # R13446)

NFPA Standards 90A and 101

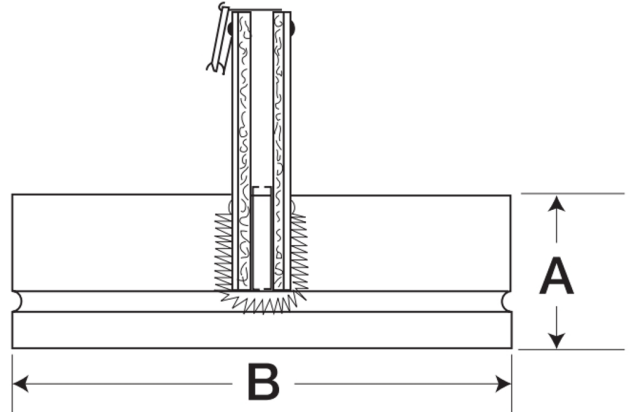

A	B
3.4688 in	8 in

### Performance Characteristics

No Fan Curve Available.

### Construction Features

Blade Style	Butterfly
Closure Type	Fusible link
Frame Material	Galvanized Steel
Blade Material	Galvanized Steel
Certifications	California State Fire Marshal (Listing # 3225-0981:0101) UL 555C (Listing # R13446) NFPA Standards 90A and 101

### California Residents

#### WARNING

This product can expose you to chemicals including cadmium used in the processing of corrosion resistant metal and fasteners, which is known to the State of California to cause cancer and birth defects or other reproductive harm. For more information visit [www.P65Warnings.ca.gov](http://www.P65Warnings.ca.gov)