



**MODEL NYD, NYB
Tamper Resistant
Centrifugal Roof Exhaust Fans**

Installation, Operation and Maintenance Manual

Upon receiving unit, check for any damage and report it immediately to the shipper. Also check to see that all accessory items are accounted for.

Move fan to desired location and fasten securely through mounting holes in base. Shims may be necessary depending upon roofing material thickness. The following diagrams depict dimensions for the NYD and NYB.

A heavy gauge stainless steel hasp allows the unit to be padlocked for security. The hasp design conceals the padlock beneath the housing skirt, which keeps it out of sight and the weather.

The motor's amperage and voltage ratings must be checked for compatibility to supply voltage prior to final electrical connection. Electrical lead-in wires should be run through the conduit provided between the curb and the bottom of the motor compartment. Wiring must conform to local and national codes.

MODEL NYD

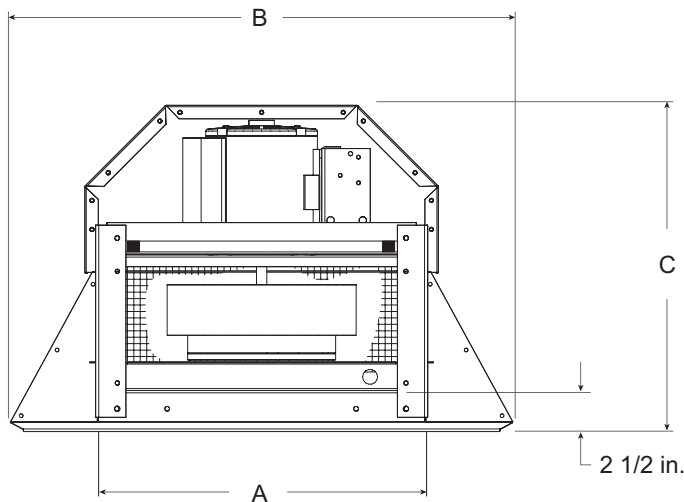

Model	A	B	C	Damper Size	Roof Opening	Approx. Weight
NYD-75	19	30 3/4	20 1/2	10x10	12 1/2	62
NYD-90	19	30 3/4	20 1/2	10x10	12 1/2	75
NYD-100	22	35 1/2	25	12x12	14 1/2	95
NYD-120	24	37	23 1/8	14x14	16 1/2	95
NYD-130	24	37	23 1/8	14x14	16 1/2	105
NYD-140	26	41 1/2	26 7/8	16x16	18 1/2	113

MODEL NYB

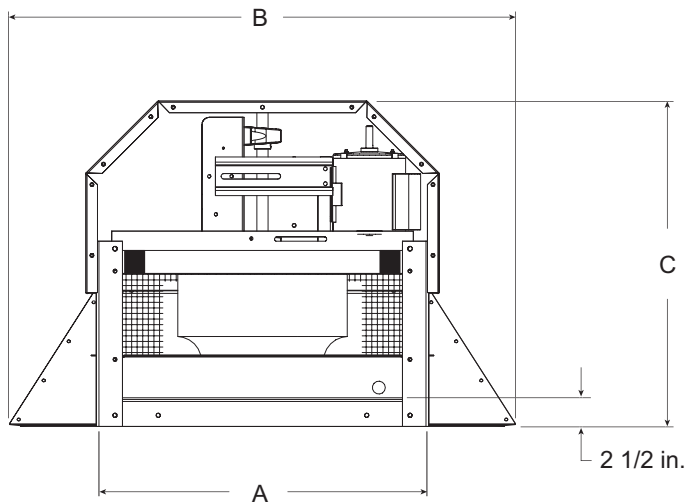

Model	A	B	C	Damper Size	Roof Opening	Approx. Weight
NYB-100	22	35 1/2	25	12x12	14 1/2	93
NYB-140	26	41 1/2	26 7/8	16x16	18 1/2	135
NYB-180	30	45	32 5/8	18x18	20 1/2	225
NYB-240	34	52 1/2	38 5/8	24x24	26 1/2	314

PRE-STARTING CHECKS

Check all fasteners for tightness. The wheel should rotate freely and be aligned as shown in Fig. 3. Wheel position is preset and the unit is test run at the factory. Movement may occur during shipment, and realignment may be necessary. Centering can be accomplished by loosening the bolts holding the drive frame to the shock mounts and repositioning the drive frame. Wheel and inlet cone overlap can be adjusted by loosening the set screws in the wheel and moving the wheel to the desired position.

Direction of wheel rotation is critical. Reversed rotation will result in poor air performance, motor overloading and possible burnout. Check wheel rotation by momentarily energizing the unit. Rotation should be clockwise as shown in Fig. 4 and correspond to the rotation decal on the unit. Rotation is determined when the unit is viewed from the motor or shaft pulley side.

Belt tension can be adjusted by loosening four fasteners (marked "R" in Fig. 5) on the drive frame. This allows the motor plate to slide on the drive frame angles for proper positioning. Belt tension should be adjusted to allow 1/64 in. of deflection per inch of belt span. For example, a 15 in. belt span should have 15/64 in. (or about 1/4 in.) of deflection with moderate thumb pressure at mid-point between pulleys (see Fig. 6). Over tightening will cause excessive bearing wear and noise. Too little tension will cause slippage at startup and uneven wear.

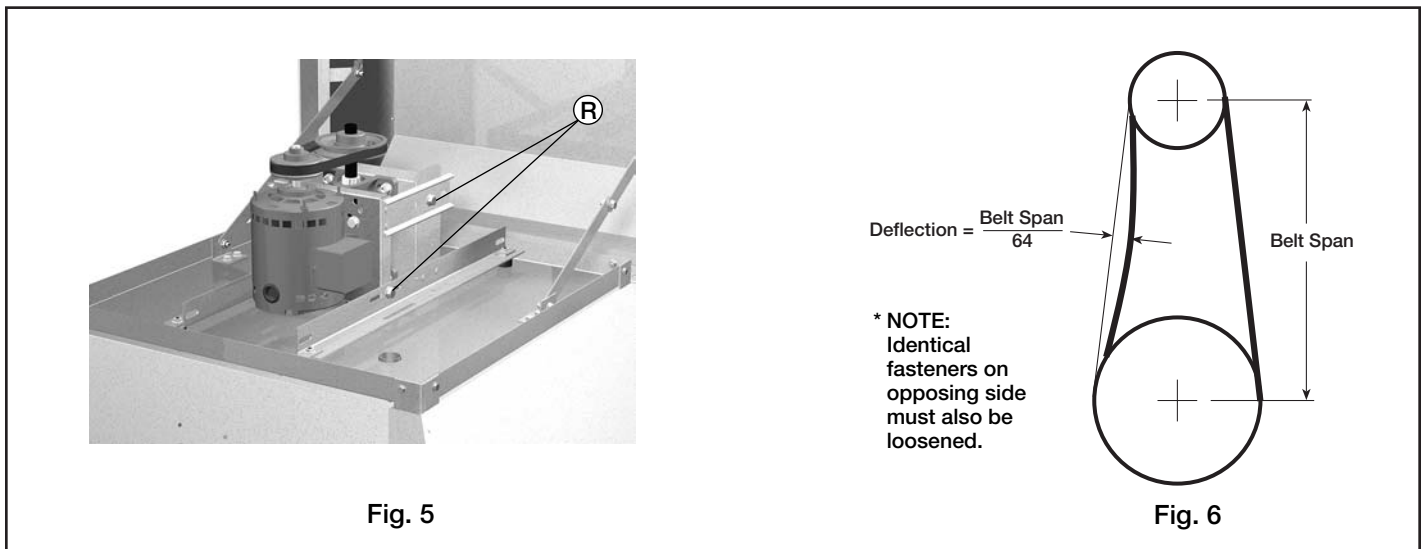
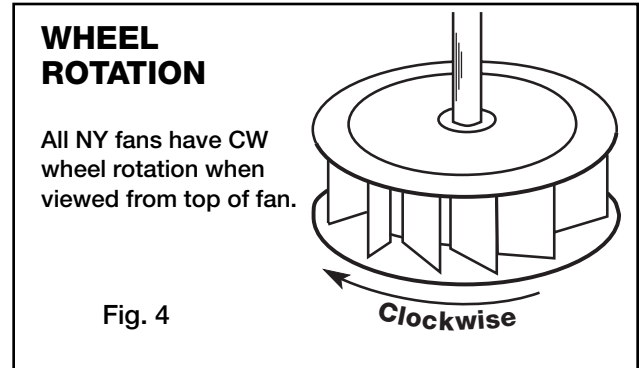
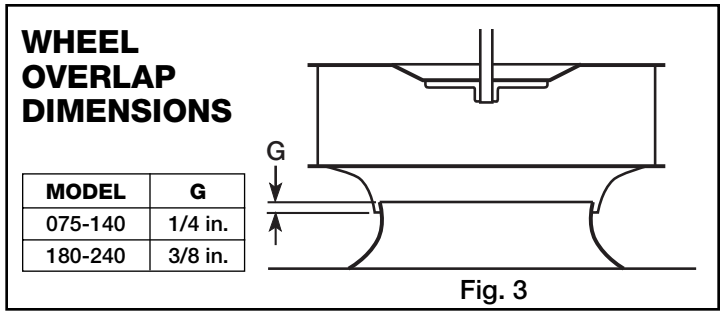

If adjustments are made, it is very important to check the pulleys for proper alignment. Misaligned pulleys lead to excessive belt wear, vibration, noise and power loss (see Fig. 7).

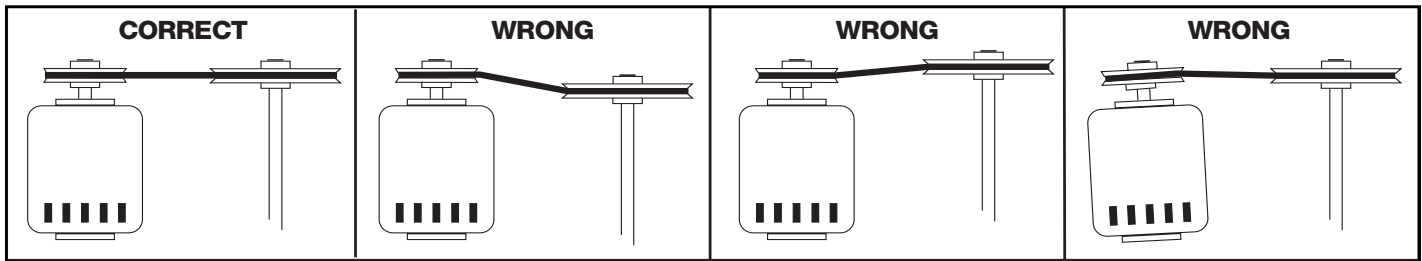

The adjustable motor pulley is factory set for the RPM specified. Speed can be increased by closing or decreased by opening the adjustable motor sheave. Two groove variable pitch pulleys must be adjusted an equal number of turns open or closed. Any increase in speed represents a substantial increase in the horsepower required by a unit. Motor amperage should always be checked to avoid serious damage to the motor when speed is varied.

MAINTENANCE

Belts tend to stretch after a period of time. They should be checked periodically for wear and tightness. When replacing belts, use the same type as supplied with the unit. Matched belts should always be used on units with multigroove pulleys. For belt replacement, loosen the tensioning device far enough to allow removal of the belt by hand. Do not force belts on or off. This may cause cords to break, leading to premature belt failure. Once installed, adjust belts as shown in "Pre-Starting Checks."

Shaft bearings can be classified in two groups: relubricating and non-relubricating. All bearings are factory lubricated and require no further lubrication under normal use (between -20°F and 180°F in a relatively clean environment). Units installed in hot, humid or dirty locations should be equipped with special bearings. These bearings will require frequent lubrication. Caution should be employed to prevent overpacking or contamination. Grease fittings should be wiped clean. The unit should be in operation while lubricating. Extreme care should be used around moving parts. Grease should be pumped in very slowly until a slight bead forms around the seal. A high grade lithium base grease is recommended.

Motor maintenance is generally limited to cleaning and lubrication (where applicable). Cleaning should be limited to exterior surfaces only. Removing dust buildup on motor housing ensures proper motor cooling. Greasing of motors is only intended when fittings are provided. Many fractional hp motors are permanently lubricated and should not be lubricated further. Motors supplied with grease fittings should be greased in accordance with manufacturers' recommendations. Where motor temperatures do not exceed 104°F (40°C), the grease should be replaced after 2000 hours of running time as a general rule.

Wheels require very little attention when moving clean air. Occasionally, oil and dust may accumulate causing imbalance. When this occurs, the wheel and housing should be cleaned to ensure smooth and safe operation.

Direct drive units require little maintenance except for cleaning wheel alignment and oiling according to motor label instructions.

The unit should be made non-functional when cleaning the wheel or housing (fuses removed, disconnect locked off, etc.).

All fasteners should be checked for tightness each time maintenance checks are performed prior to restarting unit.

A proper maintenance program will help these units deliver years of dependable service.

TROUBLESHOOTING

PROBLEM	CAUSE	CORRECTIVE ACTION
REDUCED AIR FLOW	System resistance too high.	Check system: Proper operation of backdraft or control dampers, obstruction in ductwork, etc.
	Unit running backwards.	Correct as shown in Fig. 4.
	Excessive dirt buildup on wheels.	Clean wheel.
	Improper wheel alignment.	Center wheel on inlets.
EXCESSIVE NOISE OR VIBRATION	Bad bearings.	Replace.
	Belts too tight or too loose.	Refer to Fig. 8 and adjust tension.
	Wheel improperly aligned and rubbing.	Center wheel on inlets (see Fig. 3).
	Loose drive or motor pulleys.	Align and tighten. See "Pre-Starting Checks."
	Foreign objects in wheel or housing.	Remove objects, check for damage or unbalance.
	Unbalance of wheel caused by excessive dirt and grease buildup.	Remove buildup.

NOTE: Before taking any corrective action, make certain unit is not capable of operation during repairs.

PARTS LIST

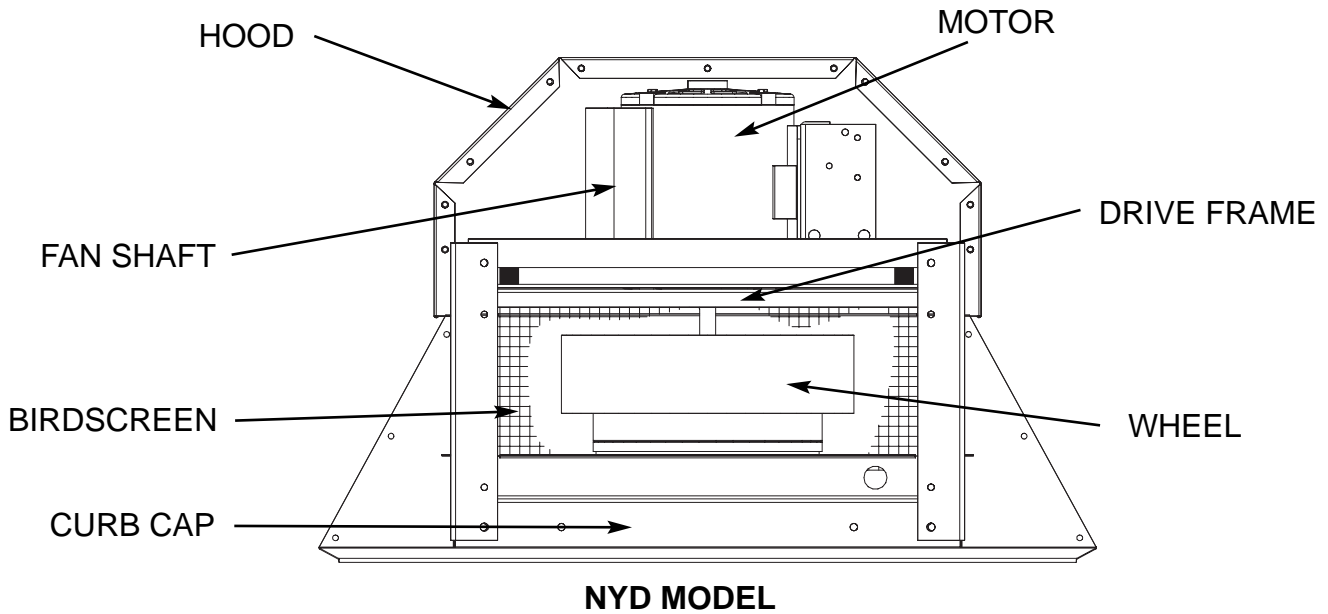

NYD MODEL

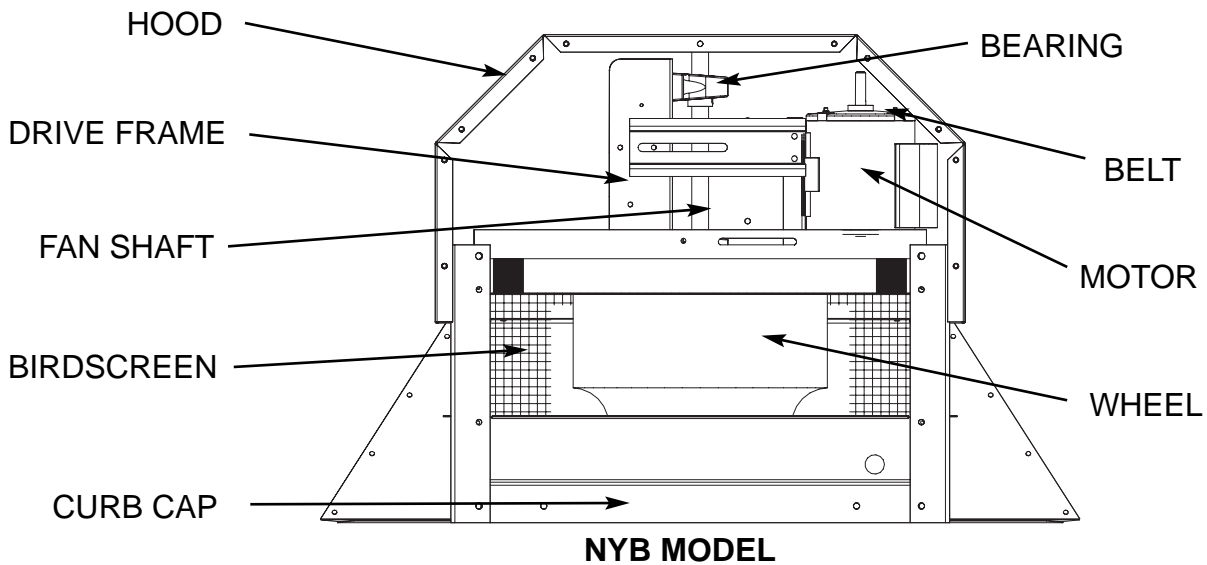

NYB MODEL

NOTE: Each fan bears a manufacturer's nameplate with model number and serial number embossed. This information will assist the local Greenheck representative and the factory in providing service and replacement parts.

Warranty

Greenheck warrants this equipment to be free from defects in material and workmanship for a period of one year from the purchase date. Any units or parts which prove defective during the warranty period will be replaced at our option when returned to our factory, transportation prepaid.

Motors are warranted by the motor manufacturer for a period of one year. Should motors furnished by Greenheck prove defective during this period, they should be returned to the nearest authorized motor service station. Greenheck will not be responsible for any removal or installation costs.



IOM NYD/NYB FS
Rev. 1 MAY 2003