

Two-Position, Oil-Submerged Actuators

These actuators provide two-position operation of dampers, valves, and other equipment requiring the return to normal position upon power interruption.

Features:

- SPST controller.
- Spring return.
- 24, 120, 208, and 240 Vac models.
- SPDT auxiliary switch if actuator part number suffix is "-500."
- Rugged die cast aluminum.
- Oil immersed motor and gear train.
- Models for hazardous locations are only available as a factory enclosure/actuator assemblies.
- NEMA 4 with optional watertight conduit connectors, field supplied.

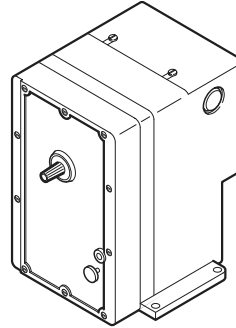

MA-3xx, MA5-318,
MA-4xx, MA5-418
(Standard)

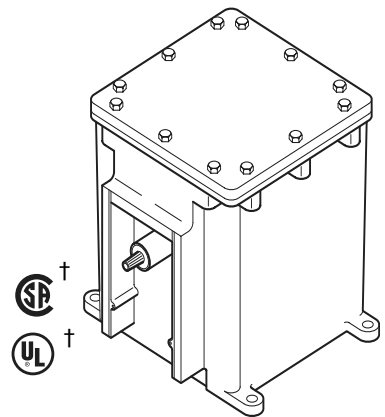

MA6-3xx, MA8-3xx,
MA6-4xx, MA8-4xx, MA7-4xx
† Hazardous Locations

Model Chart								
Model No.	Power Supply		Aux. ^a Switch	Input (Watts)	Va Running/Holding	Rated Torque lb-in. (N-m)	Application and Mounting	Shaft Rotation
	Vac	Hz						
MA-305	24	60	No	25	56/56	16 (1.8)	Damper actuators. Upright position preferred.	CW 180° when power is applied.
MA-305-500	24		Yes					
MA-405	120		No					
MA-405-500	120		Yes					
MA-318	24		No	70 Running 25 Holding	92/32	60 (6.8)	Damper and valve actuators. Output shaft horizontal.	CW 170° when power is applied.
MA-318-500	24		Yes					
MA-416	208		No					
-								
MA-418	120		No					
MA-418-500	120		Yes					
MA-419	240		No					
MA-419-500	240		Yes					
MA5-419	240		50	No	120/39			
MA5-419-500	240			Yes				

^a 2 FLA, 12 LRA at 24/120 Vac; 1 FLA, 6 LRA 2 240 Vac.

† Models for hazardous locations are only available as factory enclosure/actuator assemblies.

MA-3XX Series, MA-4XX Series

Part Numbers for Hazardous Location Applications^{a b}.

Model No.	Damper Actuator Part Numbers for Hazardous Locations	Valve Actuator Part Numbers for Hazardous Locations
MA-305	MA6-305	—
MA-305-500	MA6-305-500	—
MA-405	MA6-405	—
MA-405-500	MA6-405-500	—
MA-318	MA6-318	MA8-318
MA-318-500	MA6-318-500	MA8-318-500
MA-416	MA6-416	MA8-416
-		
MA-418	MA6-418	MA8-418
MA-418-500	MA6-418-500	MA8-418-500
MA-419	MA6-419	MA8-419
MA-419-500	MA6-419-500	MA8-419-500
MA5-419	MA7-419	MA7-419
MA5-419-500	MA7-419-500	MA7-419-500

^a Class 1, Groups C and D, and Class 2, Groups E, F and G, hazardous locations. Ref. EN-56-2, F-18451.

^b Models for hazardous locations are only available as factory enclosure/actuator assemblies.

Specifications

Control circuit	Two wire.
Spring return	CCW to original position when actuator is de-energized.
Auxiliary switch (-500 models)	SPDT makes (or breaks) circuit at powered end of stroke (fixed).
Nominal damper area	Actuator sizing should be done in accordance with damper manufacturer's specifications.
Environment	
Ambient temperature limits	Shipping and storage: -40 to 136°F (-40 to 58°C). Operating: -40 to 136° (-40 to 58°C).
Humidity	5 to 95% RH, non-condensing.
Locations	NEMA 4 ^a .
Connections	Coded screw terminals.
Case	Die cast aluminum with two 1/2 in. conduit openings.
Mounting	Allow 6 in. (152 mm) clearance above the actuator wiring compartment. Refer to Model Chart for additional data.
Dimensions	
Base actuators	5-3/4 H x 5-3/8 W x 6-9/16 D in. (146 x 136 x 167 mm).
Hazardous location actuators	8-7/8 H x 8-1/2 W x 10-5/8 D in. (225 x 216 x 167 mm).
No load timing^b at 75°F (24°C)	20 seconds.
Agency Listings	
UL 873	File E9429 Temperature Indicating and Regulating Equipment.
CSA	C22.2 No. 24 File LR 3728.
General Instructions	Refer to F-06491.

^a When used with gasket (provided) and water-tight conduit connectors (not provided).

^b Spring return timing with full load opposing spring approximately 60 seconds.

Accessories

Model No.	Description
Damper linkage.	
AM-111	Crank arm for 5/16 in. diameter damper shaft.
AM-112	Crank arm for 3/8 in. diameter damper shaft.
AM-113	Crank arm for actuator or 1/2 in. diameter damper shaft.
AM-115	Crank arm for 7/16 in. diameter damper shaft.
AM-116	Splined crank arm for actuator.
AM-122	Linkage connector straight type.
AM-123	Damper clip.
AM-125	5/16 in. diameter x 20 in. damper rod.
AM-125-048	5/16 in. diameter x 48 in. damper rod.
AM-132	Ball joint connector.
AM-161	Damper linkage kit.
AM-161-1	Damper linkage kit.
AM-301	90 degree mounting bracket (except MA6, MA7, MA8-xxx).
Valve linkage for 60 lb-in. (6.8 N-m) actuators only (except MA7, MA8-xxx).	
AV-29 and AV-300	2-1/2 and 3 in. VB-9323.
AV-391	1/2 to 2 in. VB-7xxx and 1/2 to 1-1/4 in. discontinued VB-9xxx.
AV-392	1-1/2 and 2 in. VB-92X3 or VB-93X3.
AV-395	2-1/2 to 4 in. VB-92X3 or VB-9313.
Valve Only (To be used with 60 lb-in. (6.8 N-m) MA7-xxx and MA8-xxx hazardous location actuators only)	
NYBA-37	Stem extension for 1/2 to 2 in. VB-7xxx and 1/2 to 1-1/4 in. discontinued VB-9xxx, for actuators assembled in hazardous locations enclosure (use with AV-391 linkage kit).
NYBA-61	Mounting bracket for hazardous locations enclosure (use with AV-391 linkage kit).

Typical Applications

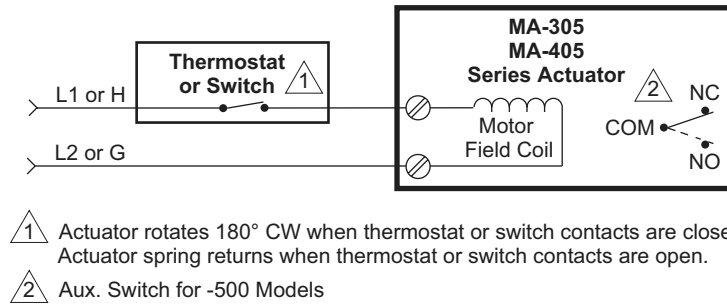

Figure 1 Wiring for MA-305 and 405 Series.

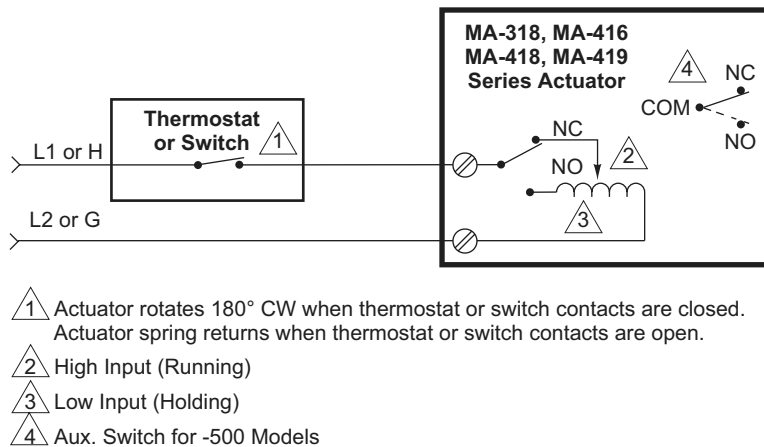

Figure 2 Wiring for MA-318, 416, 418, and 419 Series.