

Application and Design

The VCD-M20 series is a ruggedly built general purpose damper for application as an automatic control or manual balancing damper. A wide range of electric and pneumatic actuators are available. The VCD-M20 is intended for application in low to medium pressure and velocity systems.

Ratings (See page 4 for specific limitations)

Pressure: 622 Pa - 1245 Pa (2.5 - 5.0 in. wg) - pressure differential.

Velocity: 10.2 m/s - 15.2 m/s (2000 to 3000 fpm)

Temperature: 82°C (180°F)

Standard Construction

Frame: 127mm x 25mm (5 in. x 1 in.) 1.5mm (16ga.) galvanized steel hat channel. Reinforced corners. Low profile head and sill are used on sizes less than 432mm (17 in.).

Blades: 1.5mm (16 ga.) galvanized steel, reinforced with 3 longitudinal structurally designed vee's.

Linkage: Side linkage out of airstream (concealed in frame).

Axles: 13mm (1/2 in.) dia. plated steel. Removable control shaft extends 152mm (6 in.) beyond frame.

Bearings: Synthetic (acetal) sleeve type.

Size Limitations

Minimum Size: 203mm x 152mm
(8 in. x 6 in.)

Maximum Size: Single Section 1219mm x 1880mm
(48 in. W x 74 in. H)
Multiple section 3658mm x 3658mm
(144 in. W x 144 in. H)

Features Available:

- Wide range of electric and pneumatic actuators available
- Sleeve with Integral flange on both side available



Greenheck Kunshan Co. Ltd. and Greenheck Fan Corporation certifies that the model VCD-M20 shown herein is licensed to bear the AMCA Seal. The ratings shown are based on tests and procedures performed in accordance with AMCA Publication 511 and comply with the requirements of the AMCA Certified Ratings Programs. The AMCA Certified Ratings Seal applies to air performance ratings only.

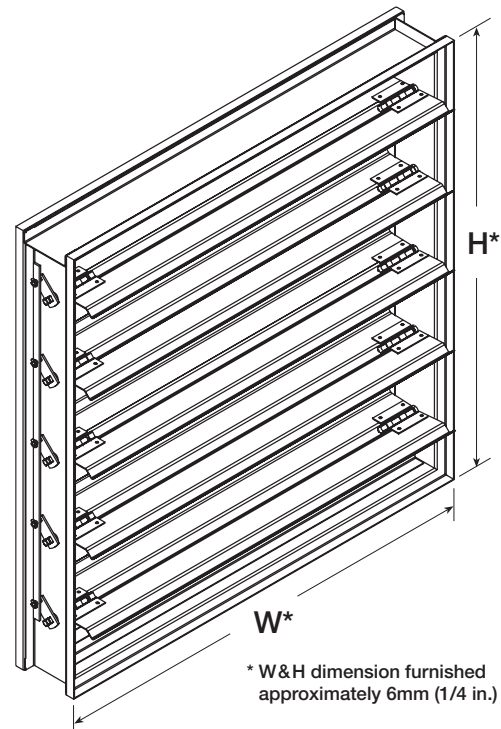

* W & H dimension furnished approximately 6mm (1/4 in.) undersize.

Blade Operation

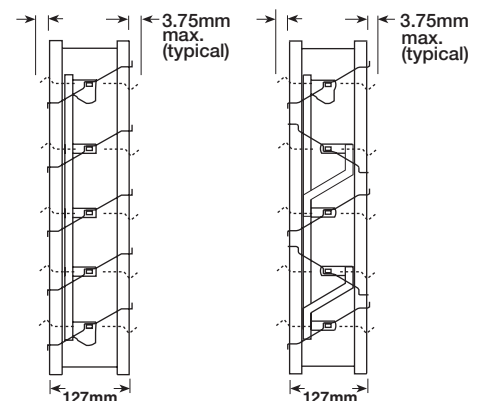

Parallel Blades

Opposed Blades

This pressure drop testing was conducted in accordance with AMCA Standard 500-D using the three configurations shown. All data has been corrected to represent standard air at a density of 1.201 kg/m³.

Actual pressure drop found in any HVAC system is a combination of many factors. This pressure drop information along with an analysis of other system influences should be used to estimate actual pressure losses for a damper installed in a given HVAC system.

AMCA Test Figures

Figure 5.3 Illustrates a fully ducted damper. This configuration has the lowest pressure drop of the three test configurations because entrance and exit losses are minimized by straight duct runs upstream and downstream of the damper.

Figure 5.2 Illustrates a ducted damper exhausting air into an open area. This configuration has a lower pressure drop than Figure 5.5 because entrance losses are minimized by a straight duct run upstream of the damper.

Figure 5.5 Illustrates a plenum mounted damper. This configuration has the highest pressure drop because of extremely high entrance and exit losses due to the sudden changes of area in the system.

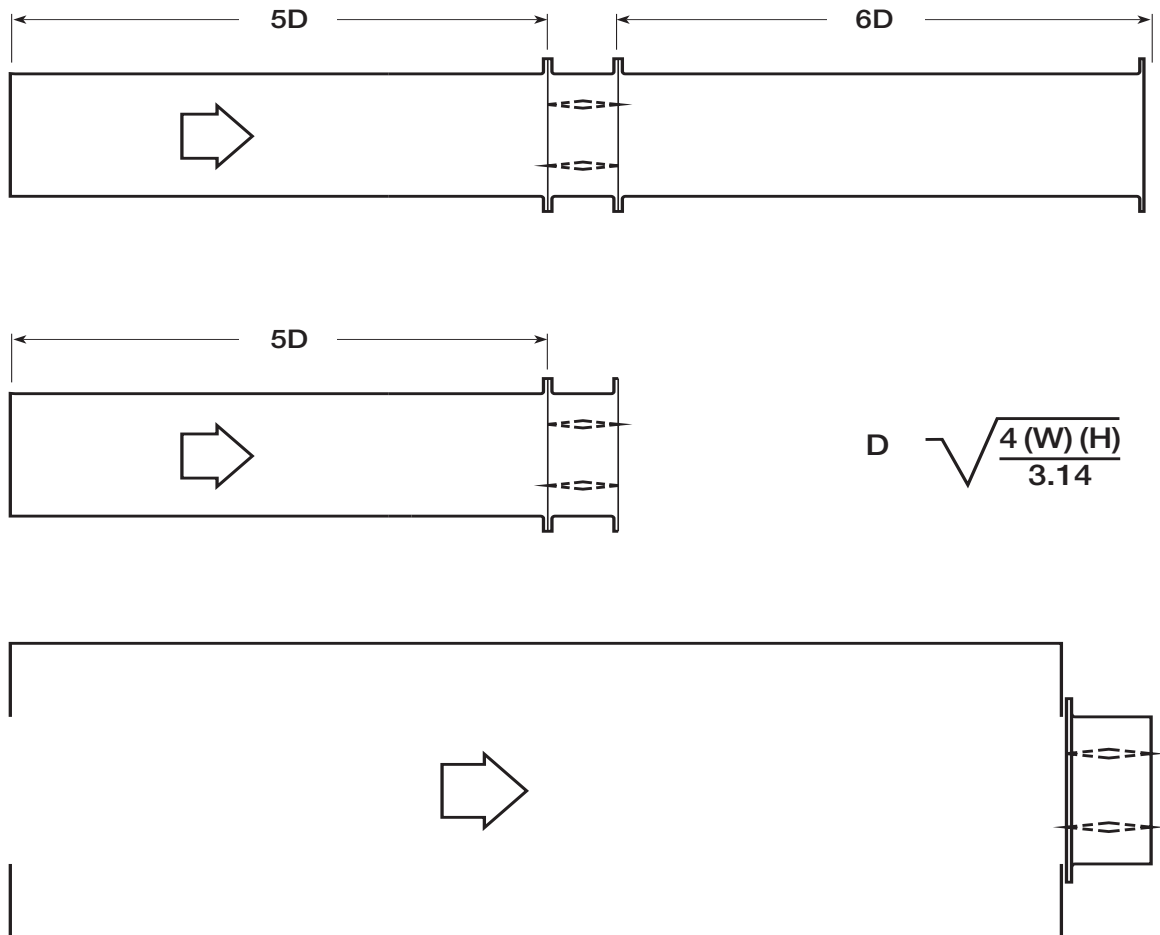

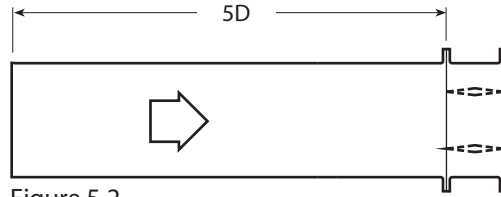
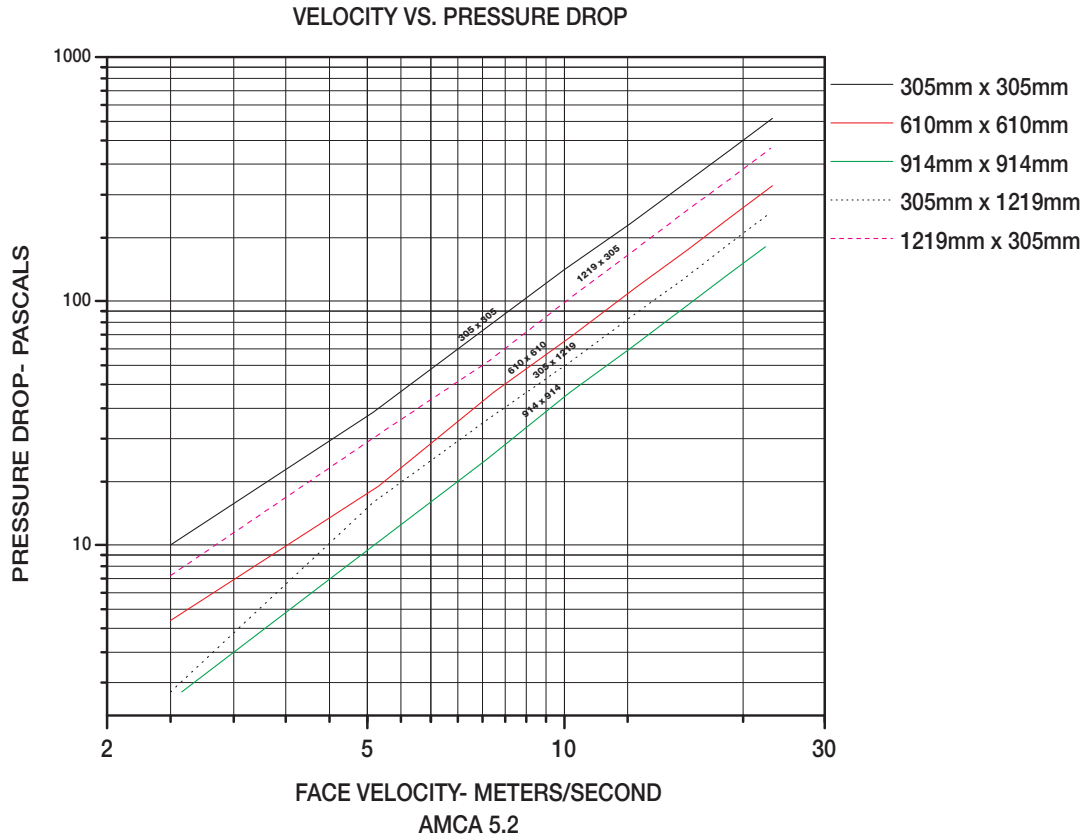

Figure 5.2



305mm x 305mm	
Velocity (m/s)	Pressure Drop (Pa)
2.5	10
5.1	35
7.7	80
10	135
12.6	207
15.5	311
17.8	411
20.8	561

610mm x 610mm	
Velocity (m/s)	Pressure Drop (Pa)
2.5	5
5.2	17
7.8	42
10.3	72
12.9	115
15.4	162
18.1	224
20.8	296

914mm x 914mm	
Velocity (m/s)	Pressure Drop (Pa)
2.6	3
5.1	10
7.6	22
10.2	42
12.7	65
15.3	95
17.7	127
20.3	167

305mm x 1219mm	
Velocity (m/s)	Pressure Drop (Pa)
2.5	3
5.1	15
7.6	32
10.3	57
12.9	90
15.3	125
18	174
20.5	227

1219mm x 305mm	
Velocity (m/s)	Pressure Drop (Pa)
2.5	8
5.1	27
7.7	57
10.3	105
12.9	164
15.6	242
17.9	316
20.7	424



Greenheck Kunshan Co. Ltd. and Greenheck Fan Corporation certifies that the model VCD-M20 shown herein is licensed to bear the AMCA Seal. The ratings shown are based on tests and procedures performed in accordance with AMCA Publication 511 and comply with the requirements of the AMCA Certified Ratings Programs. The AMCA Certified Ratings Seal applies to air performance ratings only.

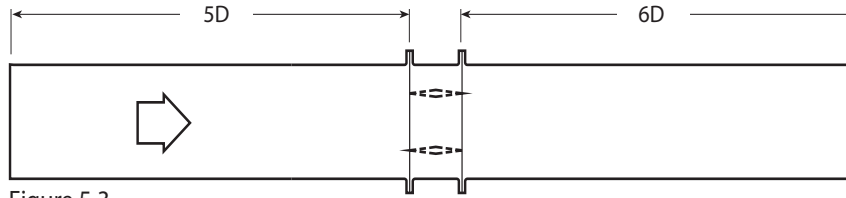
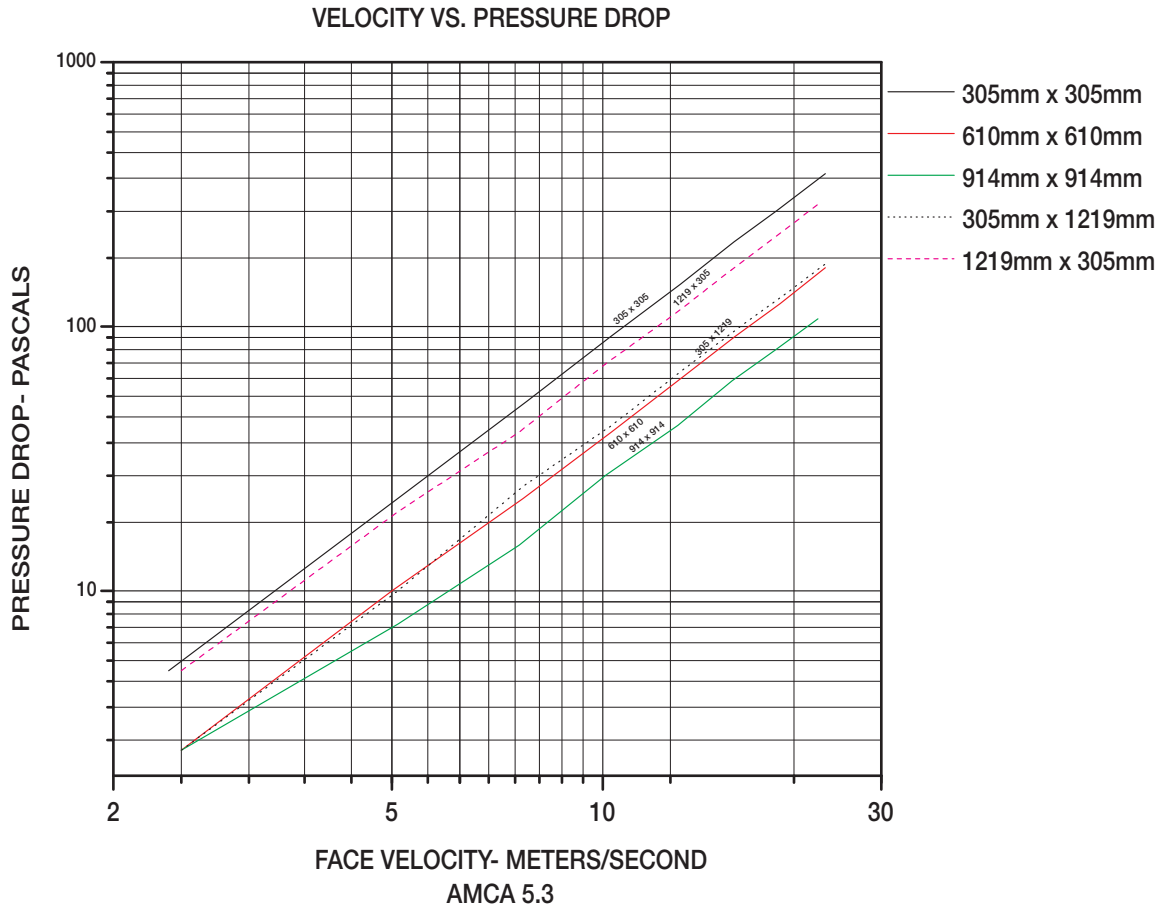

Figure 5.3



305mm x 305mm	
Velocity (m/s)	Pressure Drop (Pa)
2.4	5
5.1	22
7.8	52
10.3	92
12.9	145
15.4	209
17.7	274
20.8	379

610mm x 610mm	
Velocity (m/s)	Pressure Drop (Pa)
2.5	3
5	10
7.7	22
10.3	40
12.8	62
15.5	92
17.9	122
20.8	167

914mm x 914mm	
Velocity (m/s)	Pressure Drop (Pa)
2.5	3
5.1	8
7.6	15
10.1	27
12.8	42
15.3	62
17.7	82
20.3	107

305mm x 1219mm	
Velocity (m/s)	Pressure Drop (Pa)
2.5	3
5.1	10
7.7	25
10.3	42
12.9	67
15.7	100
18.7	140
20.9	174

1219mm x 305mm	
Velocity (m/s)	Pressure Drop (Pa)
2.5	5
5.1	20
7.6	40
10.1	72
12.7	112
15.3	164
18	227
20.6	299



Greenheck Kunshan Co. Ltd. and Greenheck Fan Corporation certifies that the model VCD-M20 shown herein is licensed to bear the AMCA Seal. The ratings shown are based on tests and procedures performed in accordance with AMCA Publication 511 and comply with the requirements of the AMCA Certified Ratings Programs. The AMCA Certified Ratings Seal applies to air performance ratings only.

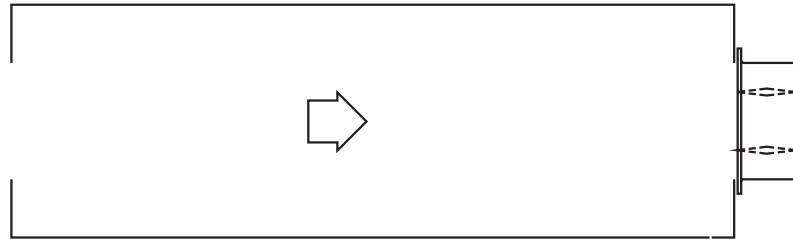

VELOCITY VS. PRESSURE DROP

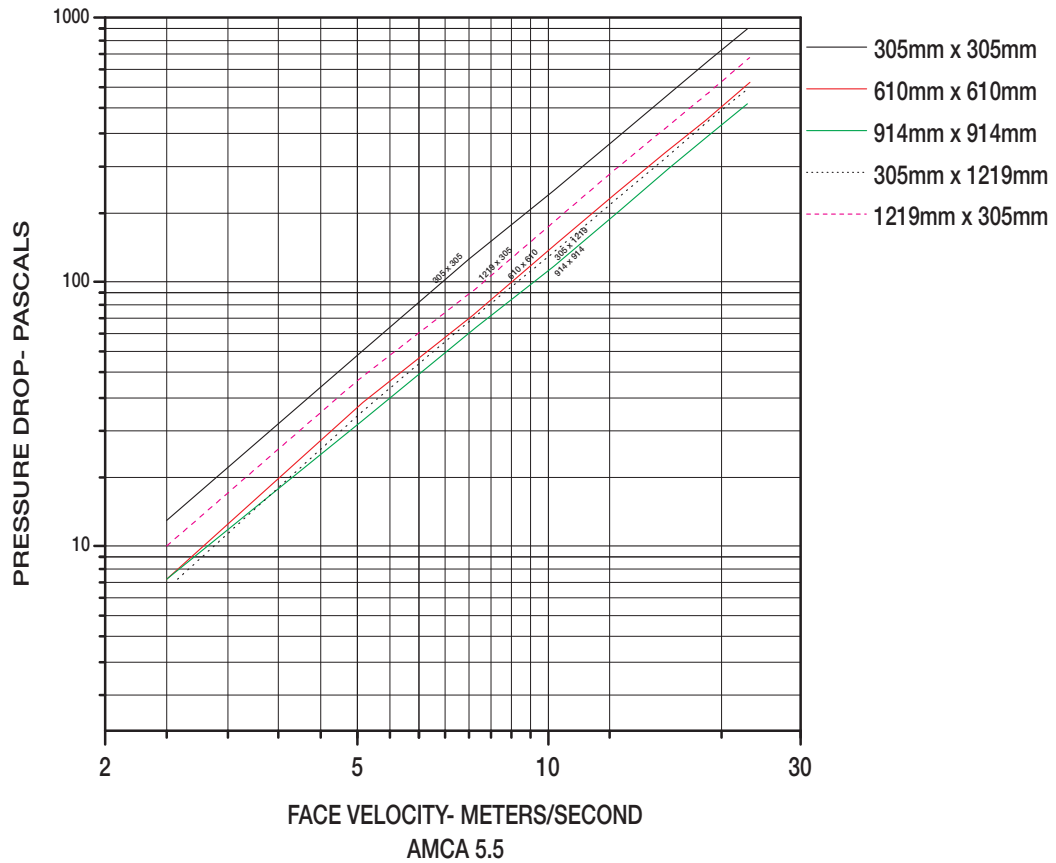

305mm x 305mm	
Velocity (m/s)	Pressure Drop (Pa)
2.5	13
5	55
7.5	122
10.2	222
12.7	349
15.4	508
17.9	688
20.6	907

610mm x 610mm	
Velocity (m/s)	Pressure Drop (Pa)
2.5	8
5	35
7.6	75
10.3	140
12.8	217
15.3	309
17.7	409
20.8	568

914mm x 914mm	
Velocity (m/s)	Pressure Drop (Pa)
2.5	8
5.1	30
7.7	67
10.2	115
12.9	184
15.5	269
18.1	354
20.6	471

305mm x 1219mm	
Velocity (m/s)	Pressure Drop (Pa)
2.6	8
5.1	32
7.7	75
10.2	130
12.7	202
15.5	301
18.1	416
20.6	536

1219mm x 305mm	
Velocity (m/s)	Pressure Drop (Pa)
2.5	1
5	42
7.7	95
10.3	172
12.7	264
15.3	381
17.9	521
20.8	707



Greenheck Kunshan Co. Ltd. and Greenheck Fan Corporation certifies that the model VCD-M20 shown herein is licensed to bear the AMCA Seal. The ratings shown are based on tests and procedures performed in accordance with AMCA Publication 511 and comply with the requirements of the AMCA Certified Ratings Programs. The AMCA Certified Ratings Seal applies to air performance ratings only.

Multi-Section Assembly

Dampers larger than the maximum single section size, will be made up of a multiple of equal size sections. Multiple section dampers can be jackshafted together so that all sections operate together as shown below.

NOTE: Dampers larger than 1219mm x 1880mm (48 in. x 74 in.) are not intended to be structurally self supporting. Additional horizontal bracing is recommended to support the weight of the damper and vertical bracing should be installed as required to hold against system pressure.

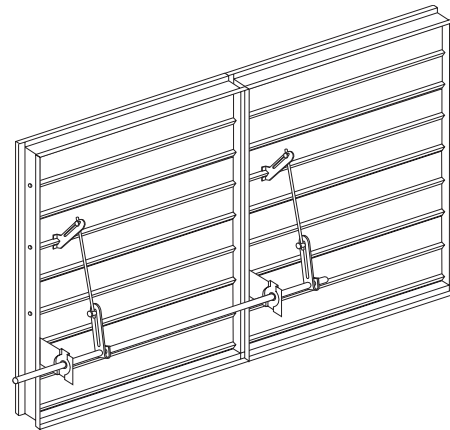

Selection Criteria

Pressure Limitations

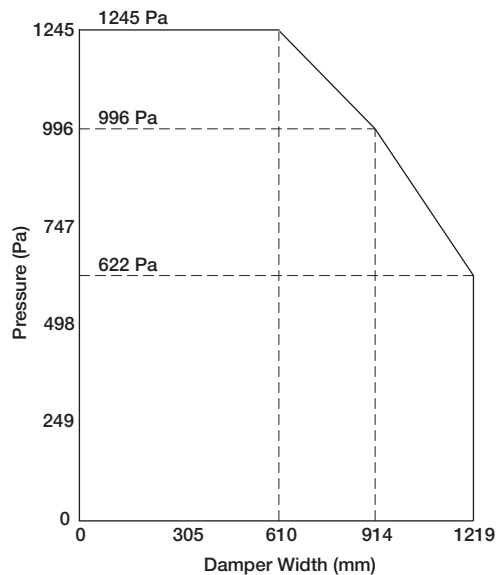

Velocity Limitations

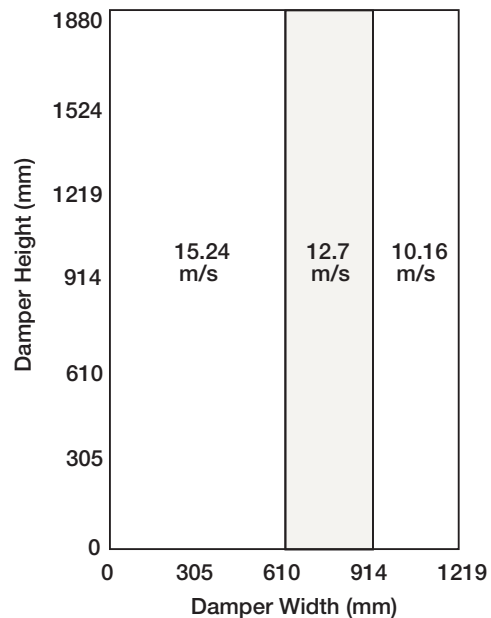

NOTE: VCD-M20 will withstand higher pressures and velocities. Displayed ratings are conservative to prevent misapplication. Consult Greenheck if you have an application outside these limitations.

Temperatures in excess of 82°C (180°F) require special consideration.

Specifications

Control dampers meeting the following specifications shall be furnished and installed where shown on plans and/or as described in schedules.

Damper blades shall be 1.5mm (16 ga.) galvanized steel 3 Vee type with three longitudinal grooves for reinforcement. Blades shall be completely symmetrical relative to their axle pivot point, presenting identical resistance to airflow and operation in either direction through the damper (blades that are non-symmetrical relative to their axle pivot point or utilize blade stops larger than 13mm [½ in.] are unacceptable). Linkage shall be blade-to-blade concealed in jamb (out of the airstream) to protect linkage and reduce pressure drop and noise.

Damper frame shall be 1.5mm (16 ga.) galvanized steel formed into a structural hat channel shape with reinforced corners to meet 3.1mm (11 ga.) criteria. Bearings shall be corrosion resistant, permanently lubricated, synthetic (acetal)

sleeve type rotating in extruded holes in the damper frame for maximum service. Axles shall be square and positively locked into the damper blade.

The Damper Manufacturer's submittal data shall certify all air performance pressure drop data is licensed in accordance with the AMCA Certified Ratings Program for Test Figures 5.2, 5.3 and 5.5. Damper air performance data shall be developed in accordance with the latest edition of AMCA Standard 500-D.

Damper manufacturer's printed application and performance data including pressure, velocity and temperature limitations shall be submitted for approval showing damper suitable for pressures to 1245 Pa (5 in. wg), velocities to 15.2 m/s (3000 fpm) and temperatures to 82°C (180°F). Testing and ratings to be in accordance with AMCA Standard 500. Basis of design is Greenheck model VCD-M20.