

Application and Design

The VCD-40 is an ultra low leakage high performance control damper with extruded aluminum airfoil blades. Blades are completely contained within the frame allowing the damper to be directly mounted to a louver, filter frame or similar application with no blade interference. Smooth profile extruded aluminum airfoil blades insure the lowest resistance to airflow in HVAC systems with velocities to 6000 fpm (30.5 m/s) and pressures to 6 in. wg. (1.5 kPa). VCD-40 is IECC (International Energy Consumption code) compliant with a leakage rating of 3 cfm/ft² @ 1 in. wg (55 cmh/m² @ .25 kPa) or less.

Ratings (See page 3 for specific limitations)

Pressure: 2.0 - 6.0 in. wg (0.5 -1.5 Pa) - pressure differential.

Velocity: 3000 to 6000 fpm (15.2 - 30.5 m/s)

Leakage: 4 cfm/ft² @ 4 in. wg (73 cmh/m² @ 1 kPa)
2 cfm/ft² @ 1 in. wg (37 cmh/m² @ 0.25 kPa)

Temperature: 180°F (82°C)

Construction	Standard	Optional
Frame Material	Aluminum	-
Frame Material Thickness	.125 in. (3.2mm) minimum wall thickness	-
Frame Type	4 in. x 1in. (102mm x 25mm) hat channel	Single Flange, Reverse Flange
Blade Material	Extruded Aluminum	-
Blade Type	Airfoil	-
Blade Action	Opposed	Parallel
Linkage	Plated steel out of airstream, concealed in jamb	304SS
Axle Bearings	Synthetic (acetal) sleeve	Bronze, 304SS
Axle Material	Plated steel	304SS
Blade Seals	EPDM	Silicone
Jamb Seals	304SS	-
Finish	Mill finish	Baked Enamel, Epoxy, Hi Pro Polyester, Industrial Epoxy, Kynar/Hylar (70% Kynar), Permatector™

W x H	Minimum Size	Maximum Size	
		Single Section	Multiple Section
Inches	6 x 6	60 x 74	Unlimited
mm	152 x 152	1524 x 1880	Unlimited

Blade Overlap

Blades overlap to provide added resistance to leakage. When pressure increases, the blade seals are forced together creating a tighter seal.

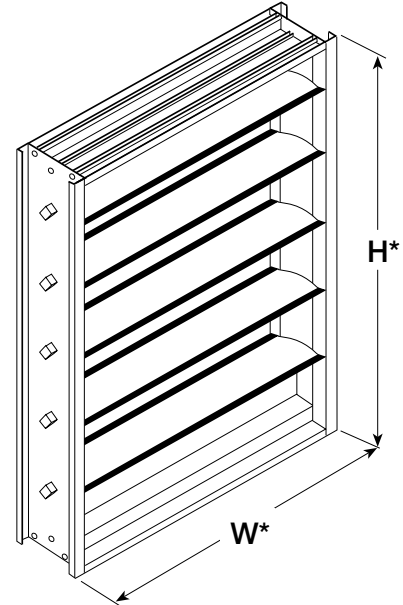
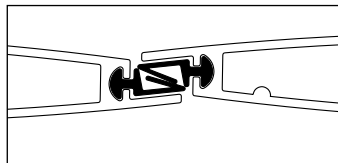

*W&H dimension furnished approximately 1/4 in. (6mm) undersize.

Flange Options

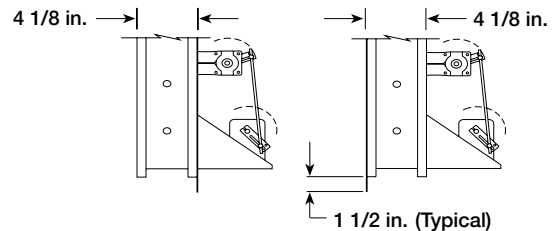

Single Flange

Single Reversed Flange

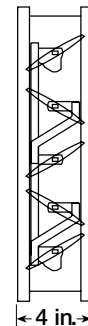
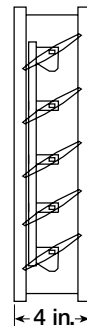

Parallel Blades Opposed Blades

FEATURES:

- Frames are constructed with reinforced corners. Low profile head and sill are used on sizes less than 17 in. high (432mm).
- Airfoil (streamlined) blade shape for reduced turbulence and lower pressure drop at velocities to 6000 fpm (1.5 kPa).

Installation installations available at www.greenheck.com

This pressure drop testing was conducted in accordance with AMCA Standard 500-D using the three configurations shown. All data has been corrected to represent standard air at a density of 0.075 lb/ft³(1.201kg/m³).

Actual pressure drop found in any HVAC system is a combination of many factors. This pressure drop information along with an analysis of other system influences should be used to estimate actual pressure losses for a damper installed in a given HVAC system.

AMCA Test Figures

Figure 5.3 Illustrates a fully ducted damper. This configuration has the lowest pressure drop of the three test configurations because entrance and exit losses are minimized by straight duct runs upstream and downstream of the damper.

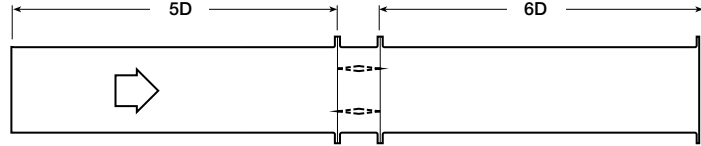
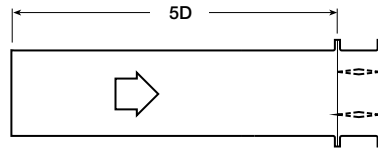
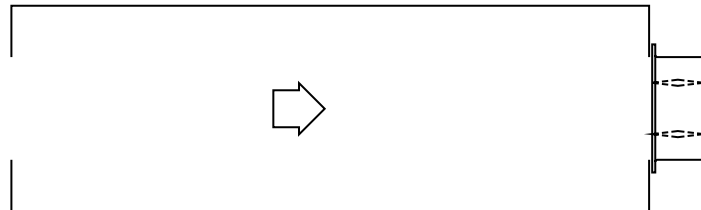

Figure 5.2 Illustrates a ducted damper exhausting air into an open area. This configuration has a lower pressure drop than Figure 5.5 because entrance losses are minimized by a straight duct run upstream of the damper.



$$D \sqrt{\frac{4(W)(H)}{3.14}}$$

Figure 5.5 Illustrates a plenum mounted damper. This configuration has the highest pressure drop because of extremely high entrance and exit losses due to the sudden changes of area in the system.



**Damper Size
12 in. x 12 in.**

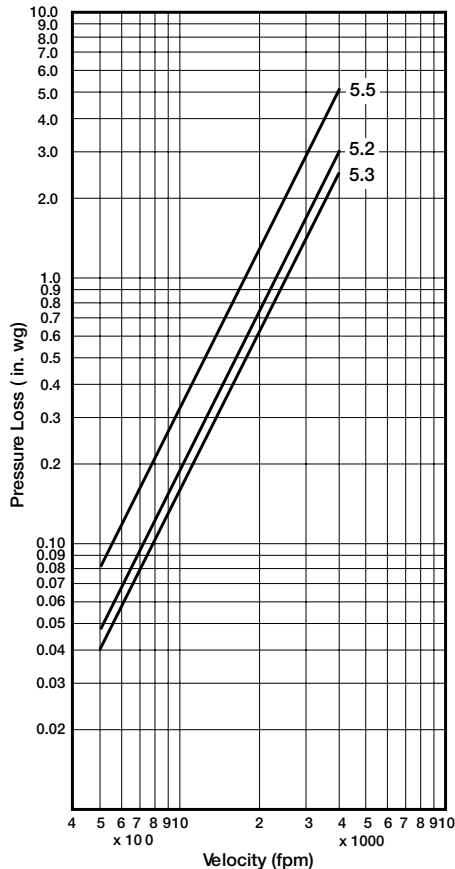

**Damper Size
24 in. x 24 in.**

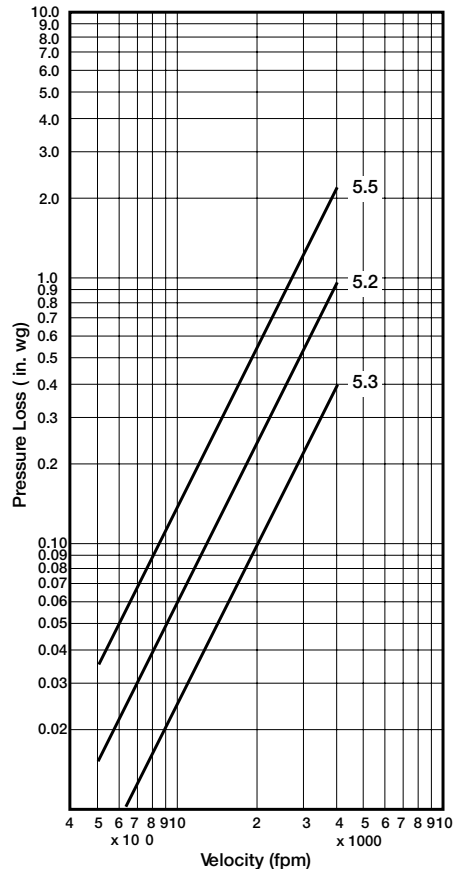

Leakage Data

Damper leakage (with blades fully closed) varies based on the type of low leakage seals applied. Model VCD-40 is available with silicone blade seals and aluminum jamb seals (standard) or optional stainless steel jamb seals. Leakage testing was conducted in accordance with AMCA Standard 500-D and is expressed as cfm/ft² of damper face area. All data has been corrected to represent standard air at a density of 0.075 lb/ft³ (1.201kg/m³).

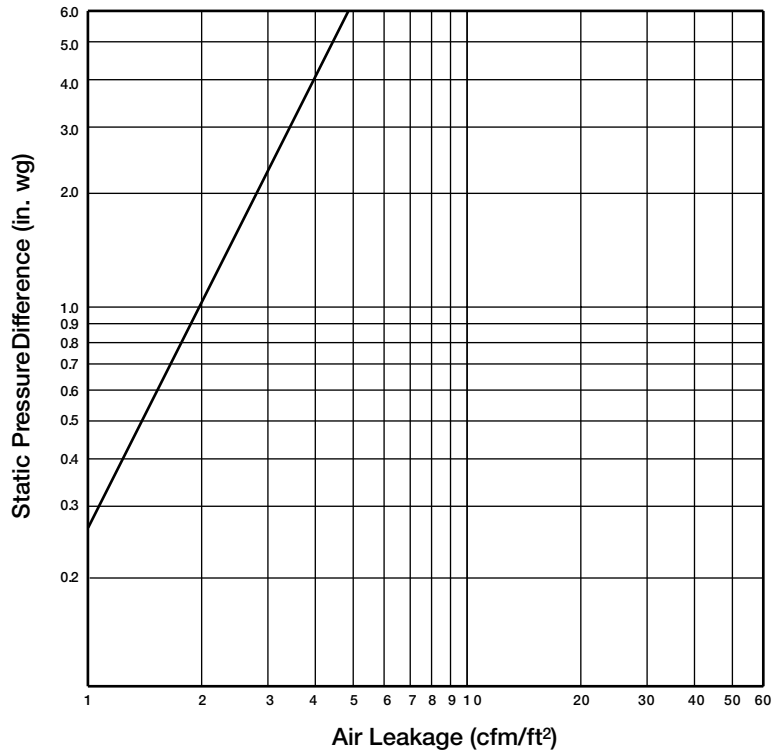

Selection Criteria

Pressure Limitations

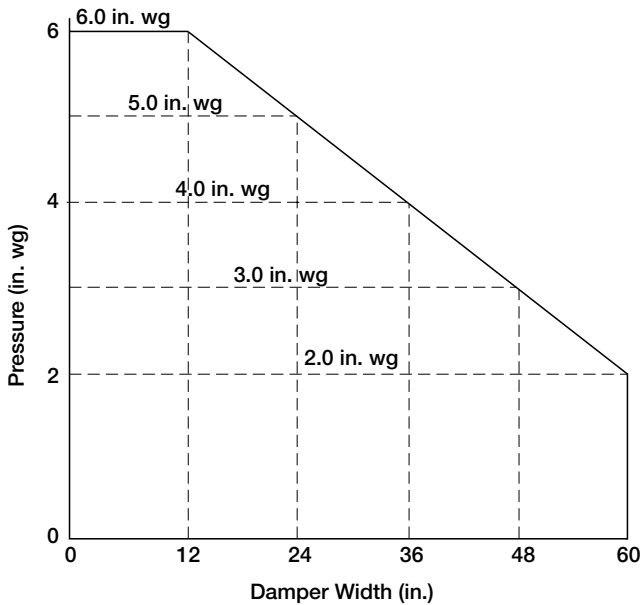

Velocity Limitations

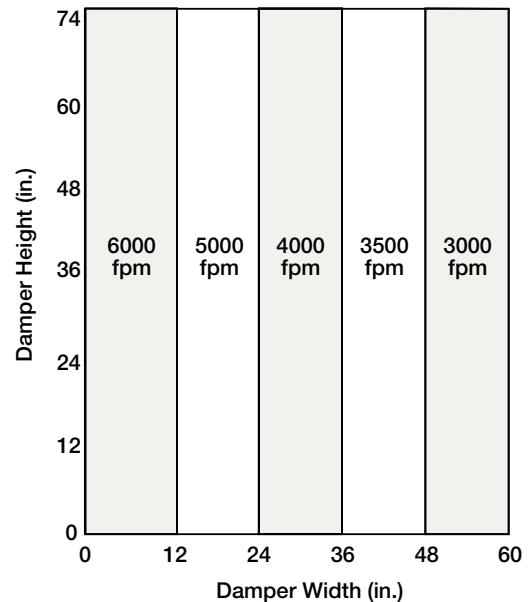

NOTE: VCD-40 will withstand higher pressures and velocities. Displayed ratings are conservative to prevent misapplication. Consult Greenheck if you have an application outside these limitations. Temperatures in excess of 180°F (82°C) require special consideration.

Multi-Section Assembly

Dampers larger than the maximum single section size, will be made up of a multiple of equal size sections. Multiple section dampers can be jackshafted together so that all sections operate together as shown below.

NOTE: Dampers larger than 60 in. x 74 in. (1524mm x 1880mm) are not intended to be structurally self supporting. Additional horizontal bracing is recommended to support the weight of the damper and vertical bracing should be installed as required to hold against system pressure.

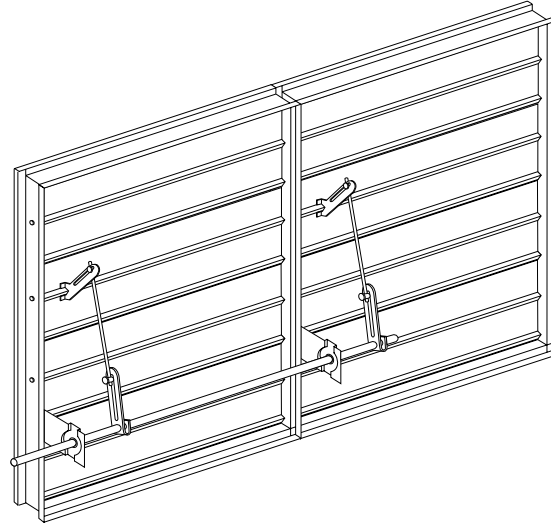

Face and Bypass Configurations

VCD-40 series control dampers can be assembled for face and bypass configurations. Face and bypass dampers are available in vertical, horizontal and right angle arrangements as shown below.

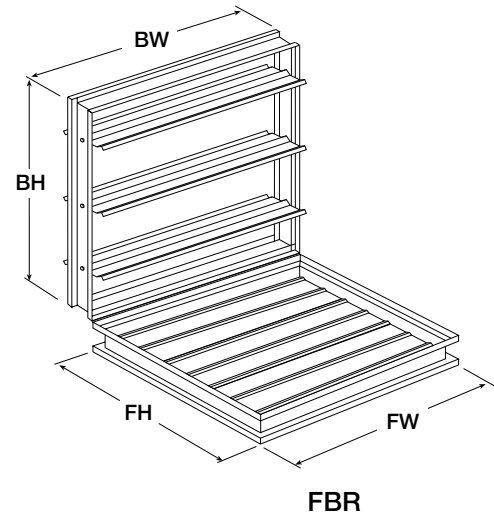
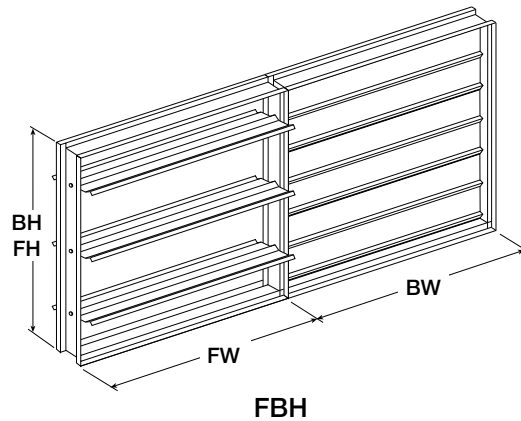
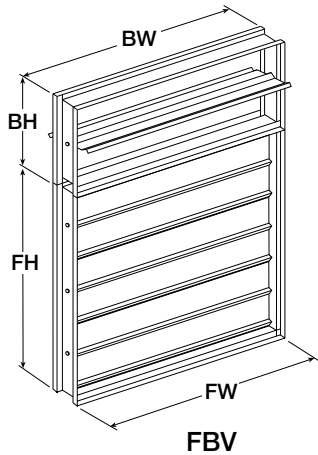

Specifications

Control dampers meeting the following specifications shall be furnished and installed where shown on plans and/or as described in schedules.

Dampers shall consist of: heavy gauge aluminum frame (0.125 in. [3.2mm] thick) with 4 in. (101mm) depth formed into a structural hat channel shape with reinforced corners; airfoil shaped, extruded aluminum blades (0.063 in. [1.6mm] thick) with metal blade to blade overlap (seal to seal only contact is not acceptable); blades shall be completely symmetrical relative to their axle pivot point, presenting identical resistance to airflow and operation in either direction through the damper (blades that are non-symmetrical relative to their axle pivot point or utilize blade stops larger than 1/2 in. [13mm] are unacceptable); 1/2 in. (13mm) dia. plated steel axles turning in synthetic (acetal) sleeve bearings; silicone blade

seals; flexible stainless steel jamb seals; and external (out of the airstream) blade-to-blade linkage. Damper manufacturer's printed application and performance data including pressure, velocity and temperature limitations shall be submitted for approval showing damper suitable for pressures to 6 in. wg (1.5 kPa), velocities to 6000 fpm (30.5m/s) and temperatures to 250°F (121°C).

Damper manufacturer's printed performance data showing standard air leakage less than 4 cfm/ft² @ 4 in. wg (73 cmh/m² @ 1 kPa) in either direction through the damper shall be submitted for approval. Damper testing and ratings shall be developed in accordance with the latest edition of AMCA Standard 500-D.

Basis of design is Greenheck model VCD-40.

