



# Model SMD-401 Smoke Dampers

**Extruded Airfoil Blades  
UL 555S Leakage Class I**

## APPLICATION

Model SMD-401 is a class I leakage rated smoke damper. High strength, streamlined extruded airfoil blades insure lowest resistance to airflow in HVAC systems with velocities to 3000 fpm (15.2 m/s) and 6 in. wg (1.5 kPa). Model SMD-401 may be installed vertically (with blades running horizontal) or horizontally and is rated for airflow and leakage in either direction.

## RATINGS

- Leakage:** UL 555S leakage class I. Leakage rated in both directions
- Velocity:** Operational rated to 3000 fpm (15.2 m/s) for sizes up to 48 in. W x 108 in. H or 144 in. H x 36 in. H (1219mm x 2743mm) or (3658mm x 914mm) or 2000 fpm (10.2 m/s) for sizes greater than that. Rating is for airflow in either direction through damper.
- Temperature:** 250°F (121°C) with all actuators.
- Maximum Pressure:** 6 in. (1.5 kPa)

Model SMD-401 meets the requirements for smoke dampers established by:

- National Fire Protection Association**  
NFPA Standards 92A, 92B, 101 & 105
- IBC International Building Codes**
- New York City (MEA listing #260-91-M)**
- California State Fire Marshall**  
Listing#: 3230-0981:104 (smoke)

**“UL CLASSIFIED (see complete marking on product)”**

**“UL CLASSIFIED to Canadian safety standards (see complete marking on product)”**  
Standard 555S (Listing #R13317)

Construction	Standard	Optional
Frame Material	Galvanized steel	-
Frame Material Thickness	16 ga. (1.5mm)	-
Frame Type	5 in. x 1 in. (127mm x 25mm) hat channel	Double Flange
Blade Material	Aluminum	-
Blade Material Thickness	Heavy gauge aluminum	-
Blade Type	Airfoil	-
Linkage	Plated steel out of airstream, concealed in jamb	304SS
Axle Bearings	Bronze	304SS
Axle Material	Plated steel	304SS
Blade Seals	Silicone	-
Jamb Seals	304SS	-

FM Approvals  
SPECIFICATION TESTED PRODUCT  
(OPTION)



## Size Limitations

W x H	Minimum Size	Maximum Size	
		Single Section	Multiple Section
<b>2000 fpm (10.2 m/s); 4 in. wg (1 kPa) pressure</b>			
Inches	8 x 8	48 x 60	192 x 72 or 48 x 288 or 384 x 36
mm	203 x 203	1219 x 1524	4877 x 1829 or 1219 x 7315 or 9754 x 914
<b>3000 fpm (15.2 m/s); 4 in. wg (1 kPa) pressure</b>			
Inches	8 x 8	48 x 36	144 x 36 or 48 x 108
mm	203 x 203	1219 x 914	3658 x 914 or 1219 x 2743
<b>3000 fpm (15.2 m/s); 6 in. wg (1.5 kPa) pressure</b>			
Inches	8 x 8	48 x 36	-
mm	203 x 203	1219 x 914	-

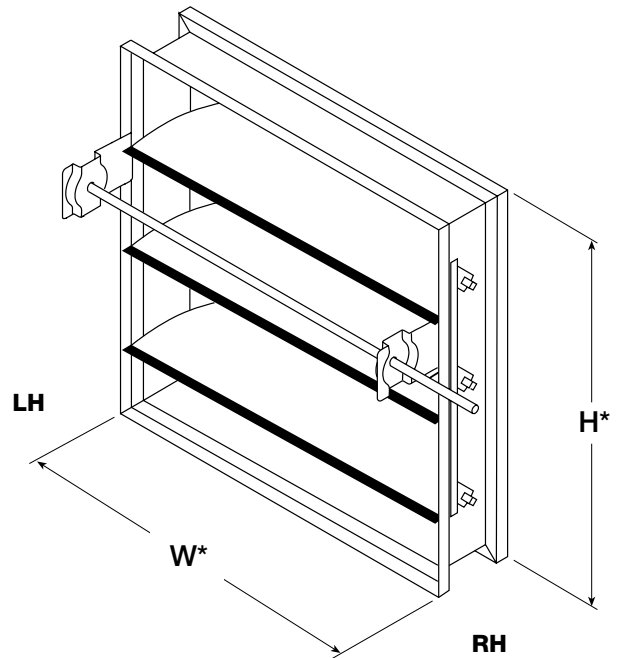

\*W&H dimensions furnished approximately 1/4 in. (6mm) undersize. (Add sleeve thickness for overall sleeved damper dimension)  
Right hand drive is shown. Left hand drive is available upon request.

## Features:

- Frames are constructed with reinforced corners. Low profile head and sill are used on sizes less than 17 in. high (432mm).
- Blades are extruded aluminum airfoil, symmetrically shaped.
- Actuators: 120V, 24V, 230V, Pneumatic

Installation instructions available at [www.greenheck.com](http://www.greenheck.com)

## Options for SMD-401:

- Factory mounted accessories
  - Retaining angles
  - Quick connect breakaway connections
  - S & drive connections
  - Access doors
- Greenheck test switches (GTS-3 & GTS-4)
- Momentary test switch
- POC retaining angles
- OCI (Open closed indication switches)
- Sealed transitions and sleeves
- Security bars
- Smoke detectors
- Transitions: R, C, O

## Pressure Drop Data

This pressure drop testing was conducted in accordance with AMCA Standard 500-D using the three configurations shown. All data has been corrected to represent standard air at a density of .075 lb/ft<sup>3</sup> (1.201 kg/m<sup>3</sup>).

Actual pressure drop found in any HVAC system is a combination of many factors. This pressure drop information along with an analysis of other system influences should be used to estimate actual pressure losses for a damper installed in a given HVAC system.

### AMCA Test Figures

**Figure 5.3** Illustrates a fully ducted damper. This configuration has the lowest pressure drop of the three test configurations because entrance and exit losses are minimized by straight duct runs upstream and downstream of the damper.

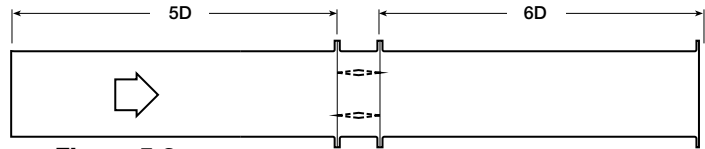

**Figure 5.3**

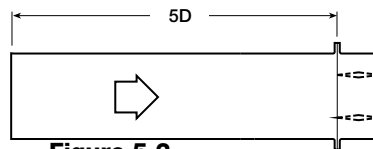

**Figure 5.2**

$$D = \sqrt{\frac{4(W)(H)}{3.14}}$$

**Figure 5.2** Illustrates a ducted damper exhausting air into an open area. This configuration has a lower pressure drop than Figure 5.5 because entrance losses are minimized by a straight duct run upstream of the damper.

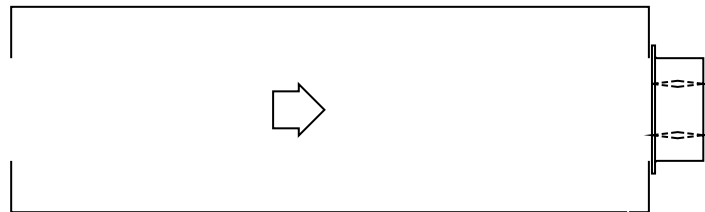

**Figure 5.5**

**Figure 5.5** Illustrates a plenum mounted damper. This configuration has the highest pressure drop because of extremely high entrance and exit losses due to the sudden changes of area in the system.

**Damper Size  
12 in. x 12 in.**

**Damper Size  
24 in. x 24 in.**

**Damper Size  
36 in. x 36 in.**

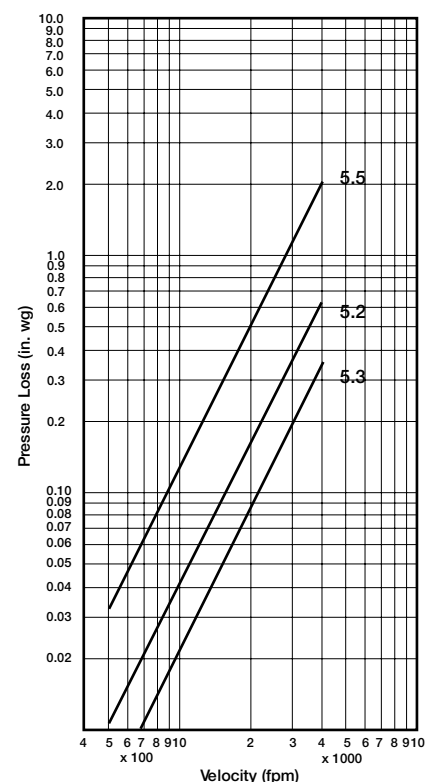
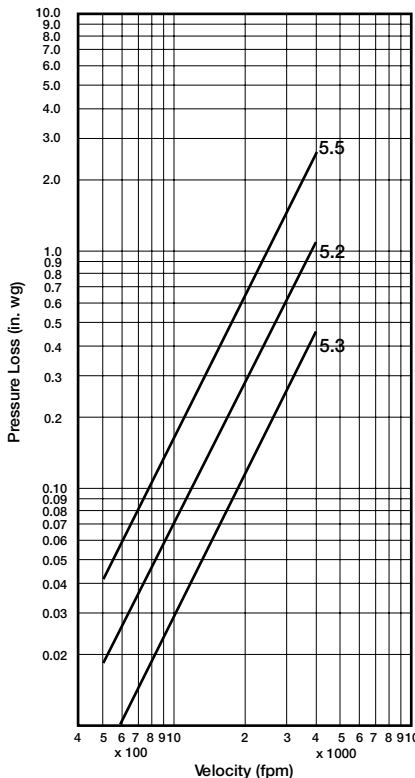
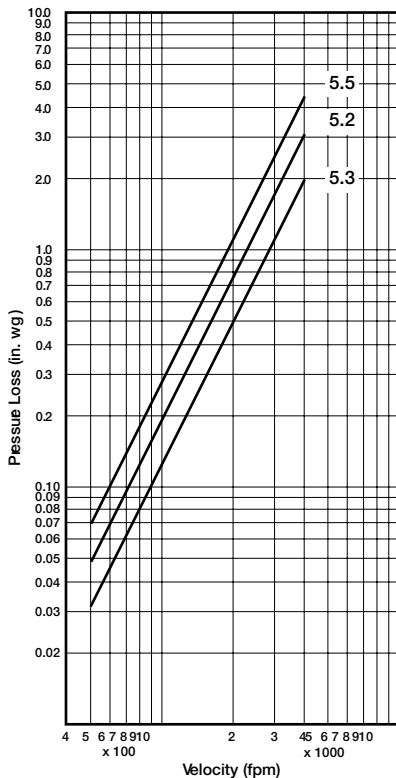

# Application Data

## Damper Sideplate and Sleeve Dimensional Data

The drawings below illustrate the factory standard sideplate and sleeve mountings for the SMD-401. The standard "A" dimensions listed in the table provide adequate space for the mounting of actuators and controls.

If space constraints are a problem the "A" dimension can be varied between 5 3/8 in. (136mm) and 12 in. (305mm).

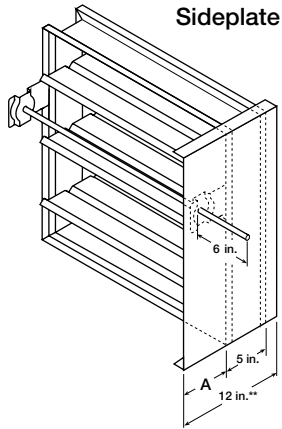

in. (mm)	"A" Dimension		
	Sleeve		Sideplate
	Standard	Maximum	
All Dampers*	7 3/16 (183)	12 (305)	6 3/16 (157)
When height is 11 in. (279) or less with OCI	11 3/16 (284)	12 (305)	10 3/16 (259)

\*With the exception of dampers 11 in. (279mm) high or less (12 in. (305mm) high or less if width is greater than 64 in. (1625mm)) with OCI option.

\*\* On dampers 11 in. (279mm) high or less (12 in. (305mm) high or less if width is greater than 64 in. (1625mm)) with OCI option, sideplate is 16 in. (406mm)

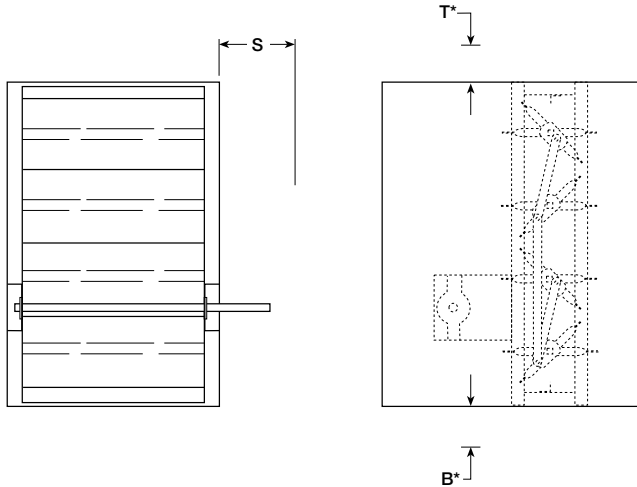
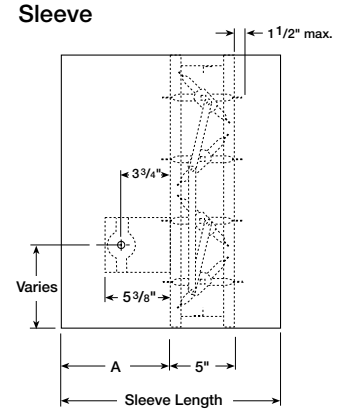

## Space Envelopes Required for Actuators and Accessories

Externally mounted actuators always require space outside of the damper sideplate or sleeve. The "S" dimension illustrates the clearance required for various available actuators.

On dampers less than 18 in. (457mm) high, actuators may also require clearances above and/or below the sideplate or sleeve. "B" and "T" dimensions are **worst** case clearance requirements for some dampers less than 18 in. (457mm) high. All damper sizes under 18 in. (457mm) high do not require these worst case clearances. If space availability above or below the damper sleeve is limited, each damper size should be individually evaluated.

Actuator Type/Model	B*	T*	S	
	With RRL, RRL/OCI, or TOR	With RRL, RRL/OCI, or TOR	PiggyBack	
			No	Yes
<b>120 Volt AC</b>				
ML-4XXX Series Honeywell	5 1/4 in. (133mm)	3/4 in. (19mm)	6 in. (152mm)	NA
MS-4XXX Series Honeywell	6 in. (152mm)	3/8 in. (10mm)	6 in. (152mm)	NA
MS-4120 Series Honeywell	6 in. (152mm)	3/8 in. (10mm)	6 in. (152mm)	9 in. (229mm)
<b>24 Volt AC</b>				
ML-8XXX Series Honeywell	5 1/4 in. (133mm)	3/4 in. (19mm)	6 in. (152mm)	NA
MS-8XXX Series Honeywell	6 in. (152mm)	6 in. (152mm)	6 in. (152mm)	NA
MS-8120 Series Honeywell	6 in. (152mm)	6 in. (152mm)	6 in. (152mm)	9 in. (229mm)
<b>Pneumatic (25 psi min.)</b>				
331-4551 Powers	1 in. (25mm)	6 1/4 in. (159mm)	6 1/2 in. (165mm)	NA
331-2976 Powers	2 3/8 in. (60mm)	12 1/8 in. (308mm)	9 1/4 in. (235mm)	NA
MK2-7121 Invensys	3 3/4 in. (95mm)	16 1/2 in. (419mm)	10 in. (254mm)	NA

\* For dampers 18 in. (457mm) or more in height these dimensions are 0 in. .

# Damper Sizing Information

Dampers larger than maximum single section size are supplied as a factory assembly of two or more sections of equal size.

The following figure shows the size damper section that has been qualified for operation with a single actuator. Larger sizes can be accommodated using multiples of these assemblies.

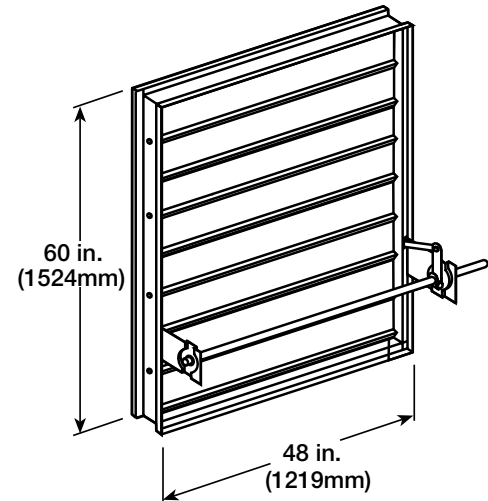

## Transitioned Damper Dimensions

When a fire/smoke damper is being used in conjunction with round or oval ductwork, the SMD-401 can be supplied in a factory sleeve with round or oval transitions on both ends of the sleeve. Dampers should be ordered to the duct dimensions. Drawings below show overall damper size.

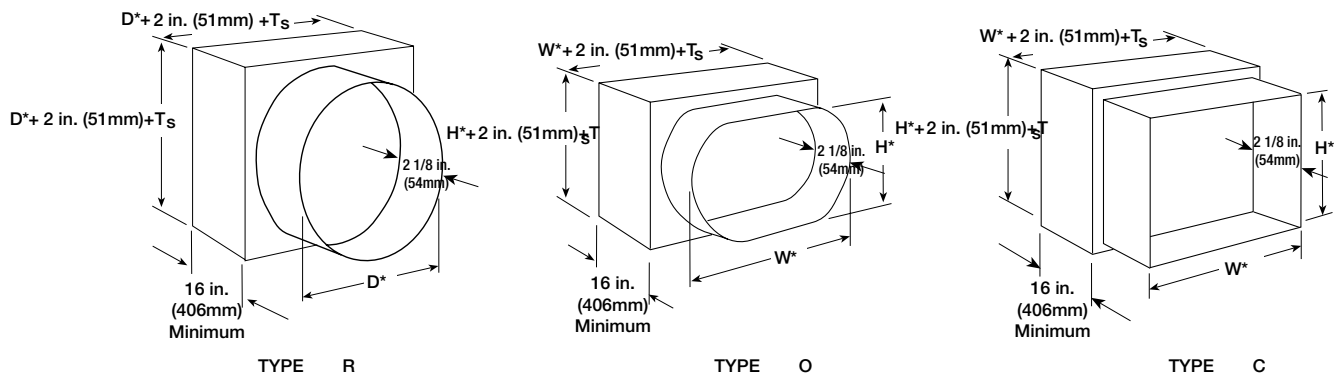

\* These dimensions are furnished approximately 1/4 in. (6mm) undersize, except round and oval dimensions which are approximately 1/8 in. (3mm) undersize.  
 $T_s = (2)(\text{Sleeve Thickness})$

## Specifications

Smoke Dampers meeting the following specifications shall be furnished and installed where shown on plans and/or as described in schedules. Dampers shall meet the requirements of NFPA 92A, 92B, 101, & 105 and further shall be tested, rated and labeled in accordance with the latest edition of UL Standard 555S. Smoke dampers shall be of low leakage design qualified to UL 555S Leakage Class I.

Each damper/actuator combination shall have a UL555S elevated temperature rating of 250°F (121°C) minimum and shall be rated to operate at maximum design airflow at its installed location. Each damper shall be supplied with an appropriate actuator installed by the damper manufacturer at the time of damper fabrication. Damper actuator shall be (specifier select one of the following) electric type for 120, 24, or 240 Volt operation or pneumatic type for 25 psi minimum (30 psi maximum operation).

Damper blades shall be hollow extruded aluminum airfoil type with structural reinforcing tube running full length of each blade. Damper frame shall be galvanized steel formed into a structural hat channel shape with reinforced corners. Bearings shall be sintered bronze sleeve type rotating in extruded holes in the damper frame. Blade edge seals shall be silicone rubber designed to inflate and provide a tighter seal against leakage as pressure on either side of the damper increases. Jamb seals shall be stainless steel compression type.

Damper must be rated for mounting vertically (with blades running horizontal) or horizontally and be UL 555S rated for leakage and airflow in either direction through the damper.

The basis of design is Greenheck Model SMD-401.

