

APPLICATION

Model SMD-302M is a leakage rated modulating smoke damper with class II leakage. The SMD-302M serves the function of both a control damper and smoke damper. High strength airfoil blades insure lowest resistance to airflow in HVAC systems with velocities to 2000 fpm (10.2m/s) and 4 in. wg (1 kPa) Model SMD-302M may be installed vertically (with blades running horizontal) or horizontally and is rated for airflow and leakage in either direction.

UL 555S Leakage Rating

Leakage Class: II

Operational Rating

Maximum Velocity: 2000 fpm (10.2m/s)

Maximum Pressure: 4 in. wg (1 kPa)

Maximum Temperature: 250°F (121°C)

Construction	Standard	Optional
Frame Material	Galvanized Steel	-
Frame Material Thickness	16 ga. (1.5mm)	-
Frame Type	5 in. x 1 in. (127mm x 25mm) hat channel	-
Blade Material	Galvanized Steel	-
Blade Material Thickness	14 ga. (2mm) Equivalent	-
Blade Type	Double Skin Airfoil	-
Linkage	Plated Steel Out of Airstream, Concealed in Jamb	-
Axle Bearings	Bronze	304SS
Axle Material	Plated Steel	-
Blade Seals	Silicone	-
Jamb Seals	304SS	-

Size Limitations

W x H	Minimum Size	Maximum Size	
		Single Section	Multiple Section
Inches	8 x 6	32 x 50	128 x 100
mm	203 x 152	813 x 1270	3251 x 2540

OPTIONS:

- Factory mounted accessories
 - Retaining angles
 - Quick connect breakaway connections
 - S & drive connections
 - Access doors
- Greenheck test switches (GTS-3 & GTS-4)
- Momentary test switch
- POC retaining angles
- OCI (Open closed indication switches)
- Sealed transitions and sleeves
- Security bars
- Smoke detectors
- Transitions: R, C, O

Model SMD-302M meets the requirements for smoke dampers established by:

National Fire Protection Association

NFPA Standards 92A, 92B, 101 & 105

IBC International Building Codes

New York City (MEA listing #260-91-M)

CSFM California State Fire Marshal

Leakage (Smoke) Damper Listing (#3230-0981:104)

"UL CLASSIFIED (see complete marking on product)"

"UL CLASSIFIED to Canadian safety standards (see complete marking on product)"

Standard 555S (Listing #R13317)

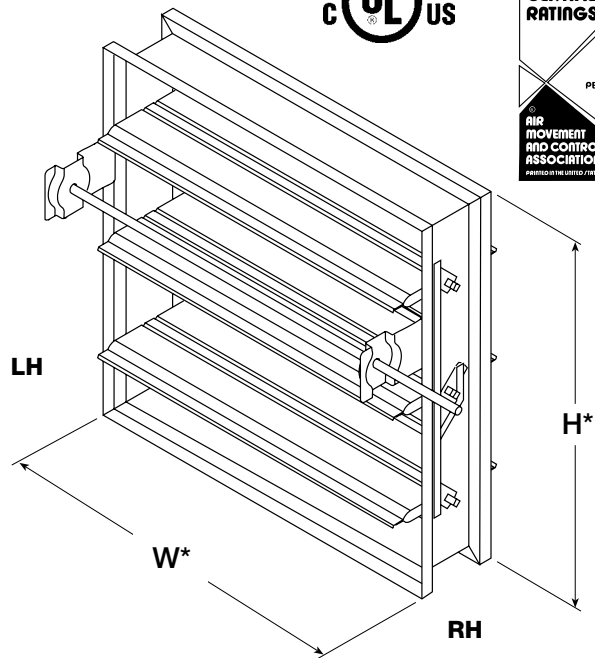

*W&H dimensions furnished approximately 1/4 in. (6mm) undersize. Right hand drive is shown. Left hand drive is available upon request. Damper also may be rotated 180° in the field for opposite side drive. (Add sleeve thickness for overall sleeved damper dimension)

Features:

- Frames are constructed with reinforced corners. Low profile head and sill are used on sizes less than 17 in. high (432mm).
- Blades are double skin airfoil shape of galvanized steel with full length structural reinforcement
- Actuators: 24V

This pressure drop testing was conducted in accordance with AMCA Standard 500-D using the three configurations shown. All data has been corrected to represent standard air at a density of .075 lb/ft³ (1.201 kg/m³).

Actual pressure drop found in any HVAC system is a combination of many factors. This pressure drop information along with an analysis of other system influences should be used to estimate actual pressure losses for a damper installed in a given HVAC system.

AMCA Test Figures

Figure 5.3 Illustrates a fully ducted damper. This configuration has the lowest pressure drop of the three test configurations because entrance and exit losses are minimized by straight duct runs upstream and downstream of the damper.

Figure 5.2 Illustrates a ducted damper exhausting air into an open area. This configuration has a lower pressure drop than Figure 5.5 because entrance losses are minimized by a straight duct run upstream of the damper.

Figure 5.5 Illustrates a plenum mounted damper. This configuration has the highest pressure drop because of extremely high entrance and exit losses due to the sudden changes of area in the system.

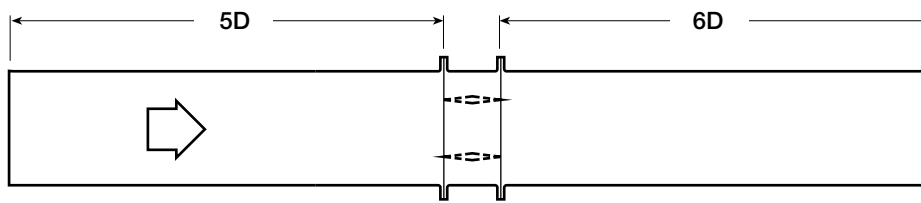

Figure 5.3

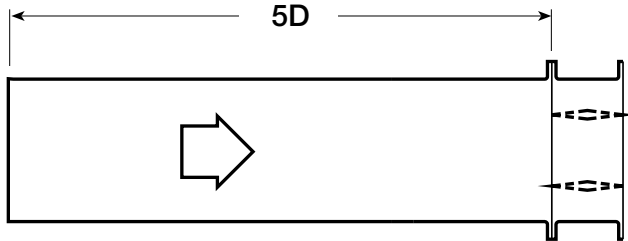

Figure 5.2

$$D = \sqrt{\frac{4(W)(H)}{3.14}}$$

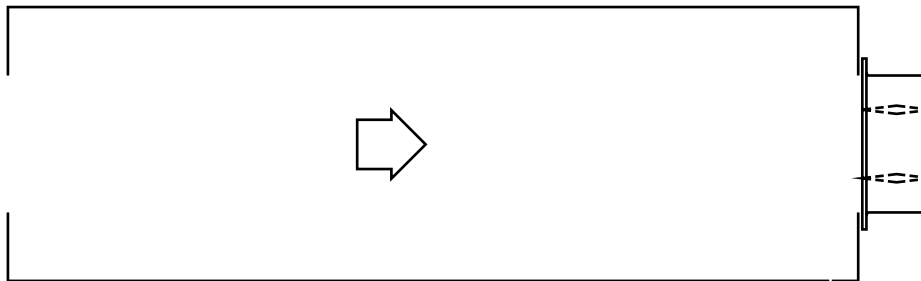
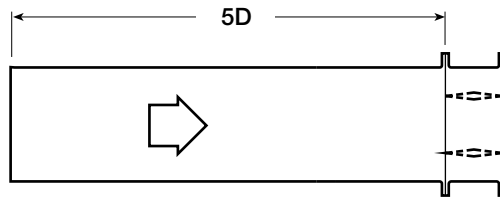

Figure 5.5

Pressure Drop

SMD-302M

AMCA Figure 5.2



12 in. x 12 in. (305mm x 305mm)

Velocity (fpm)	Pressure Drop (in. wg)
500	0.03
1000	0.12
1500	0.26
2000	0.46
2500	0.72
3000	1.04
3500	1.41
4000	1.84

24 in. x 24 in. (610mm x 610mm)

Velocity (fpm)	Pressure Drop (in. wg)
500	0.01
1000	0.06
1500	0.12
2000	0.22
2500	0.34
3000	0.49
3500	0.67
4000	0.87

36 in. x 36 in. (914mm x 914mm)

Velocity (fpm)	Pressure Drop (in. wg)
500	0.01
1000	0.06
1500	0.12
2000	0.22
2500	0.34
3000	0.49
3500	0.67
4000	0.88

12in. X 48 in. (305mm x 1219mm)

Velocity (fpm)	Pressure Drop (in. wg)
500	0.01
1000	0.05
1500	0.12
2000	0.21
2500	0.33
3000	0.48
3500	0.65
4000	0.85

48 in. x 12 in. (1219mm x 305mm)

Velocity (fpm)	Pressure Drop (in. wg)
500	0.02
1000	0.08
1500	0.18
2000	0.33
2500	0.51
3000	0.74
3500	1.00
4000	1.31

AMCA Figure 5.3

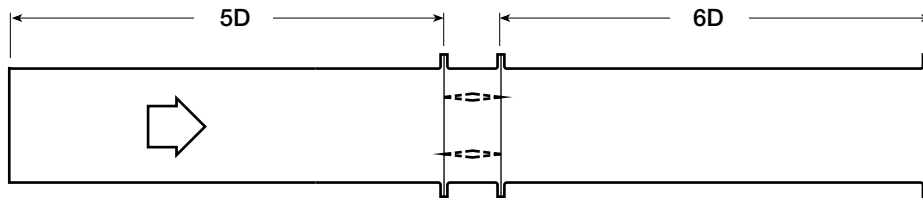

12 in. x 12 in. (305mm x 305mm)

Velocity (fpm)	Pressure Drop (in. wg)
500	0.01
1000	0.06
1500	0.13
2000	0.23
2500	0.37
3000	0.53
3500	0.73
4000	0.95

24 in. x 24 in. (610mm x 610mm)

Velocity (fpm)	Pressure Drop (in. wg)
500	0.01
1000	0.02
1500	0.06
2000	0.10
2500	0.16
3000	0.23
3500	0.32
4000	0.42

36 in. x 36 in. (914mm x 914mm)

Velocity (fpm)	Pressure Drop (in. wg)
500	0.01
1000	0.02
1500	0.05
2000	0.09
2500	0.14
3000	0.21
3500	0.29
4000	0.38

12in. X 48 in. (305mm x 1219mm)

Velocity (fpm)	Pressure Drop (in. wg)
500	0.01
1000	0.02
1500	0.06
2000	0.10
2500	0.16
3000	0.24
3500	0.33
4000	0.43

48 in. x 12 in. (1219mm x 305mm)

Velocity (fpm)	Pressure Drop (in. wg)
500	0.01
1000	0.04
1500	0.10
2000	0.18
2500	0.29
3000	0.42
3500	0.57
4000	0.74

AMCA Figure 5.5

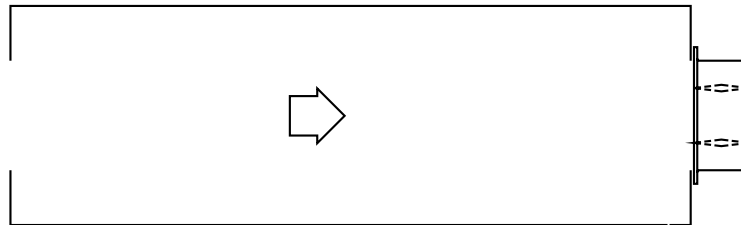

12 in. x 12 in. (305mm x 305mm)

Velocity (fpm)	Pressure Drop (in. wg)
500	0.04
1000	0.18
1500	0.42
2000	0.75
2500	1.17
3000	1.68
3500	2.29
4000	2.09

24 in. x 24 in. (610mm x 610mm)

Velocity (fpm)	Pressure Drop (in. wg)
500	0.03
1000	0.13
1500	0.29
2000	0.52
2500	0.81
3000	1.17
3500	1.60
4000	2.14

36 in. x 36 in. (914mm x 914mm)

Velocity (fpm)	Pressure Drop (in. wg)
500	0.03
1000	0.12
1500	0.27
2000	0.48
2500	0.75
3000	1.08
3500	1.48
4000	1.93

12in. X 48 in. (305mm x 1219mm)

Velocity (fpm)	Pressure Drop (in. wg)
500	0.03
1000	0.12
1500	0.27
2000	0.49
2500	0.77
3000	1.11
3500	1.51
4000	1.97

48 in. x 12 in. (1219mm x 305mm)

Velocity (fpm)	Pressure Drop (in. wg)
500	0.03
1000	0.14
1500	0.32
2000	0.57
2500	0.89
3000	1.28
3500	1.75
4000	2.29



Greenheck Fan Corporation certifies that the model SMD-302M shown herein is licensed to bear the AMCA Seal. The ratings shown are based on tests and procedures performed in accordance with AMCA Publication 511 and comply with the requirements of the AMCA Certified Ratings Programs. The AMCA Certified Ratings Seal applies to air performance ratings only.

Application Data

Space Envelopes Required for Actuators and Accessories

Externally mounted actuators always require space outside of the damper sideplate or sleeve. The "S" dimension illustrates the clearance required for various available actuators.

On dampers less than 18 in. (457mm) high, actuators may also require clearances above and/or below the sideplate or sleeve. "B" and "T" dimensions are **worst** case clearance requirements for some dampers less than 18 in. (457mm) high. All damper sizes under 18 in. (457mm) high do not require these worst case clearances. If space availability above or below the damper sleeve is limited, each damper size should be individually evaluated.

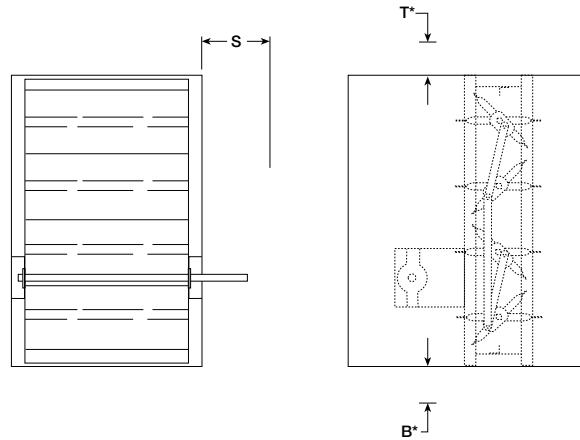

Actuator Type/Model	B*	T*	S	
	With OCI, RRL, or TOR	With OCI, RRL, or TOR	Piggy back	
			No	Yes
24 Volt AC				
MS7520A2015/B MS7520A2213/B	12 3/4 in. (324mm)	0	6 in. (152mm)	9 in. (229mm)

* For dampers 18 in.(457mm) or more in height these dimensions are 0 in.

Damper Sideplate and Sleeve Dimensional Data

The drawings below illustrate the factory standard sideplate and sleeve mountings for the SMD-302M. The standard "A" dimensions listed in the table provide adequate space for the mounting of actuators and controls.

If space constraints are a problem the "A" dimension can be varied between 5³/₈ in. (136mm) and 12 in. (305mm).

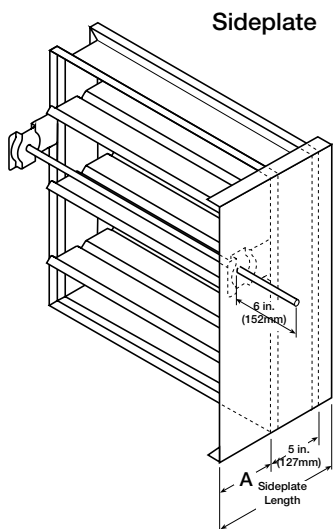

in. (mm)	"A" Dimension		
	Sleeve		Sideplate
	Standard	Maximum	
All Dampers*	7 3/16 (183)	12 (305)	6 3/16 (157)
When height is 11 in. (279) or less with OCI	11 3/16 (284)	12 (305)	10 3/16 (259)

*With the exception of dampers 11 in. (279mm) high or less (12 in. (305mm) high or less if width is greater than 64 in. (1625mm)) with OCI option.

** On dampers 11 in. (279mm) high or less (12 in. (305mm) high or less if width is greater than 64 in. (1625mm)) with OCI option, sideplate is 16 in. (406mm)

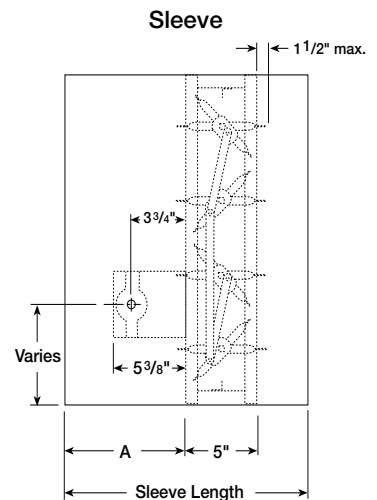

Damper Sizing Information

Dampers larger than maximum single section size are supplied as a factory assembly of two or more sections of equal size.

The following figures show damper sections and assemblies that have been qualified for operation with a single actuator. Larger sizes can be accommodated using multiples of these assemblies.

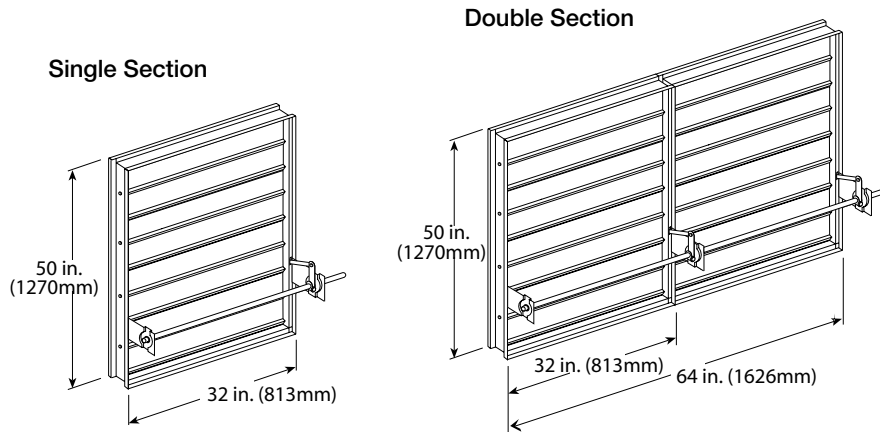

Transitioned Damper Dimensions

When a fire/smoke damper is being used in conjunction with round or oval ductwork, the SMD-302M can be supplied in a factory sleeve with round or oval transitions on both ends of the sleeve. Dampers should be ordered to the duct dimensions. Drawings below show overall damper size.

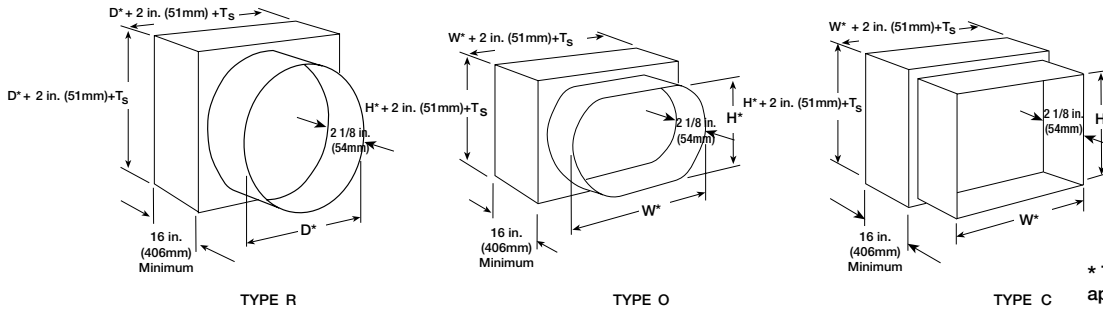

* These dimensions are furnished approximately 1/4 in. (6mm) undersize, except round and oval dimensions which are approximately 1/8 in. (3mm) undersize.

T_S = (2)(Sleeve Thickness)

Specifications

Smoke Dampers meeting the following specifications shall be furnished and installed where shown on plans and/or as described in schedules. Dampers shall meet the requirements of NFPA 92A, 92B, 101, and 105 and further shall be tested, rated and labeled in accordance with the latest edition of UL Standard 555S. Smoke dampers shall be of low leakage design qualified to UL 555S Leakage Class II.

Each damper/actuator combination shall have a UL555S elevated temperature rating of 250°F (121° C) minimum and shall be rated to operate at maximum design air flow at its installed location. Each damper shall be supplied with an appropriate actuator installed by the damper manufacturer at the time of damper fabrication. Damper actuator shall be (specifier select one of the following) electric type for 24 Volt operation.

Damper blades shall be of the double skin airfoil type and

shall have an equivalent metal thickness of 14 ga. (2mm) Damper frame shall be galvanized steel formed into a structural hat channel shape with reinforced corners. Bearings shall be sintered bronze sleeve type rotating in extruded holes in the damper frame. Blade edge seals shall be silicone rubber designed to inflate and provide a tighter seal against leakage as pressure on either side of the damper increases. Jamb seals shall be stainless steel compression type with silicone rubber backing. Blades shall be completely symmetrical relative to their axle pivot point, presenting identical resistance to airflow in either direction or pressure on either side of the damper.

Damper must be rated for mounting vertically (with blades running horizontal) or horizontally and be UL 555S rated for leakage and airflow in either direction through the damper.

The basis of design is Greenheck Model SMD-302M.



P.O. Box 410 • Schofield, WI 54476-0410 • 715.359.6171 • greenheck.com

Copyright ©2011 Greenheck Fan Corporation
SMD-302M Rev. 8 December 2011