

**Application**

Model SMD-301V is a vertical blade low leakage rated smoke damper. High strength airfoil blades insure lowest resistance to airflow in HVAC systems with velocities to 4000 fpm (20.3m/s) and 4 in. wg (1.0 kPa).

**UL555S Leakage Rating**

**Leakage Class:** I

**Operational Rating**

**Maximum Velocity:** 2000 fpm (20.3 m/s) up to 100 in. x 32 in. H (2540mm x 813mm) or 4000 fpm (20.3 m/s) up to 50 in. x 32 in. (1270mm x 813mm)

**Maximum Pressure:** 4 in. wg (1 kPa)

**Maximum Temperature:** 350°F (177°C)

Construction	Standard	Optional
Frame Material	Galvanized Steel	-
Frame Material Thickness	16 ga. (1.5mm)	-
Frame Type	5 in. x 1in. (127mm x 25mm) hat channel	-
Blade Material	Galvanized Steel	-
Blade Material Thickness	14 ga. (2mm) Equivalent	-
Blade Type	Double Skin Airfoil	-
Linkage	Plated Steel Out of Airstream, Concealed in Jamb	-
Axle Bearings	304SS	-
Axle Material	Plated Steel	-
Blade Seals	Silicone	-
Jamb Seals	304SS	-

Model SMD-301V meets the requirements for smoke dampers established by:

**National Fire Protection Association**

NFPA Standards 92A, 92B, 101 & 105

**IBC International Building Codes**

New York City (MEA listing #260-91-M)

**CSFM California State Fire Marshal**

Leakage (Smoke) Damper Listing (#3230-0981:104)

**"UL CLASSIFIED (see complete marking on product)"**

**"UL CLASSIFIED to Canadian safety standards (see complete marking on product)"**

Standard 555S (Listing #R13317)

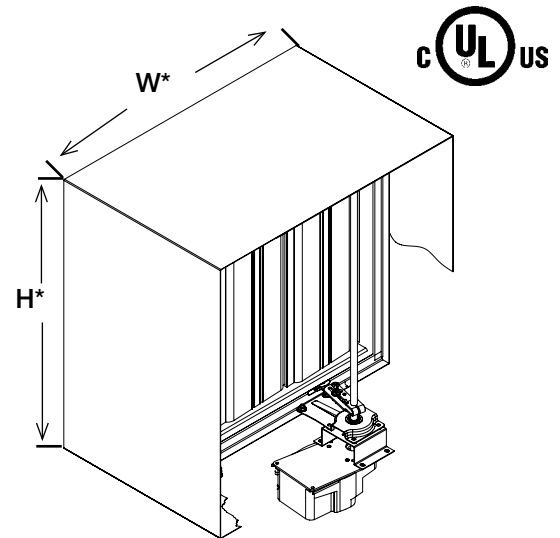

\*W&H dimensions furnished approximately 1/4 in. (6mm) undersize. (add sleeve thickness for overall sleeved damper dimension).

**Size Limitations**

W x H	Minimum Size	Maximum Size	
		Single Section	Multiple Section
<b>2000 fpm (10.2 m/s)</b>			
Inches	6 x 8	50 x 32	100 x 32
mm	152 x 203	1270 x 813	2540 x 813
<b>4000 fpm (20.3 m/s)</b>			
Inches	6 x 8	50 x 32	-
mm	152 x 203	1270 x 813	-

**Features:**

- Frames are constructed with reinforced corners. Low profile head and sill are used on sizes less than 17 in. high (432mm).
- Blades are double skin airfoil shape of galvanized steel with full length structural reinforcement
- Actuators: 24V, 120V, 230V, Pneumatic

## Options for SMD-301V:

- Factory mounted accessories
  - Retaining angles
  - Quick connect breakaway connections
  - S & drive connections
  - Access doors
- Greenheck test switches (GTS-3 & GTS-4)
- Momentary test switch
- POC retaining angles
- OCI (Open closed indication switches)
- Sealed transitions and sleeves
- Security bars
- Smoke detectors
- Transitions: R, C, O

## Pressure Drop Data

This pressure drop testing was conducted in accordance with AMCA Standard 500-D using the three configurations shown. All data has been corrected to represent standard air at a density of .075 lb/ft<sup>3</sup> (1.2 kg/m<sup>3</sup>).

Actual pressure drop found in any HVAC system is a combination of many factors. This pressure drop information along with an analysis of other system influences should be used to estimate actual pressure losses for a damper installed in a given HVAC system.

### AMCA Test Figures

**Figure 5.3** Illustrates a fully ducted damper. This configuration has the lowest pressure drop of the three test configurations because entrance and exit losses are minimized by straight duct runs upstream and downstream of the damper.

**Figure 5.2** Illustrates a ducted damper exhausting air into an open area. This configuration has a lower pressure drop than Figure 5.5 because entrance losses are minimized by a straight duct run upstream of the damper.

**Figure 5.5** Illustrates a plenum mounted damper. This configuration has the highest pressure drop because of extremely high entrance and exit losses due to the sudden changes of area in the system.

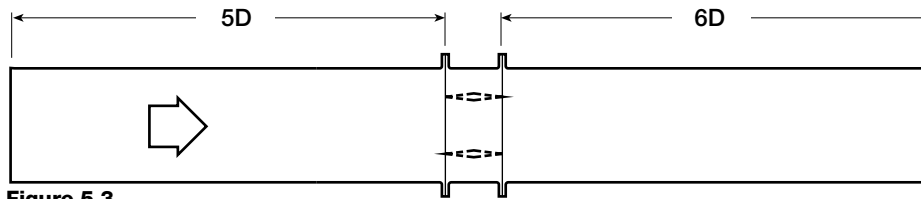

Figure 5.3

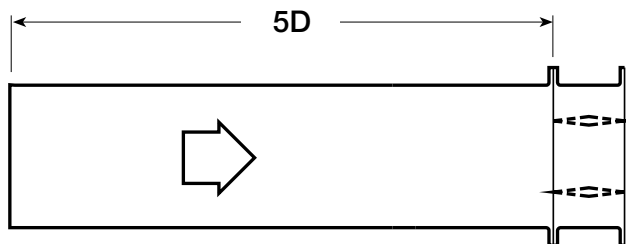

Figure 5.2

$$D = \sqrt{\frac{4(W)(H)}{3.14}}$$

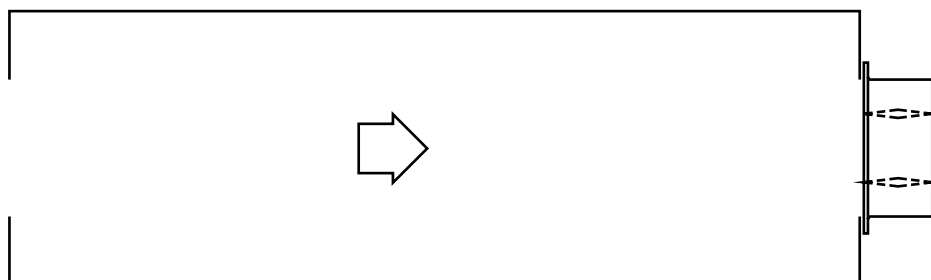
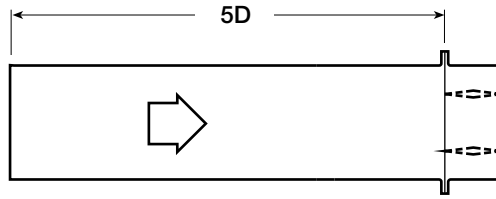

Figure 5.5

**AMCA Figure 5.2**



12 in. x 12 in. (305mm x 305mm)

Velocity (fpm)	Pressure Drop (in. wg)
500	0.03
1000	0.12
1500	0.26
2000	0.46
2500	0.72
3000	1.04
3500	1.41
4000	1.84

24 in. x 24 in. (610mm x 610mm)

Velocity (fpm)	Pressure Drop (in. wg)
500	0.01
1000	0.06
1500	0.12
2000	0.22
2500	0.34
3000	0.49
3500	0.67
4000	0.87

**AMCA Figure 5.3**

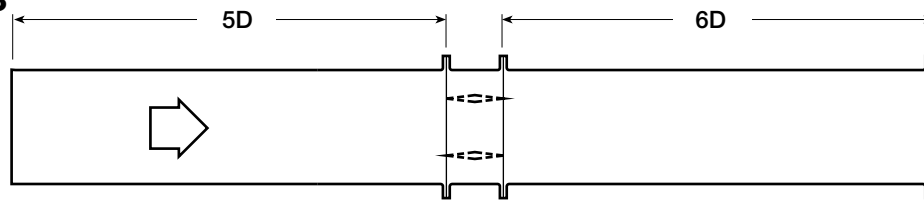

12 in. x 12 in. (305mm x 305mm)

Velocity (fpm)	Pressure Drop (in. wg)
500	0.01
1000	0.06
1500	0.13
2000	0.23
2500	0.37
3000	0.53
3500	0.73
4000	0.95

24 in. x 24 in. (610mm x 610mm)

Velocity (fpm)	Pressure Drop (in. wg)
500	0.01
1000	0.02
1500	0.06
2000	0.10
2500	0.16
3000	0.23
3500	0.32
4000	0.42

**AMCA Figure 5.5**

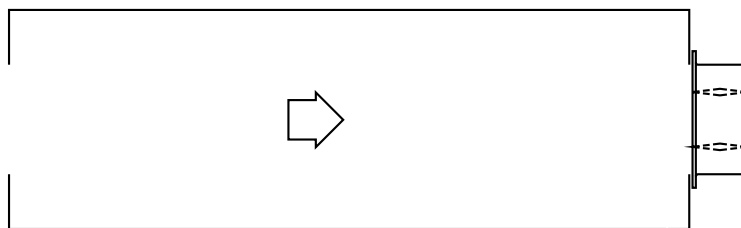

12 in. x 12 in. (305mm x 305mm)

Velocity (fpm)	Pressure Drop (in. wg)
500	0.04
1000	0.18
1500	0.42
2000	0.75
2500	1.17
3000	1.68
3500	2.29
4000	2.09

24 in. x 24 in. (610mm x 610mm)

Velocity (fpm)	Pressure Drop (in. wg)
500	0.03
1000	0.13
1500	0.29
2000	0.52
2500	0.81
3000	1.17
3500	1.60
4000	2.14

# Transitioned Damper Dimensions

When a fire/smoke damper is being used in conjunction with round or oval ductwork, the SMD-301V can be supplied in a factory sleeve with round or oval transitions on both ends of the sleeve. Dampers should be ordered to the duct dimensions. Drawings below show overall damper size.

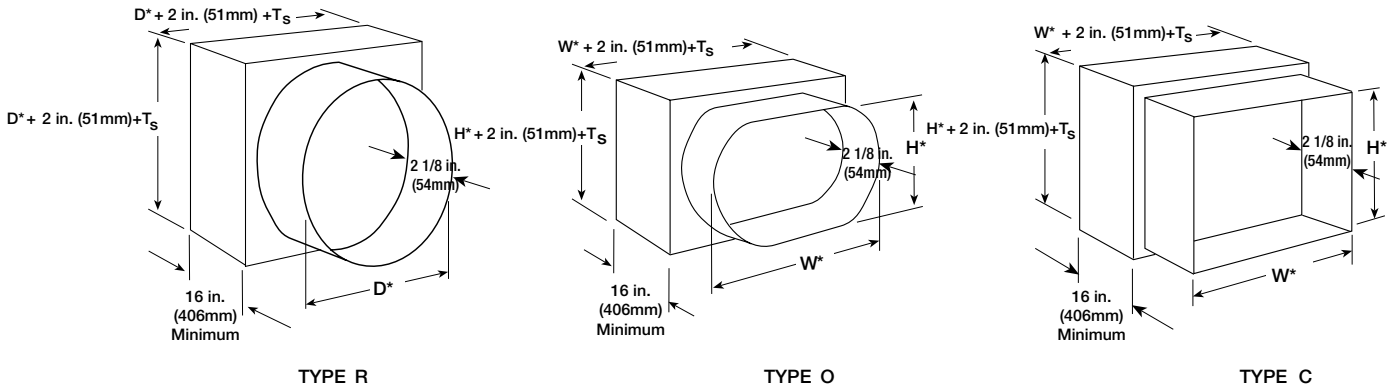

\* These dimensions are furnished approximately 1/4 in. (6mm) undersize, except round and oval dimensions which are approximately 1/8 in. (3mm) undersize.  
 $T_s = (2)(\text{Sleeve Thickness})$

## Specifications

Smoke Dampers meeting the following specifications shall be furnished and installed where shown on plans and/or as described in schedules. Dampers shall meet the requirements of NFPA 92A, 92B, 101 & 105 and shall be further tested, rated and labeled in accordance with the latest edition of UL Standard 555S. Smoke dampers shall be of low leakage design qualified to UL 555S Leakage Class I.

Each damper/actuator combination shall have a UL555S elevated temperature rating of 250°F (121° C) minimum and shall be rated to operate at maximum design air flow at its installed location. Each damper shall be supplied with an appropriate actuator installed by the damper manufacturer at the time of damper fabrication. Damper actuator shall be (specifier select one of the following) electric type for 120 (24 or 230) volt operation or pneumatic type for 25 psi minimum (30 psi maximum) operation.

Damper blades shall be of the double skin airfoil type and shall have an equivalent metal thickness of 14 ga.

(2mm) Damper frame shall be galvanized steel formed into a structural hat channel shape with reinforced corners. Bearings shall be 304 stainless steel sleeve type rotating in extruded holes in the damper frame. Blade edge seals shall be silicone rubber designed to inflate and provide a tighter seal against leakage as pressure on either side of the damper increases. Jamb seals shall be stainless steel compression type. Blades shall be completely symmetrical relative to their axle pivot point, presenting identical resistance to airflow in either direction or pressure on either side of the damper.

Damper must be rated for mounting vertically (with blades running vertical) and be UL 555S rated for leakage and air-flow in either direction through the damper.

The basis of design is Greenheck Model SMD-301V.

