

Application

Model SESMD-201 is a severe environment 316 stainless steel leakage rated smoke damper with 3V style blades. The SESMD-201 has been qualified to 2000 fpm (10.2 m/s) and 6 in. wg (1.5 kPa) for operational closure in emergency smoke control situations. Model SESMD-201 may be installed vertically (with blades running horizontally) or horizontally and is rated for airflow and leakage in either direction.

Ratings

Leakage Class:	I
Pressure:	6 in. wg (1.5 kPa) - differential pressure
Velocity:	Operational rated to 2000 fpm (10.2 m/s)
Temperature:	350°F (177°C) depending on the actuator.

Construction	Standard	Optional
Frame Material	316SS	-
Frame Material Thickness	16 ga. (1.5mm)	-
Frame Type	5 in. x 1 in. (127mm x 25mm) hat channel	Double Flange
Blade Material	316SS	-
Blade Material Thickness	16 ga. (1.5mm)	-
Blade Type	3V	-
Linkage	316SS out of airstream, concealed in jamb	-
Axle Bearings	316SS	-
Axle Material	316SS	-
Blade Seals	Silicone	-
Jamb Seals	316SS	-

Size Limitations

W x H	Minimum Size	Maximum Size	
		Single Section	Multiple Section
4 in. wg (1kPa) pressure			
Inches	8 x 6	32 x 50 or 36 x 48	144 x 100 or 288 x 50
mm	203 x 152	813 x 1270 or 914 x 1219	3658 x 2540 or 7315 x 1270
6 in. wg (1.5 kPa) pressure			
Inches	8 x 6	36 x 48	144 x 48
mm	203 x 152	914 x 1219	3658 x 1219

Features:

- Frames are constructed with reinforced corners. Low profile head and sill are used on sizes less than 17 in. high (432mm).
- Blades are reinforced with 3 longitudinal structurally designed vee's.
- Actuators: 120V, 24V, 230V, Pneumatic

Model SESMD-201 meets the requirements for smoke dampers established by:

National Fire Protection Association

NFPA Standards 92A, 92B, 101 & 105

IBC International Building Codes

New York City (MEA listing #260-91-M)

CSFM California State Fire Marshal

Leakage (Smoke) Damper Listing (#3230-0981:104)

"UL CLASSIFIED (see complete marking on product)"

"UL CLASSIFIED to Canadian safety standards (see complete marking on product)"

Standard 555S (Listing #R13317)

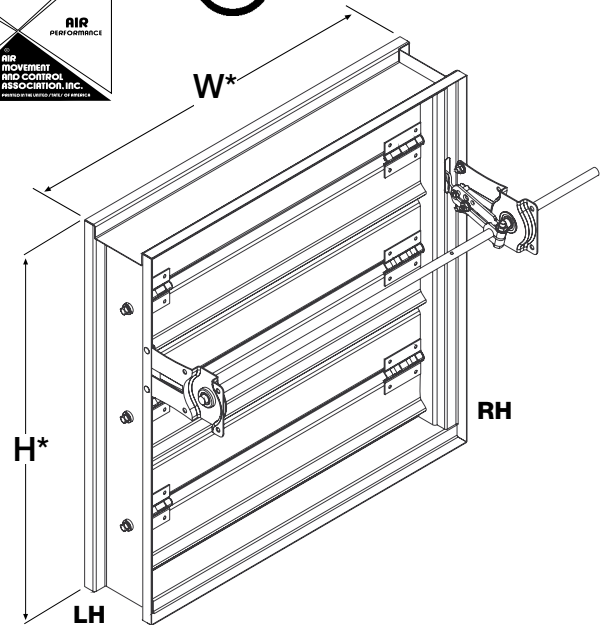

* W&H dimensions furnished approximately 1/4 in. (6mm) undersize. (Add sleeve thickness for overall sleeved damper dimension)
Right hand drive is shown. Left hand drive is available upon request.

OPTIONS:

- Factory mounted accessories
 - Retaining angles
- Greenheck test switches (GTS-3 & GTS-4)
- Momentary test switch
- POC retaining angles
- OCI (Open closed indication switches) - not 316SS
- Sealed transitions and sleeves
- Smoke detectors
- Transitions: R, C, O

This pressure drop testing was conducted in accordance with AMCA Standard 500-D using the three configurations shown. All data has been corrected to represent standard air at a density of .075 lb/ft³ (1.201 kg/m³).

Actual pressure drop found in any HVAC system is a combination of many factors. This pressure drop information along with an analysis of other system influences should be used to estimate actual pressure losses for a damper installed in a given HVAC system.

AMCA Test Figures

Figure 5.3 Illustrates a fully ducted damper. This configuration has the lowest pressure drop of the three test configurations because entrance and exit losses are minimized by straight duct runs upstream and downstream of the damper.

Figure 5.2 Illustrates a ducted damper exhausting air into an open area. This configuration has a lower pressure drop than Figure 5.5 because entrance losses are minimized by a straight duct run upstream of the damper.

Figure 5.5 Illustrates a plenum mounted damper. This configuration has the highest pressure drop because of extremely high entrance and exit losses due to the sudden changes of area in the system.

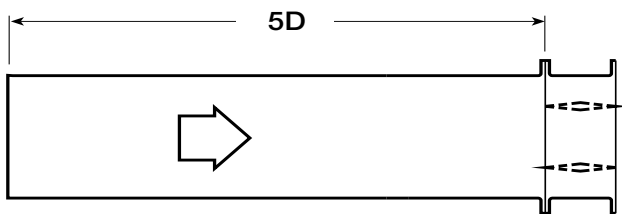
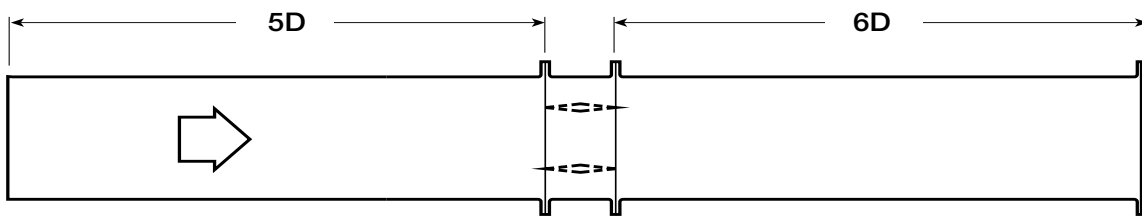

$$D = \sqrt{\frac{4(W)(H)}{3.14}}$$

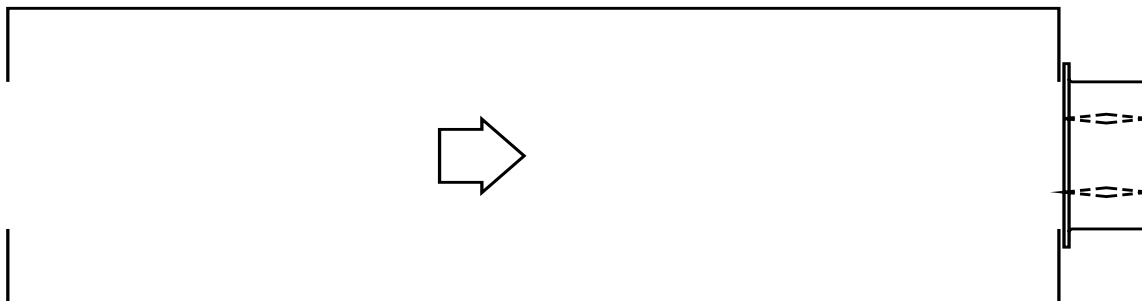

AMCA Figure 5.2

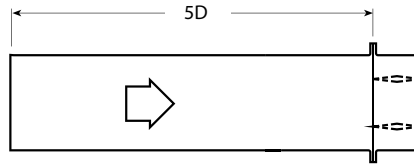

12 in. x 12 in. (305mm x 305mm)

Velocity (fpm)	Pressure Drop (in. wg)
500	0.04
1000	0.14
1500	0.31
2000	0.55
2500	0.86
3000	1.24
3500	1.69
4000	2.20

24 in. x 24 in. (610mm x 610mm)

Velocity (fpm)	Pressure Drop (in. wg)
500	0.02
1000	0.07
1500	0.16
2000	0.29
2500	0.45
3000	0.65
3500	0.89
4000	1.16

36 in. x 36 in. (914mm x 914mm)

Velocity (fpm)	Pressure Drop (in. wg)
500	0.01
1000	0.04
1500	0.09
2000	0.16
2500	0.25
3000	0.36
3500	0.49
4000	0.64

12 in. x 48 in. (305mm x 1219mm)

Velocity (fpm)	Pressure Drop (in. wg)
500	0.01
1000	0.06
1500	0.13
2000	0.23
2500	0.36
3000	0.52
3500	0.70
4000	0.92

48 in. x 12 in. (1219mm x 305mm)

Velocity (fpm)	Pressure Drop (in. wg)
500	0.03
1000	0.10
1500	0.23
2000	0.41
2500	0.63
3000	0.91
3500	1.24
4000	1.62

AMCA Figure 5.3

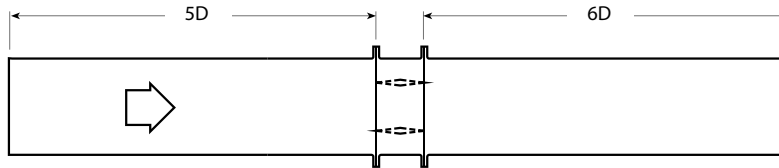

12 in. x 12 in. (305mm x 305mm)

Velocity (fpm)	Pressure Drop (in. wg)
500	0.02
1000	0.09
1500	0.20
2000	0.36
2500	0.56
3000	0.81
3500	1.10
4000	1.44

24 in. x 24 in. (610mm x 610mm)

Velocity (fpm)	Pressure Drop (in. wg)
500	0.01
1000	0.04
1500	0.09
2000	0.16
2500	0.25
3000	0.35
3500	0.48
4000	0.63

36 in. x 36 in. (914mm x 914mm)

Velocity (fpm)	Pressure Drop (in. wg)
500	0.01
1000	0.03
1500	0.06
2000	0.11
2500	0.17
3000	0.24
3500	0.33
4000	0.42

12 in. x 48 in. (305mm x 1219mm)

Velocity (fpm)	Pressure Drop (in. wg)
500	0.01
1000	0.04
1500	0.10
2000	0.17
2500	0.27
3000	0.39
3500	0.53
4000	0.70

48 in. x 12 in. (1219mm x 305mm)

Velocity (fpm)	Pressure Drop (in. wg)
500	0.02
1000	0.07
1500	0.16
2000	0.29
2500	0.45
3000	0.64
3500	0.88
4000	1.14

AMCA Figure 5.5

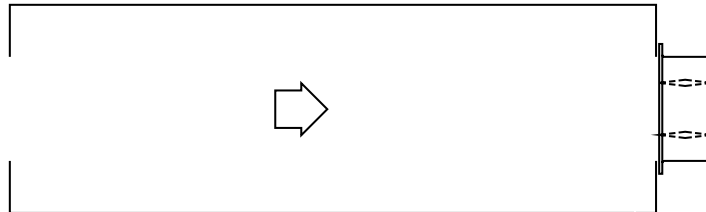

12 in. x 12 in. (305mm x 305mm)

Velocity (fpm)	Pressure Drop (in. wg)
500	0.06
1000	0.22
1500	0.50
2000	0.89
2500	1.39
3000	2.00
3500	2.72
4000	3.55

24 in. x 24 in. (610mm x 610mm)

Velocity (fpm)	Pressure Drop (in. wg)
500	0.03
1000	0.14
1500	0.31
2000	0.54
2500	0.85
3000	1.22
3500	1.66
4000	2.17

36 in. x 36 in. (914mm x 914mm)

Velocity (fpm)	Pressure Drop (in. wg)
500	0.03
1000	0.12
1500	0.26
2000	0.46
2500	0.73
3000	1.05
3500	1.42
4000	1.86

12 in. x 48 in. (305mm x 1219mm)

Velocity (fpm)	Pressure Drop (in. wg)
500	0.03
1000	0.13
1500	0.30
2000	0.53
2500	0.83
3000	1.19
3500	1.62
4000	2.11

48 in. x 12 in. (1219mm x 305mm)

Velocity (fpm)	Pressure Drop (in. wg)
500	0.04
1000	0.17
1500	0.38
2000	0.67
2500	1.04
3000	1.50
3500	2.05
4000	2.67



Greenheck Fan Corporation certifies that the model SESMD-201 shown herein is licensed to bear the AMCA Seal. The ratings shown are based on tests and procedures performed in accordance with AMCA Publication 511 and comply with the requirements of the AMCA Certified Ratings Programs. The AMCA Certified Ratings Seal applies to air performance ratings only.

Actuators and Accessories

Space Envelopes

Externally mounted actuators always require space outside of the damper sleeve. The “S” dimension illustrates the clearance required for various available actuators.

On dampers less than 18 in. (457mm) high, actuators may also require clearances above and/or below the sleeve. “B” and “T” dimensions are **worst** case clearance requirements for some dampers less than 18 in. (457mm) high. All damper sizes under 18 in. (457mm) high do not require these worst case clearances. If space availability above or below the damper sleeve is limited, each damper size should be individually evaluated.

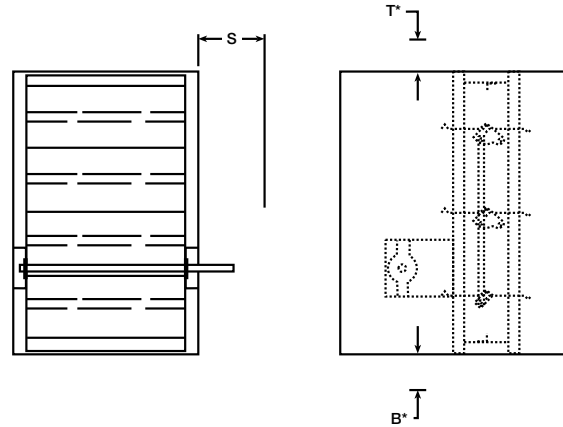

Actuator Type/Model	B*	T*	S	
	With RRL, RRL/OCI, or TOR	With RRL, RRL/OCI, or TOR	PiggyBack	
			No	Yes
120 Volt AC				
FSLF120 (-S) Belimo	3 1/2 in. (89mm)	0	6 in. (152mm)	NA
FSNF120 (-S) Belimo	12 3/4 in. (324mm)	0	6 in. (152mm)	9 in. (229mm)
FSTF120 (-S) Belimo	3 1/2 in. (89mm)	0	6 in. (152mm)	NA
ML4XXX Series Honeywell	4 3/4 in. (121mm)	0	6 in. (152mm)	NA
MS4X09 Series Honeywell	4 3/4 in. (121mm)	0	6 in. (152mm)	NA
MS4120 Series Honeywell	12 3/4 in. (324mm)	0	6 in. (152mm)	9 in. (229mm)
GND-22X.1 Siemens	12 3/4 in. (324mm)	0	6 in. (152mm)	NA
24 Volt AC				
FSAF24 (-S) Belimo	12 3/4 in. (324mm)	0	6 in. (152mm)	NA
FSAF24-BAL (-S) Belimo	12 3/4 in. (324mm)	0	6 in. (152mm)	NA
FSLF24 (-S) Belimo	3 1/2 in. (89mm)	0	6 in. (152mm)	NA
FSNF24 (-S) Belimo	12 3/4 in. (324mm)	0	6 in. (152mm)	9 in. (229mm)
ML8XXX Series Honeywell	4 3/4 in. (121mm)	0	6 in. (152mm)	NA
MS8X09 Series Honeywell	4 3/4 in. (121mm)	0	6 in. (152mm)	NA
MS8120 Series Honeywell	12 3/4 in. (324mm)	0	6 in. (152mm)	9 in. (229mm)
GND-12X.1 Siemens	12 3/4 in. (324mm)	0	6 in. (152mm)	NA
230 Volt AC				
FSLF230 (-S) Belimo	3 1/2 in. (89mm)	0	6 in. (152mm)	NA
FSNF230 (-S) Belimo	12 3/4 in. (324mm)	0	6 in. (152mm)	9 in. (229mm)
ML4XXX Series Honeywell	4 3/4 in. (121mm)	0	6 in. (152mm)	NA
MS4X09 Series Honeywell	4 3/4 in. (121mm)	0	6 in. (152mm)	NA
MS4620 Series Honeywell	12 3/4 in. (324mm)	0	6 in. (152mm)	9 in. (229mm)
GND 321.1 Siemens	12 3/4 in. (324mm)	0	6 in. (152mm)	NA
Pneumatic (25 psi min.)				
331-4551 Siemens	7 1/2 in. (191mm)	0	6 in. (152mm)	NA
331-2976 Siemens	12 3/4 in. (324mm)	0	6 in. (152mm)	NA
331-2856 Siemens	2 1/2 in. (64mm)	0	9 in. (229mm)	NA
MK2-7121 TAC (Invensys)	2 1/2 in. (64mm)	0	9 in. (229mm)	NA

* For dampers 18 in. (457mm) or more in height these dimensions are 0 in. .

Damper Sideplate and Sleeve Dimensional Data

The drawings below illustrate the factory standard sideplate and sleeve mountings for the SESMD-201. The standard "A" dimensions listed in the table provide adequate space for the mounting of actuators and controls.

If space constraints are a problem the "A" dimension can be varied between 5 3/8 in. (136mm) and 12 in. (305mm).

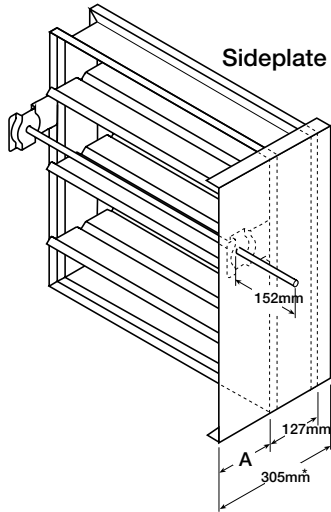

in. (mm)	"A" Dimension	
	Standard	Maximum
All Dampers*	7 3/16 in. (183)	12 (305)
When Height is 11 in. (279) or less with OCI	12 (305)	12 (305)

*With the exception of dampers 10 in. high (254mm) or less.
NOTE: Entire damper frame is not required to be installed within the wall.

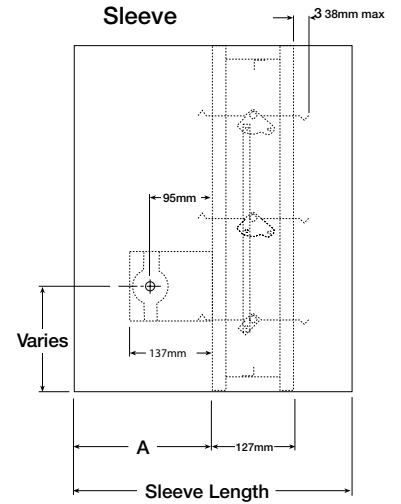

Damper Sizing Information

Dampers larger than maximum single section size are supplied as a factory assembly of two or more sections of equal size.

The following figures show damper sections and assemblies that have been qualified for operation with a single actuator. Larger sizes can be accommodated using multiples of these assemblies.

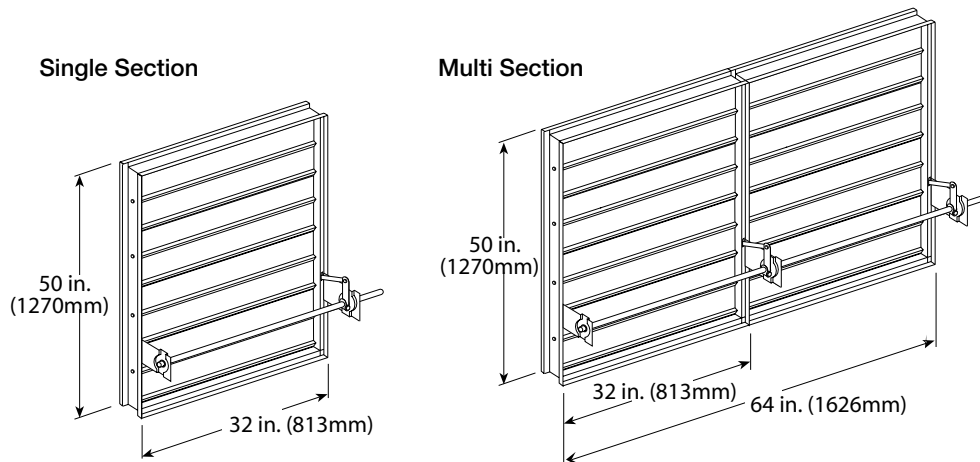

Transitioned Damper Dimensions

When a fire/smoke damper is being used in conjunction with round or oval ductwork, the SESMD-201 can be supplied in a factory sleeve with round or oval transitions on both ends of the sleeve. Dampers should be ordered to the duct dimensions. Drawings below show overall damper size.

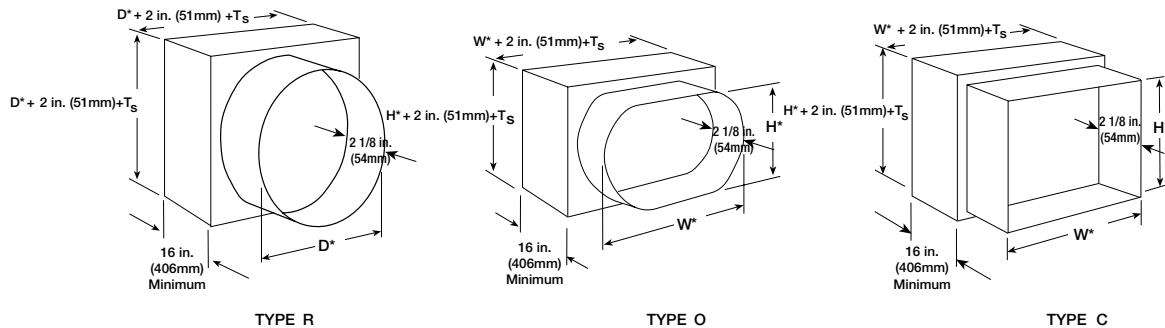

* These dimensions are furnished approximately 1/4 in. (6mm) undersize, except round and oval dimensions which are approximately 1/8 in. (3mm) undersize.
 $T_s = (2)(\text{Sleeve Thickness})$

Specifications

Smoke Dampers meeting the following specifications shall be furnished and installed where shown on plans and/or as described in schedules. Dampers shall meet the requirements of NFPA 92A, 92B, 101 & 105 and further shall be tested, rated and labeled in accordance with the latest edition of UL Standards 555S. Dampers shall be UL labeled for use in dynamic systems.

Dampers shall have a UL555S leakage rating of Class I and a temperature rating of 250°F (121°C). Dampers shall have a UL555S operational airflow rating equal to or greater than the airflow at its installed location and an operational pressure rating up to 6 in. wg (1.5 kPa). Damper actuators shall be factory mounted and qualified for use with the damper in accordance with UL555S. Damper actuators shall be (specifier select one of the following) electric type for 120V, 24V, 230 volt operation or pneumatic type for 25 psi minimum (30 psi maximum) operation. Manufacturer's submittal data shall indicate actuator space requirements around the damper.

Damper blades shall be 16 ga. (1.5mm) 316 stainless steel 3V type with three longitudinal grooves for reinforcement. Blades shall be

completely symmetrical relative to their axle pivot point, presenting identical resistance to airflow and operation in either direction through the damper (blades that are non-symmetrical relative to their axle pivot point or utilize blade stops larger than 0.5 in. are unacceptable).

Damper frames shall be 16 ga. (1.5mm) 316 stainless steel formed into a structural hat channel shape with reinforced corners. Bearings shall be stainless steel type rotating in extruded holes in the damper frame. Jamb seals shall be stainless steel compression type.

The Damper manufacturer's submittal data shall certify all air performance pressure drop data is licensed in accordance with the AMCA certified ratings program for test figures 5.2, 5.3, and 5.5. Damper air performance shall be developed in accordance with the latest edition of AMCA Standard 500-D.

The basis of design is Greenheck's model SESMD-201.

