



Model SEFSD-211

Application

Model SEFSD-211 is a severe environment 316SS combination fire smoke damper with 3V style blades. The SEFSD-211 has been qualified to 2000 fpm (10.2 m/s) and 6 in. wg (1.5 kPa) for operation and dynamic closure in emergency fire smoke situations. Model SEFSD-211 may be installed vertically (with blades running horizontal) or horizontally and is rated for airflow and leakage in either direction.

Combination FIRE SMOKE DAMPERS

316 Stainless Steel 3V Blades

UL 555S Leakage Class I

UL555 1 1/2 Hour Fire Resistance Rating

Ratings

UL 555 Fire Resistance Rating

Fire Rating: 1 1/2 Hours
Dynamic Closure Rating: Actual limits are size dependant
Maximum Velocity: 2000 fpm (10.2 m/s)
Maximum Pressure: 6 in. wg (1.5 kPa)

UL 555S Leakage Rating

Leakage Class: I
Operational Rating: Actual limits are actuator dependant
Maximum Velocity: 2000 fpm (10.2 m/s)
Maximum Pressure: 6 in. wg (1.5 kPa)
Maximum Temperature: 350°F (177°C) — Depending on actuator

Model SEFSD-211 meets the requirements for fire dampers, smoke dampers and combination fire smoke dampers established by:

National Fire Protection Association

NFPA Standards 80, 90A, 92A, 92B 101 & 105

IBC International Building Codes

New York City (MEA listing #260-91-M)

California State Fire Marshall

Listing #: 3225-0981:103 (fire)

Listing #: 3230-0981:104 (smoke)

“UL CLASSIFIED (see complete marking on product)”

“UL CLASSIFIED to Canadian safety standards (see complete marking on product)”

Standard 555 & 555S (Listing #R13317)

Construction	Standard	Optional
Frame Material	316SS	-
Frame Material Thickness	16 ga. (1.5mm)	-
Frame Type	5 in. x 1in. (127mm x 25mm) hat channel	-
Blade Material	316SS	-
Blade Material Thickness	16 ga. (1.5mm)	-
Blade Type	3V	-
Linkage	316SS out of airstream, concealed in jamb	-
Axle Bearings	316SS	-
Axle Material	316SS	-
Blade Seals	Silicone	-
Jamb Seals	316SS	-
Closure Device	RRL	RRL/OCI, TOR, PRV, or Fusible Link
Closure Temperature	165°F (74°C)	212°F (100°C), 250°F (121°C), 350°F (177°C)

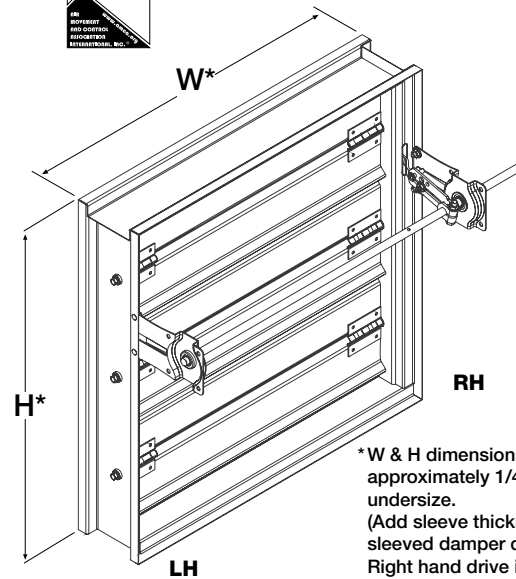

*W & H dimensions furnished approximately 1/4 in. (6mm) undersize.
 (Add sleeve thickness for overall sleeved damper dimension)
 Right hand drive is shown. Left hand drive is available upon request.

W x H	Minimum Size	Maximum Size		
		Single Section	Multiple Section	
			Horizontal	Vertical
4 in. wg (1 kPa) pressure				
Inches	8 x 6	24 x 30 or 22 x 36	48 x 30	88 x 72
mm	203 x 152	610 x 762 or 559 x 914	1219 x 762	2235 x 1829
6 in. wg (1.5 kPa)				
Inches	8 x 6	24 x 30	48 x 30	88 x 30
mm	203 x 152	610 x 762	1219 x 762	2235 x 762

FEATURES:

- Frames are constructed with reinforced corners. Low profile head and sill are used on sizes less than 17 in. high (432mm).
- Blades are reinforced with 3 longitudinal structurally designed vee's.

Installation instructions available at www.greenheck.com

Options available on SEFSD-211:

- Actuators: 120V, 24V, 230V, pneumatic
- Factory mounted accessories
 - Retaining angles
- Greenheck test switches (GTS-1, -2, -3, -4)
- Momentary test switch
- POC retaining angles
- RRL/OCI (Open closed indication switches)
- TOR (Temperature limited override)
- Sealed transitions and sleeves
- Smoke detectors
- Transitions: R, C, O

Pressure Drop Data

This pressure drop testing was conducted in accordance with AMCA Standard 500-D using the three configurations shown. All data has been corrected to represent standard air at a density of .075 lb/ft³ (1.201 kg/m³).

Actual pressure drop found in any HVAC system is a combination of many factors. This pressure drop information along with an analysis of other system influences should be used to estimate actual pressure losses for a damper installed in a given HVAC system.

AMCA Test Figures

Figure 5.3 Illustrates a fully ducted damper. This configuration has the lowest pressure drop of the three test configurations because entrance and exit losses are minimized by straight duct runs upstream and downstream of the damper.

Figure 5.2 Illustrates a ducted damper exhausting air into an open area. This configuration has a lower pressure drop than Figure 5.5 because entrance losses are minimized by a straight duct run upstream of the damper.

Figure 5.5 Illustrates a plenum mounted damper. This configuration has the highest pressure drop because of extremely high entrance and exit losses due to the sudden changes of area in the system.

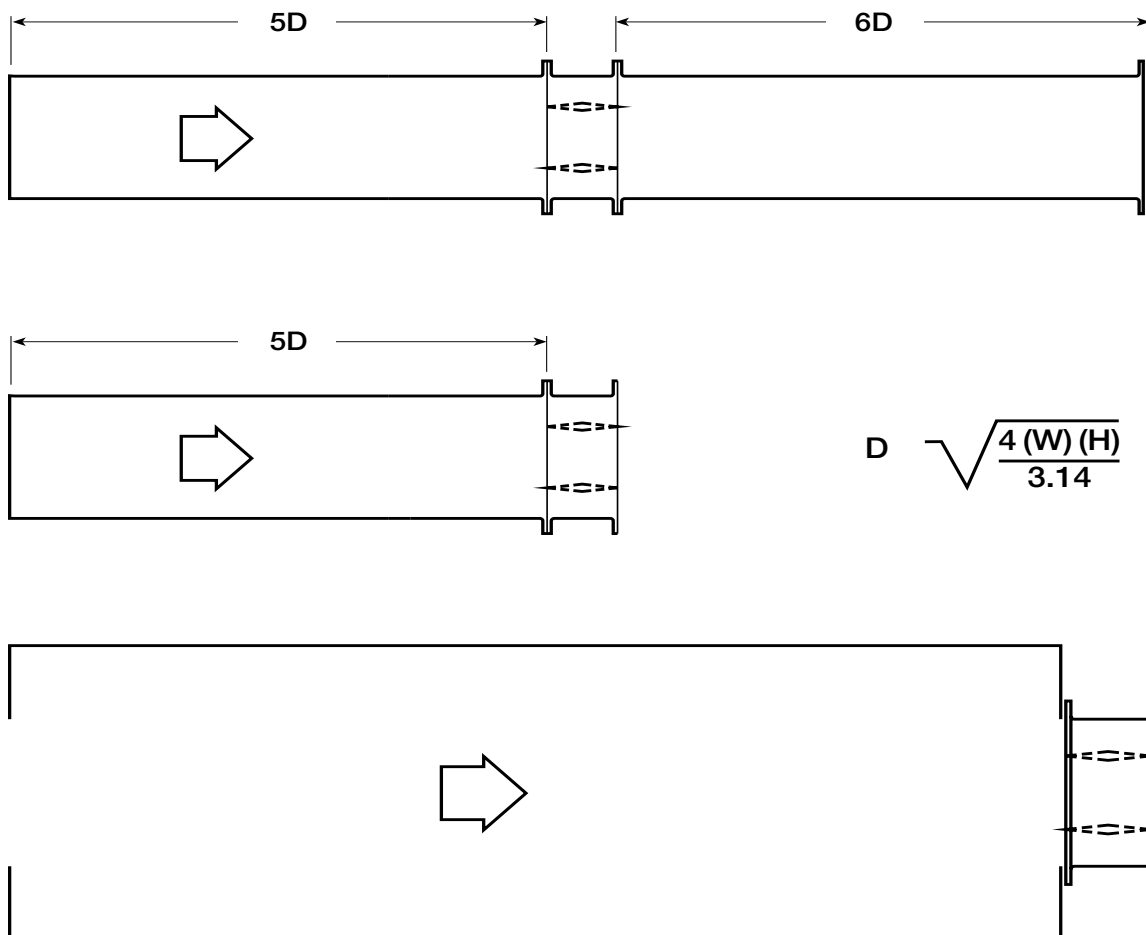

AMCA Figure 5.2

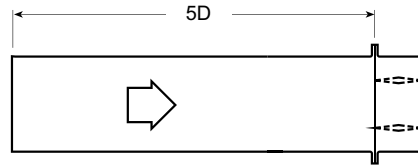

12 in. x 12 in. (305mm x 305mm)

Velocity (fpm)	Pressure Drop (in. wg)
500	0.04
1000	0.14
1500	0.31
2000	0.55
2500	0.86
3000	1.24
3500	1.69
4000	2.20

24 in. x 24 in. (610mm x 610mm)

Velocity (fpm)	Pressure Drop (in. wg)
500	0.02
1000	0.07
1500	0.16
2000	0.29
2500	0.45
3000	0.65
3500	0.89
4000	1.16

36 in. x 36 in. (914mm x 914mm)

Velocity (fpm)	Pressure Drop (in. wg)
500	0.01
1000	0.04
1500	0.09
2000	0.16
2500	0.25
3000	0.36
3500	0.49
4000	0.64

12 in. x 48 in. (305mm x 1219mm)

Velocity (fpm)	Pressure Drop (in. wg)
500	0.01
1000	0.06
1500	0.13
2000	0.23
2500	0.36
3000	0.52
3500	0.70
4000	0.92

48 in. x 12 in. (1219mm x 305mm)

Velocity (fpm)	Pressure Drop (in. wg)
500	0.03
1000	0.10
1500	0.23
2000	0.41
2500	0.63
3000	0.91
3500	1.24
4000	1.62

AMCA Figure 5.3

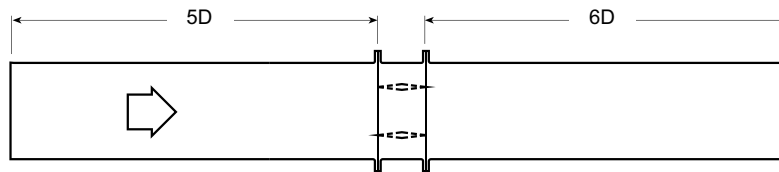

12 in. x 12 in. (305mm x 305mm)

Velocity (fpm)	Pressure Drop (in. wg)
500	0.02
1000	0.09
1500	0.20
2000	0.36
2500	0.56
3000	0.81
3500	1.10
4000	1.44

24 in. x 24 in. (610mm x 610mm)

Velocity (fpm)	Pressure Drop (in. wg)
500	0.01
1000	0.04
1500	0.09
2000	0.16
2500	0.25
3000	0.35
3500	0.48
4000	0.63

36 in. x 36 in. (914mm x 914mm)

Velocity (fpm)	Pressure Drop (in. wg)
500	0.01
1000	0.03
1500	0.06
2000	0.11
2500	0.17
3000	0.24
3500	0.33
4000	0.42

12 in. x 48 in. (305mm x 1219mm)

Velocity (fpm)	Pressure Drop (in. wg)
500	0.01
1000	0.04
1500	0.10
2000	0.17
2500	0.27
3000	0.39
3500	0.53
4000	0.70

48 in. x 12 in. (1219mm x 305mm)

Velocity (fpm)	Pressure Drop (in. wg)
500	0.02
1000	0.07
1500	0.16
2000	0.29
2500	0.45
3000	0.64
3500	0.88
4000	1.14

AMCA Figure 5.5

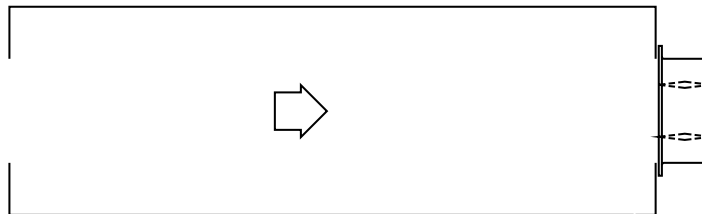

12 in. x 12 in. (305mm x 305mm)

Velocity (fpm)	Pressure Drop (in. wg)
500	0.06
1000	0.22
1500	0.50
2000	0.89
2500	1.39
3000	2.00
3500	2.72
4000	3.55

24 in. x 24 in. (610mm x 610mm)

Velocity (fpm)	Pressure Drop (in. wg)
500	0.03
1000	0.14
1500	0.31
2000	0.54
2500	0.85
3000	1.22
3500	1.66
4000	2.17

36 in. x 36 in. (914mm x 914mm)

Velocity (fpm)	Pressure Drop (in. wg)
500	0.03
1000	0.12
1500	0.26
2000	0.46
2500	0.73
3000	1.05
3500	1.42
4000	1.86

12 in. x 48 in. (305mm x 1219mm)

Velocity (fpm)	Pressure Drop (in. wg)
500	0.03
1000	0.13
1500	0.30
2000	0.53
2500	0.83
3000	1.19
3500	1.62
4000	2.11

48 in. x 12 in. (1219mm x 305mm)

Velocity (fpm)	Pressure Drop (in. wg)
500	0.04
1000	0.17
1500	0.38
2000	0.67
2500	1.04
3000	1.50
3500	2.05
4000	2.67



Greenheck Fan Corporation certifies that the model SEFSD-211 shown herein is licensed to bear the AMCA Seal. The ratings shown are based on tests and procedures performed in accordance with AMCA Publication 511 and comply with the requirements of the AMCA Certified Ratings Programs. The AMCA Certified Ratings Seal applies to air performance ratings only.

Actuators and Accessories

Space Envelopes

Externally mounted actuators always require space outside of the damper sleeve. The “S” dimension illustrates the clearance required for various available actuators.

On dampers less than 18 in. (457mm) high, actuators may also require clearances above and/or below the sleeve. “B” and “T” dimensions are **worst** case clearance requirements for some dampers less than 18 in. (457mm) high. All damper sizes under 18 in. (457mm) high do not require these worst case clearances. If space availability above or below the damper sleeve is limited, each damper size should be individually evaluated.

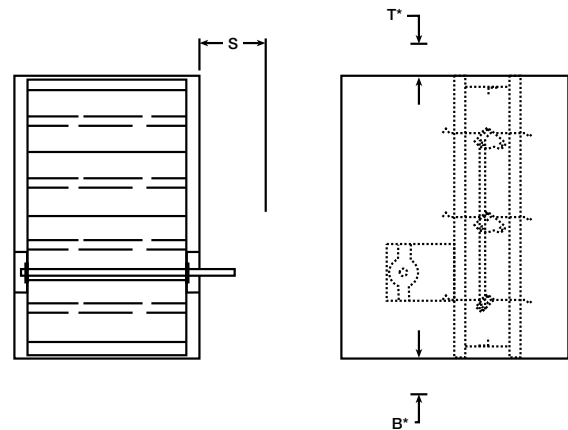

Actuator Type/Model	B*	T*	S	
	With RRL, RRL/OCI, or TOR	With RRL, RRL/OCI, or TOR	PiggyBack	
			No	Yes
120 Volt AC				
FSLF120 (-S) Belimo	3 1/2 in. (89mm)	0	6 in. (152mm)	NA
FSNF120 (-S) Belimo	12 3/4 in. (324mm)	0	6 in. (152mm)	9 in. (229mm)
FSTF120 (-S) Belimo	3 1/2 in. (89mm)	0	6 in. (152mm)	NA
ML4XXX Series Honeywell	4 3/4 in. (121mm)	0	6 in. (152mm)	NA
MS4X09 Series Honeywell	4 3/4 in. (121mm)	0	6 in. (152mm)	NA
MS4120 Series Honeywell	12 3/4 in. (324mm)	0	6 in. (152mm)	9 in. (229mm)
GND-22X.1 Siemens	12 3/4 in. (324mm)	0	6 in. (152mm)	NA
24 Volt AC				
FSAF24 (-S) Belimo	12 3/4 in. (324mm)	0	6 in. (152mm)	NA
FSAF24-BAL (-S) Belimo	12 3/4 in. (324mm)	0	6 in. (152mm)	NA
FSLF24 (-S) Belimo	3 1/2 in. (89mm)	0	6 in. (152mm)	NA
FSNF24 (-S) Belimo	12 3/4 in. (324mm)	0	6 in. (152mm)	9 in. (229mm)
ML8XXX Series Honeywell	4 3/4 in. (121mm)	0	6 in. (152mm)	NA
MS8X09 Series Honeywell	4 3/4 in. (121mm)	0	6 in. (152mm)	NA
MS8120 Series Honeywell	12 3/4 in. (324mm)	0	6 in. (152mm)	9 in. (229mm)
GND-12X.1 Siemens	12 3/4 in. (324mm)	0	6 in. (152mm)	NA
230 Volt AC				
FSLF230 (-S) Belimo	3 1/2 in. (89mm)	0	6 in. (152mm)	NA
FSNF230 (-S) Belimo	12 3/4 in. (324mm)	0	6 in. (152mm)	9 in. (229mm)
ML4XXX Series Honeywell	4 3/4 in. (121mm)	0	6 in. (152mm)	NA
MS4X09 Series Honeywell	4 3/4 in. (121mm)	0	6 in. (152mm)	NA
MS4620 Series Honeywell	12 3/4 in. (324mm)	0	6 in. (152mm)	9 in. (229mm)
GND 321.1 Siemens	12 3/4 in. (324mm)	0	6 in. (152mm)	NA
Pneumatic (25 psi min.)				
331-4551 Siemens	7 1/2 in. (191mm)	0	6 in. (152mm)	NA
331-2976 Siemens	12 3/4 in. (324mm)	0	6 in. (152mm)	NA
331-2856 Siemens	2 1/2 in. (64mm)	0	9 in. (229mm)	NA
MK2-7121 TAC (Invensys)	2 1/2 in. (64mm)	0	9 in. (229mm)	NA

* For dampers 18 in. (457mm) or more in height these dimensions are 0 in. .

Damper Sleeve Dimensional Data

The drawings below and corresponding table show the position of the SSFSD-211 damper when mounted in a factory sleeve. The standard mounting locations provide enough space for the mounting of actuators, controls and allow space for installation of retaining angles and duct connections.

The standard location of a damper mounted in a factory sleeve ("A" dimension) is shown below. The damper can be positioned at other locations within a range of 6 in. (152mm) to 12 in. (305mm) for the "A" dimension.

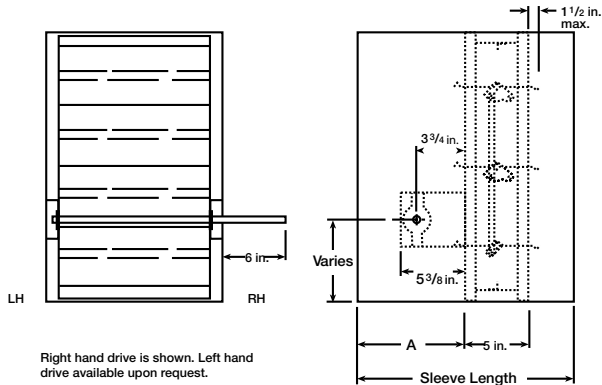

in. (mm)	"A" Dimension	
	Standard	Maximum
All Dampers*	7 3/16 (183)	12 (305)
When H is 11 in. (279mm) or less with OCI, RRL, or TOR	12 (305)	12 (305)

*With the exception of dampers 10 in. high (254mm) or less.
 NOTE: Entire damper frame is not required to be installed within the wall. The damper blades, when closed should be contained within the wall.

Damper Sizing Information

Dampers larger than maximum single section size are supplied as a factory assembly of two or more sections of equal size. The following figures show maximum damper section size and assembly configurations for multi-section dampers.

Single Section

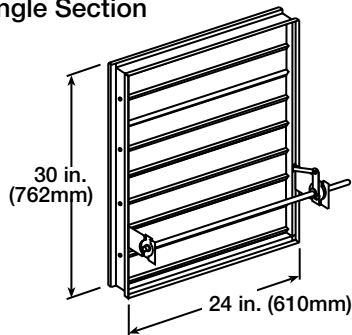

Double Section

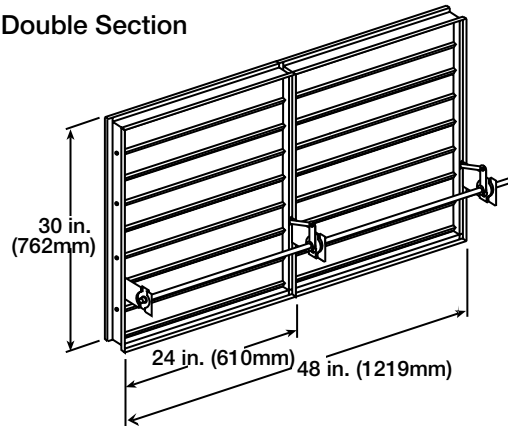

Transitioned Damper Dimensions

When a fire/smoke damper is being used in conjunction with round or oval ductwork, the SEFSD-211 can be supplied in a factory sleeve with round or oval transitions on both ends of the sleeve. Dampers should be ordered to the duct dimensions. Drawings below show overall damper size.

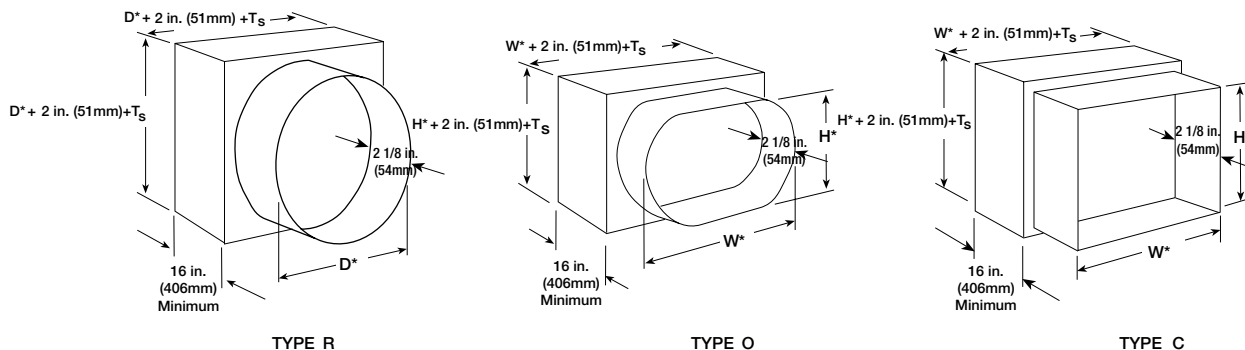

* These dimensions are furnished approximately 1/4 in. (6mm) undersize, except round and oval dimensions which are approximately 1/8 in. (3mm) undersize.

$T_S = (2)(\text{Sleeve Thickness})$

Specifications

Combination Fire Smoke Dampers meeting the following specifications shall be furnished and installed where shown on plans and/or as described in schedules. Dampers shall meet the requirements of the latest edition of NFPA 80, 90A, 92A, 92B, 101, & 105 and further shall be tested in accordance with the latest edition of UL Standards 555 and 555S. Dampers shall have a UL 555 fire rating of 1 1/2 hours and be of low leakage design qualified to UL555S leakage class I.

Each damper/actuator combination shall have a UL555S elevated temperature rating of 250°F (121°C) minimum and shall be operational and dynamic rated to operate at maximum design air flow at its installed location. Each damper shall be supplied with an appropriate actuator installed by the damper manufacturer at the time of damper fabrication. Damper actuator shall be (specifier select one of the following) electric type for 120 (24 or 230) volt operation or pneumatic type for 25 psi minimum (30 psi maximum) operation.

The Damper Manufacturers submittal data shall certify all air performance pressure drop data is licensed in accordance with the AMCA Certified Ratings Program for Test Figures 5.2, 5.3 and 5.5. Damper air performance data shall be developed in accordance with

the latest edition of AMCA Standard 500-D. Dampers shall be labeled with the AMCA Air Performance Seal.

Damper blades shall be 16 ga. (1.5mm) 316 stainless steel 3V type with three longitudinal grooves for reinforcement. Blades shall be completely symmetrical relative to their axle pivot point, presenting identical resistance to airflow and operation in either direction through the damper (blades that are non-symmetrical relative to their axle pivot point or utilize blade stops larger than 1/2 in. [13mm] are unacceptable). Damper frames shall be 316 stainless steel formed into a structural hat channel shape with reinforced corners. Bearings shall be 316 stainless steel sleeve type rotating in extruded holes in the damper frame. Jamb seals shall be stainless steel compression type.

All UL 555 and 555S Dynamic Closure Ratings, Operational Ratings and Leakage Ratings shall be qualified for airflow and pressure in either direction through the damper. UL ratings shall allow for mounting damper vertically (with blades running horizontal) or horizontally.

Basis of design is Greenheck Model SEFSD-211.

