



Model SEDFD-210

Multi-Blade Fire Damper

Stainless Steel 3-V Blades

UL555 1 1/2 Hour Fire Resistance Rating

Application

Model SEDFD-210 is a severe environment 316 stainless steel multi-blade fire damper with 3 Vee style blades. The SEDFD-210 has been qualified to 2000 fpm (10.2 m/s) and 4 in. wg. (1 kPa) for dynamic closure in emergency fire situations. Model SEDFD-210 may be installed vertically (with blades running horizontal) or horizontally and is rated for airflow in either direction.

Ratings

UL 555 Fire Resistance Rating

Fire Rating: 1 1/2 Hours
Dynamic Closure Rating: Actual limits are size dependent
Maximum Velocity: 2000 fpm (10.2 m/s)
Maximum Pressure: 4 in. wg (1 kPa)



Model SEDFD-210 is intended for installation in accordance with fire damper requirements established by:

National Fire Protection Association
 NFPA Standards 80, 90A & 101

ICBO Uniform Building Codes

IBC International Building Codes

CSFM California State Fire Marshal
 Fire Damper Listing (#3225-0981:103)

"UL CLASSIFIED (see complete marking on product)"
"UL CLASSIFIED to Canadian safety standards (see complete marking on product)"
 Standard 555 (Listing #R13317)

Construction	Standard	Optional
Frame Material	316SS	-
Frame Material Thickness	16 ga. (1.5mm)	-
Frame Type	5 in. x 1in. (127mm x 25mm) hat channel	-
Blade Material	316SS	-
Blade Material Thickness	16 ga. (1.5mm)	-
Blade Type	3V	-
Linkage	316SS out of air-stream, concealed in jamb	-
Axle Bearings	316SS	-
Axle Material	316SS	-
Jamb Seals	316SS	-
Closure Device	Fusible link - not 316SS	-
Closure Temperature	165°F (74°C)	212°F (100°C), 286°F (141°C), 350°F (177°C)
Actuator	316SS Manual quadrant	-

W x H	Minimum Size	Maximum Size	
		Single Section	Multi-Section
Inches	8 x 6	24 x 30	48 x 30
mm	203 x 152	610 x 762	1219 x 762



Greenheck Fan Corporation certifies that the model SEDFD-210 shown herein is licensed to bear the AMCA Seal. The ratings shown are based on tests and procedures performed in accordance with AMCA Publication 511 and comply with the requirements of the AMCA Certified Ratings Programs. The AMCA Certified Ratings Seal applies to air performance ratings only.

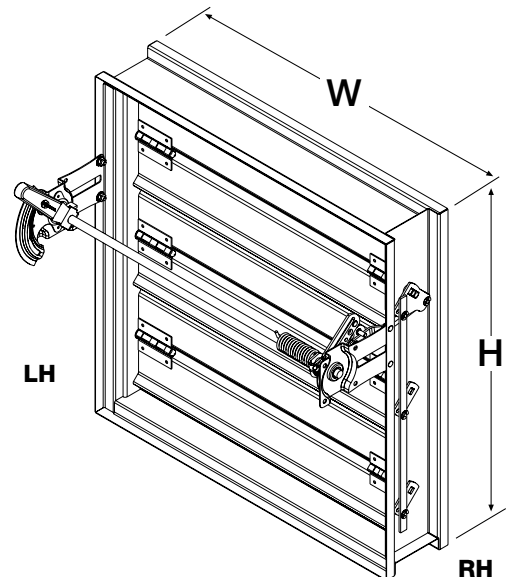

*W & H dimensions furnished approximately 1/4 in. (6mm) undersize. (Add sleeve thickness for overall sleeved damper dimension)

Options

- Extra Fusible Links
- Factory Installed Accessories
 - Retaining Angles
- Flanges
- OCI (Open Closed Indication switches)
- POC retaining angles
- Sealed transition and sleeves
- Sleeves
- Smoke Detector
- Transitions (R, C, O)

Features

- Frames are constructed with reinforced corners. Low profile head and sill are used on sizes less than 17 in. (432mm) high.
- Blades are reinforced with 3 longitudinal structurally designed vee's.

Installation instructions available at www.greenheck.com

This pressure drop testing was conducted in accordance with AMCA Standard 500-D using the three configurations shown. All data has been corrected to represent standard air at a density of .075 lb/ft³(1.201 kg/m³).

Actual pressure drop found in any HVAC system is a combination of many factors. This pressure drop information along with an analysis of other system influences should be used to estimate actual pressure losses for a damper installed in a given HVAC system.

AMCA Test Figures

Figure 5.3 Illustrates a fully ducted damper. This configuration has the lowest pressure drop of the three test configurations because entrance and exit losses are minimized by straight duct runs upstream and downstream of the damper.

Figure 5.2 Illustrates a ducted damper exhausting air into an open area. This configuration has a lower pressure drop than Figure 5.5 because entrance losses are minimized by a straight duct run upstream of the damper.

Figure 5.5 Illustrates a plenum mounted damper. This configuration has the highest pressure drop because of extremely high entrance and exit losses due to the sudden changes of area in the system.

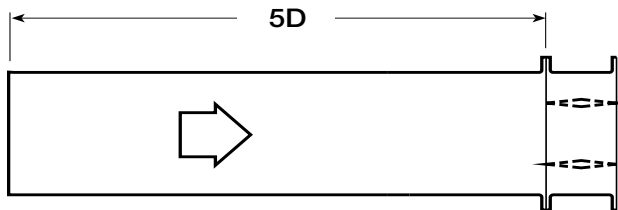
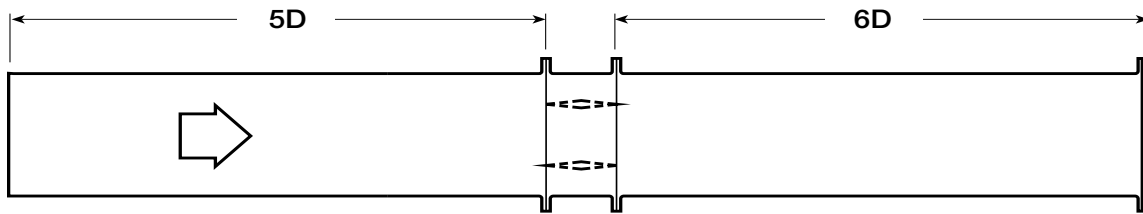

$$D = \sqrt{\frac{4(W)(H)}{3.14}}$$

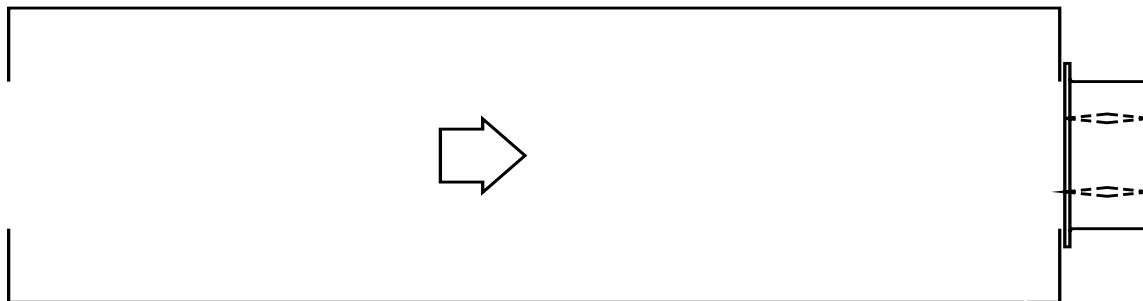

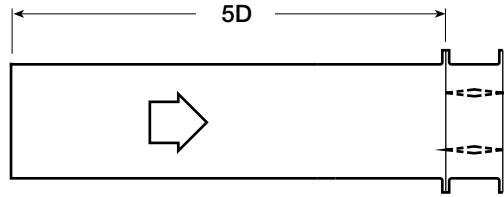

VELOCITY VS. PRESSURE DROP

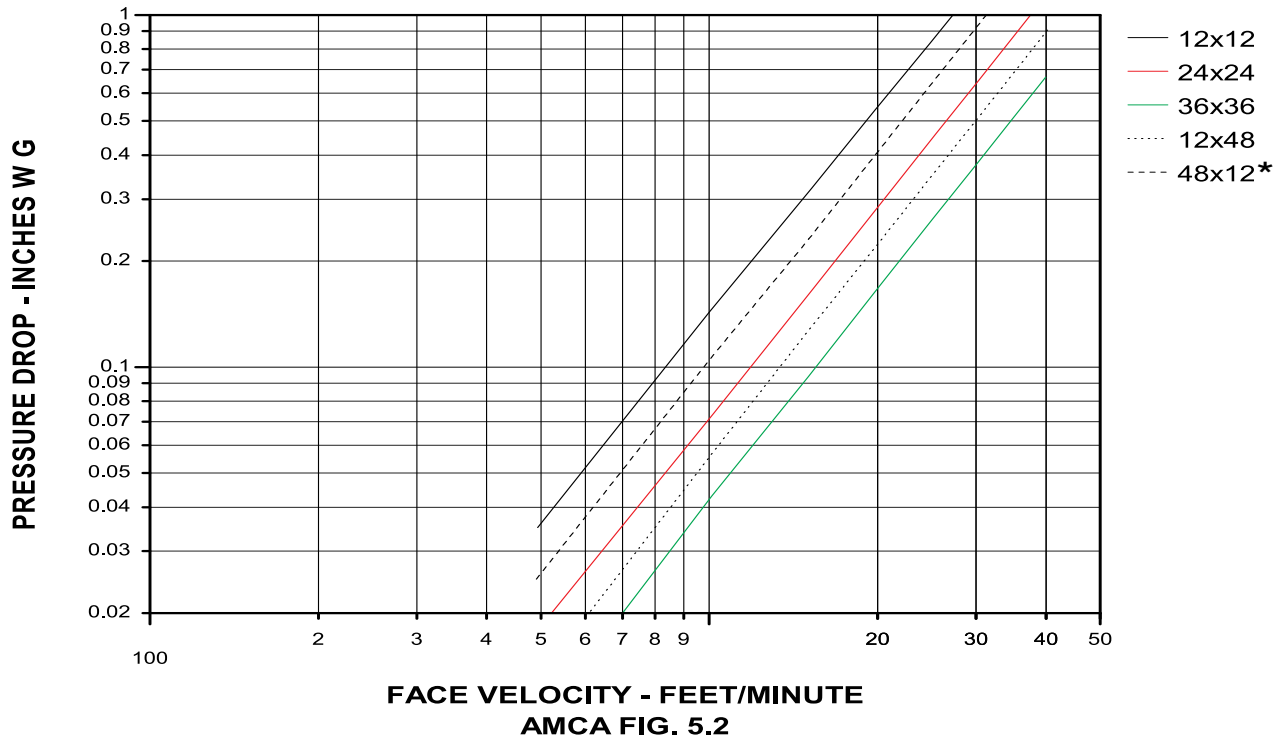

FACE VELOCITY - FEET/MINUTE
AMCA FIG. 5.2

12 in. x 12 in. (305mm x 305mm)

Velocity (fpm)	Pressure Drop (in. wg)
500	0.04
1000	0.14
1500	0.31
2000	0.55
2500	0.86
3000	1.24
3500	1.69
4000	2.20

24 in. x 24 in. (610mm x 610mm)

Velocity (fpm)	Pressure Drop (in. wg)
500	0.02
1000	0.07
1500	0.16
2000	0.29
2500	0.45
3000	0.65
3500	0.89
4000	1.16

36 in. x 36 in. (914mm x 914mm)

Velocity (fpm)	Pressure Drop (in. wg)
500	0.01
1000	0.04
1500	0.09
2000	0.16
2500	0.25
3000	0.36
3500	0.49
4000	0.64

12 in. x 48 in. (305mm x 1219mm)

Velocity (fpm)	Pressure Drop (in. wg)
500	0.01
1000	0.06
1500	0.13
2000	0.23
2500	0.36
3000	0.52
3500	0.70
4000	0.92

48 in. x 12 in. (1219mm x 305mm)

Velocity (fpm)	Pressure Drop (in. wg)
500	0.03
1000	0.10
1500	0.23
2000	0.41
2500	0.63
3000	0.91
3500	1.24
4000	1.62



Greenheck Fan Corporation certifies that the model SEDFD-210 shown herein is licensed to bear the AMCA Seal. The ratings shown are based on tests and procedures performed in accordance with AMCA Publication 511 and comply with the requirements of the AMCA Certified Ratings Programs. The AMCA Certified Ratings Seal applies to air performance ratings only.

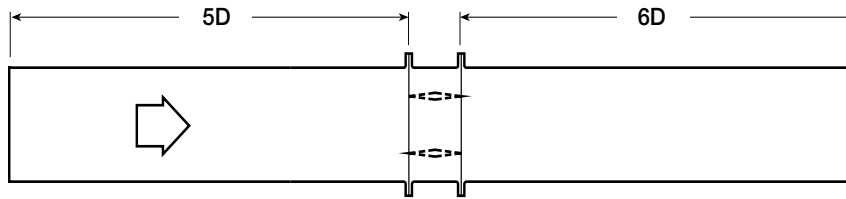

VELOCITY VS. PRESSURE DROP

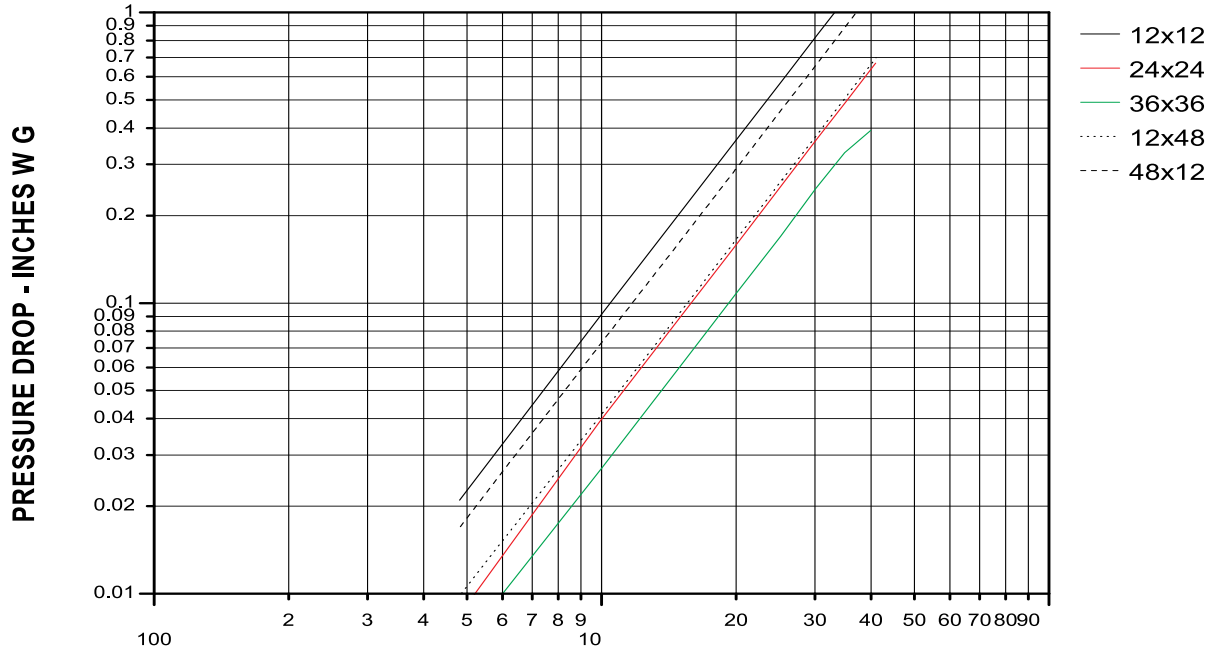

FACE VELOCITY - FEET/MINUTE
AMCA FIG. 5.3

12 in. x 12 in. (305mm x 305mm)

Velocity (fpm)	Pressure Drop (in. wg)
500	0.02
1000	0.09
1500	0.20
2000	0.36
2500	0.56
3000	0.81
3500	1.10
4000	1.44

24 in. x 24 in. (610mm x 610mm)

Velocity (fpm)	Pressure Drop (in. wg)
500	0.01
1000	0.04
1500	0.09
2000	0.16
2500	0.25
3000	0.35
3500	0.48
4000	0.63

36 in. x 36 in. (914mm x 914mm)

Velocity (fpm)	Pressure Drop (in. wg)
500	0.01
1000	0.03
1500	0.06
2000	0.11
2500	0.17
3000	0.24
3500	0.33
4000	0.42

12 in. x 48 in. (305mm x 1219mm)

Velocity (fpm)	Pressure Drop (in. wg)
500	0.01
1000	0.04
1500	0.10
2000	0.17
2500	0.27
3000	0.39
3500	0.53
4000	0.70

48 in. x 12 in. (1219mm x 305mm)

Velocity (fpm)	Pressure Drop (in. wg)
500	0.02
1000	0.07
1500	0.16
2000	0.29
2500	0.45
3000	0.64
3500	0.88
4000	1.14



Greenheck Fan Corporation certifies that the model SEDFD-210 shown herein is licensed to bear the AMCA Seal. The ratings shown are based on tests and procedures performed in accordance with AMCA Publication 511 and comply with the requirements of the AMCA Certified Ratings Programs. The AMCA Certified Ratings Seal applies to air performance ratings only.

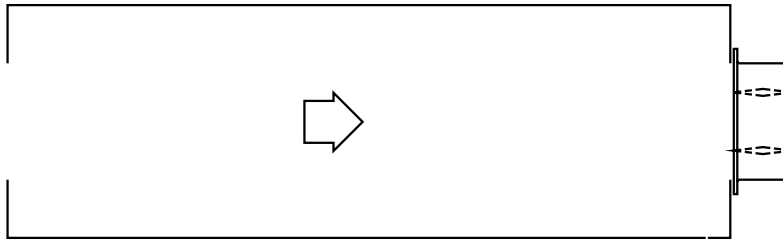

VELOCITY VS. PRESSURE DROP

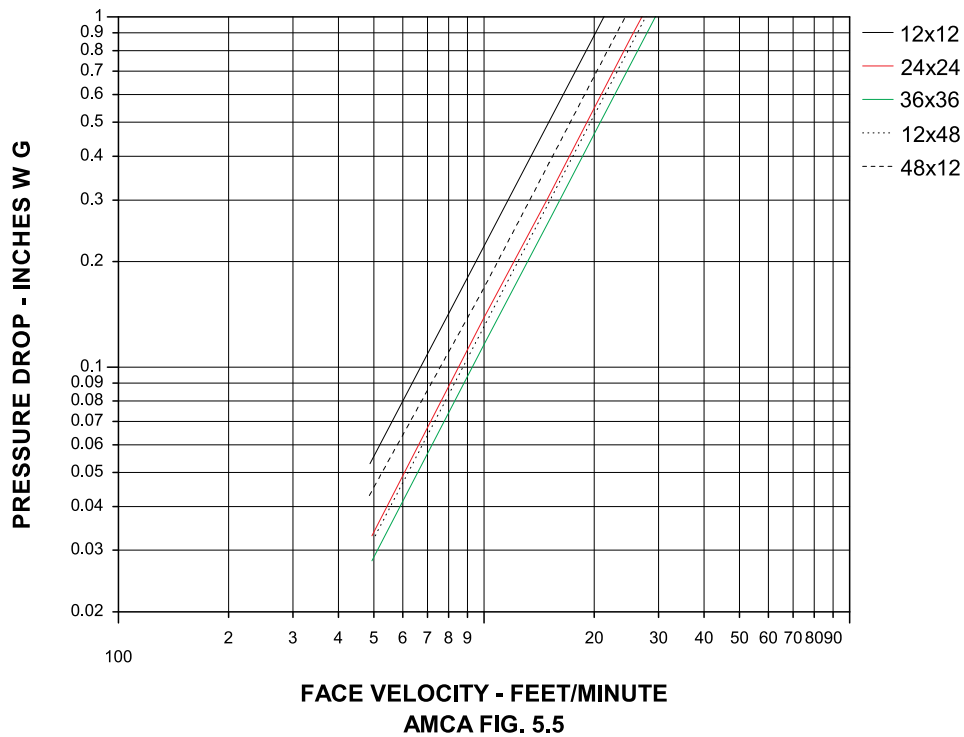

12 in. x 12 in. (305mm x 305mm)

Velocity (fpm)	Pressure Drop (in. wg)
500	0.06
1000	0.22
1500	0.50
2000	0.89
2500	1.39
3000	2.00
3500	2.72
4000	3.55

24 in. x 24 in. (610mm x 610mm)

Velocity (fpm)	Pressure Drop (in. wg)
500	0.03
1000	0.14
1500	0.31
2000	0.54
2500	0.85
3000	1.22
3500	1.66
4000	2.17

36 in. x 36 in. (914mm x 914mm)

Velocity (fpm)	Pressure Drop (in. wg)
500	0.03
1000	0.12
1500	0.26
2000	0.46
2500	0.73
3000	1.05
3500	1.42
4000	1.86

12 in. x 48 in. (305mm x 1219mm)

Velocity (fpm)	Pressure Drop (in. wg)
500	0.03
1000	0.13
1500	0.30
2000	0.53
2500	0.83
3000	1.19
3500	1.62
4000	2.11

48 in. x 12 in. (1219mm x 305mm)

Velocity (fpm)	Pressure Drop (in. wg)
500	0.04
1000	0.17
1500	0.38
2000	0.67
2500	1.04
3000	1.50
3500	2.05
4000	2.67



Greenheck Fan Corporation certifies that the model SEDFD-210 shown herein is licensed to bear the AMCA Seal. The ratings shown are based on tests and procedures performed in accordance with AMCA Publication 511 and comply with the requirements of the AMCA Certified Ratings Programs. The AMCA Certified Ratings Seal applies to air performance ratings only.

Damper Sizing Information

Dampers larger than maximum single section size are supplied as a factory assembly of two or more sections of equal size. The following figures show maximum damper section size and assembly configurations for multi-section dampers.

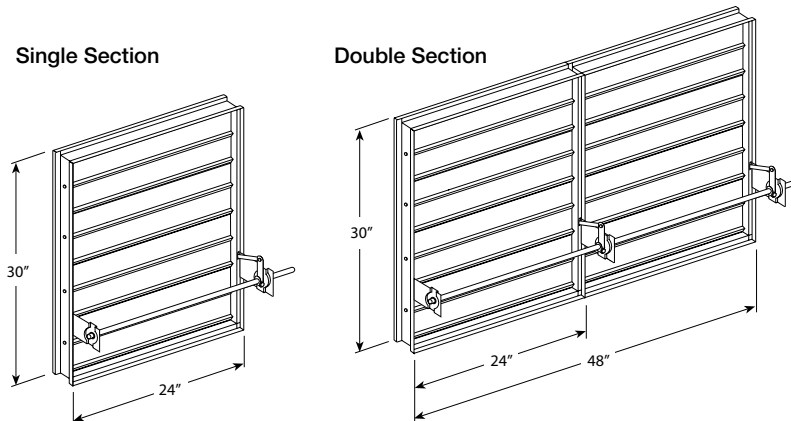

All dimensions shown are in inches.

Damper Sleeve Dimensional Data

The drawings below and corresponding table show the position of the SEDFD-210 damper when mounted in a factory sleeve. The standard mounting locations provide enough space for the mounting of manual quadrant, controls and allow space for installation of retaining angles and duct connections.

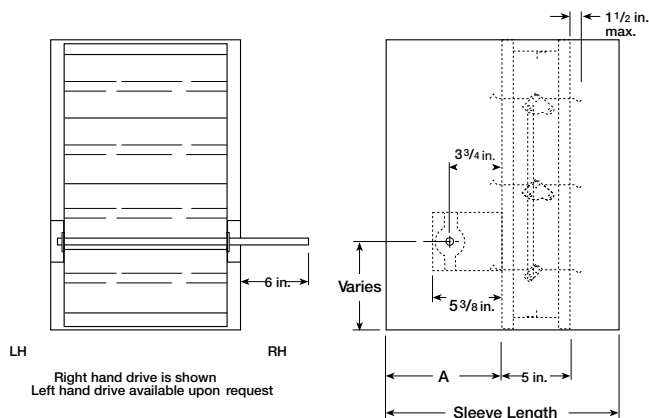

All dimensions shown are in inches.

The "A" dimension is the location of the damper mounted in a factory sleeve. The table below shows the Standard and Maximum "A" dimensions.

in. (mm)	"A" Dimension	
	Standard	Minimum
All Dampers	7 3/16 (183)	12 (305)
When H is 10 in. (254mm) or less with OCI	12 (305)	12 (305)

*With the exception of dampers 10 in. high (254mm) or less.
NOTE: Entire damper frame is not required to be installed within the wall. The damper blades, when closed should be contained within the wall.

Specifications

Fire Dampers meeting the following specifications shall be furnished and installed where shown on plans and/or as described in schedules. Dampers shall meet the requirements of the latest edition of NFPA 80, 90A & 101.

Dampers shall be tested, rated and labeled in accordance with the latest edition of UL Standard 555. Dampers shall have a UL 555 fire rating of 1 1/2 hours. Each damper shall be equipped with a heat responsive device which has been tested and approved for use with the damper assembly in accordance with UL 555. The heat responsive device shall have a temperature rating of (specifier select one of the following) 165°F (74°C), 212°F (100°C), 286°F (121°C), or 350°F (177°C). Dampers shall be UL labeled for use in dynamic systems. The damper shall have a dynamic closure pressure rating of 4 in. wg (1 kPa).

Damper actuator shall be 316 stainless steel manual quadrant. Manufacturers submittal data shall indicate actuator space requirements around the damper.

UL 555 Dynamic Closure Ratings shall be qualified for airflow and pressure in either direction through the damper. UL ratings shall allow for mounting damper vertically (with blades running horizontal) or horizontally.

The Damper Manufacturers submittal data shall certify all air performance pressure drop data is licensed in accordance with the AMCA Certified Ratings

Program for Test Figures 5.2, 5.3 and 5.5. Damper air performance data shall be developed in accordance with the latest edition of AMCA Standard 500-D.

Dampers shall be listed by the California State Fire Marshal.

Damper blades shall be 16 gauge (1.5mm) 316 stainless steel 3 Vee type with three longitudinal grooves for reinforcement. Blades shall be completely symmetrical relative to their axle pivot point, presenting identical resistance to airflow and operation in either direction through the damper (blades that are non-symmetrical relative to their axle pivot point or utilize blade stops larger than 1/2 in. [13mm] are unacceptable).

Damper frame shall be 16 ga. (1.5mm) 316 stainless steel formed into a structural hat channel shape with reinforced corners. Bearings shall be 316 stainless steel sleeve type rotating in extruded holes in the damper frame. Axles shall be square and positively locked into the damper blade. Jamb seals shall be stainless steel compression type.

Basis of design is Greenheck Model SEDFD-210.



P.O. Box 410 • Schofield, WI 54476-0410 • 715.359.6171 • greenheck.com

Copyright © 2009 Greenheck Fan Corporation

SEDFD-210 Rev. 4 April 2009