

## Penthouse Elevator Vent

### Application and Design

The PEV-400 Penthouse Elevator Vent is a gravity ventilator penthouse with three sides fabricated of Greenheck's ESJ-401 stationary louver model. A smoke damper with a 120 volt actuator and OCI (Open Closed Indicator) is located in the throat of the unit. The unit is shop assembled and shipped attached to the curb with the damper installed in the curb.

### Standard Construction

#### Louvered

**Perimeters.** . . . . Heavy gauge extruded 6063-T5 aluminum,  
4 in. x 0.081 in. nominal wall thickness

**Birdscreen.** . . . . 3/4 in. x 0.051 in. flattened expanded aluminum in removable frame, inside mount (rear)

**Finish.** . . . . . Mill

**Size** . . . . . 38 in. x 38 in. x 18 in., sits on a standard 36 in. high curb or optional 12 in. or 24 in. high curb

**Curb** . . . . . 12 ga. cold rolled steel, 4 in. mounting flange, welded construction, permatector paint finish

**Hood** . . . . . 0.100 formed aluminum with 0.5 in. insulation

**Boxed Corner** . . 0.100 formed aluminum

**Glass** . . . . . 0.125 in. annealed clear

**Weight.** . . . . . 495 pounds (with curb)

**Roof Opening** . . 38 in. x 38 in.

#### Louver

**Model** . . . . . ESJ-401

**Size** . . . . . 30 in. x 18 in. (3 total)

**Free Area.** . . . . 4.44 sq. ft. (total)

#### Damper

**Model** . . . . . SMD-202

**Size** . . . . . 26 in. x 26 in.

**Actuator** . . . . . 120V, GGD, Fail open

**Free Area.** . . . . 3.071 sq. ft.

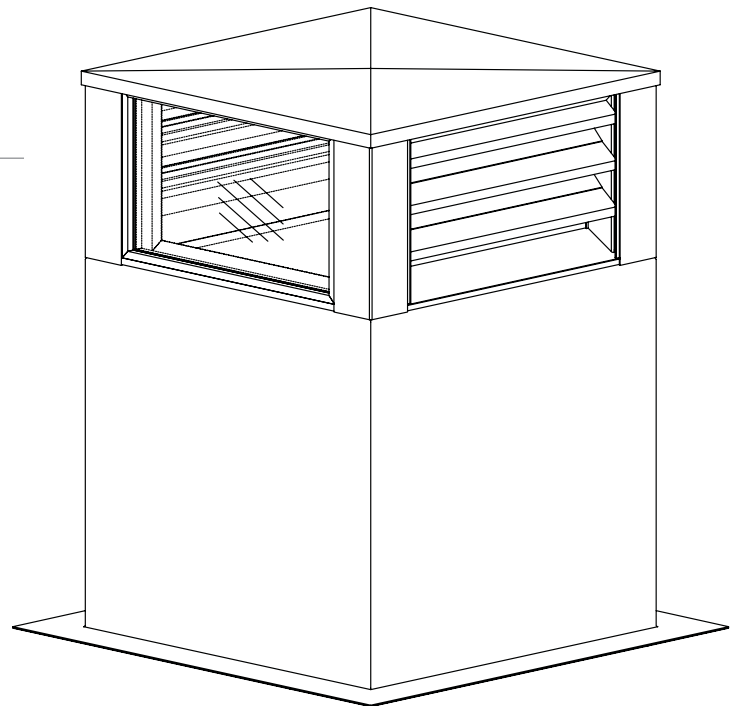

### Options (at additional cost)

- A variety of bird and insect screens
- A variety of architectural finishes including:
  - Clear anodize
  - Integral color anodize
  - Baked enamel paint
  - Kynar paint

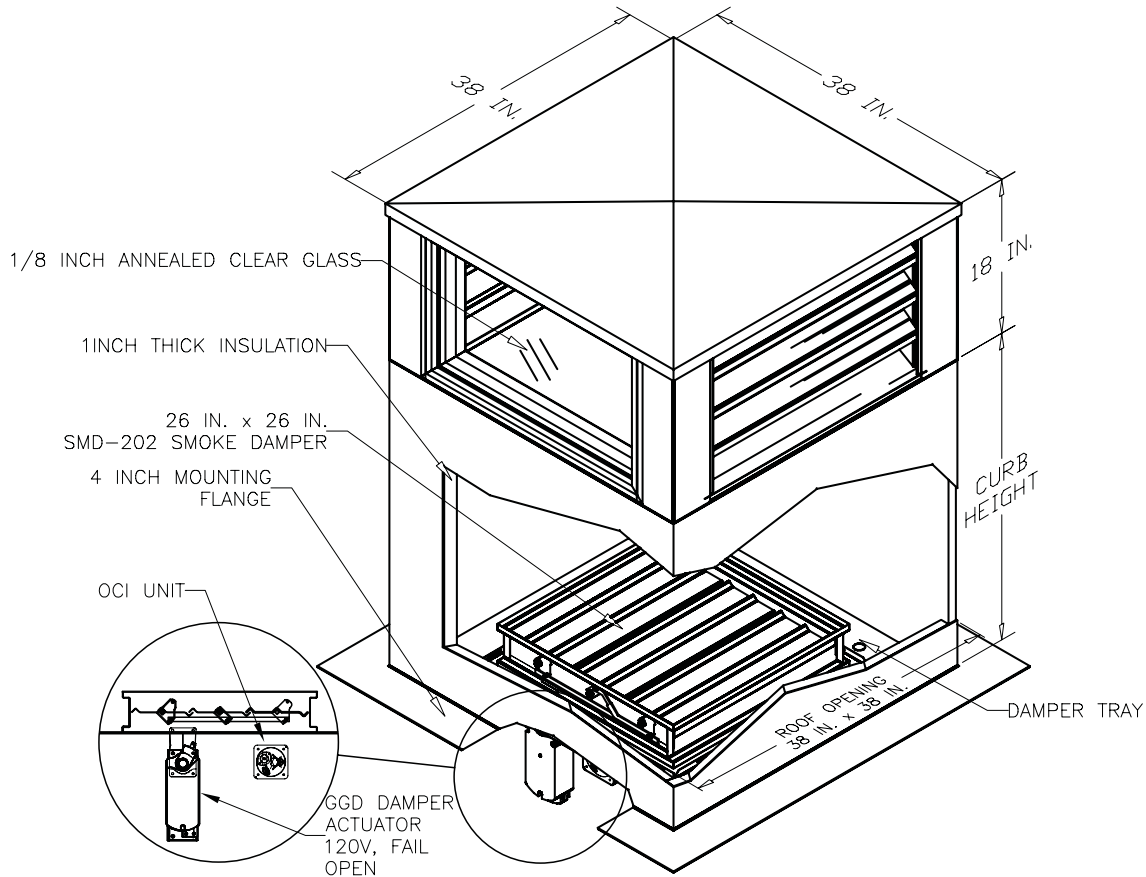

## FINISHES

Finish Type	Description/Application	Color Selection	Standard Warranty (Aluminum)
2-coat 70% KYNAR 5000®/HYLAR 5000® AAMA 2605 – Dry film thickness 1.2 mil. (AKA: Duranar®, Fluoropon®, Trinar®, Flouropolymer, Polyvinylidene Fluoride, PVDF2)	<b>“Best.”</b> The premier finish for extruded aluminum. Tough, long-lasting coating has superior color retention and abrasive properties. Resists chalking, fading, chemical abrasion and weathering.	<b>Standard Colors:</b> Any of the 24 standard colors shown can be furnished in 70% or 50% KYNAR 5000®/HYLAR 5000® or Baked Enamel.  <b>2-Coat Mica:</b> Greenheck offers 9 standard 2-coat Mica colors. Other colors are available. Consult Greenheck for possible extra cost when selecting non-standard colors or special finishes.	10 Years (Consult Greenheck for availability of extended warranty)
2-coat 50% KYNAR 5000®/HYLAR 5000® AAMA 2604 – Dry film thickness 1.2 mil. (AKA: Acroflur®, Acrynar®)	<b>“Better.”</b> Tough, long-lasting coating has excellent color retention and abrasive properties. Resists chalking, fading, chemical abrasion and weathering.		5 Years
Baked Enamel AAMA 2603 – Dry film thickness 0.8 mil. (AKA: Acrabond Plus®, Duracron®)	<b>“Good.”</b> Provides good adhesion and resistance to weathering, corrosion and chemical stain.		1 Year
Integral Color Anodize AA-M10C22A42 (>0.7 mil)	“Two-step” anodizing is produced by following the normal anodizing step with a second, colorfast process.	Medium or Dark Bronze	5 years
Clear Anodize 204 R-1 AA-M10C22A31 (0.4-0.7 mil)	Clear, colorless and hard oxide aluminum coating that resists weathering and chemical attack.	Clear	1 Year
Industrial coatings	Greenheck offers a number of industrial coatings such as Hi-Pro Polyester, Epoxy, and Permatector®. Consult a Greenheck Product Specialist for complete color and application information.		Consult Greenheck
Mill	Materials may be supplied in natural aluminum or galvanized steel finish when normal weathering is acceptable and there is no concern for color or color change.		n/a

Finishes meet or exceed AAMA 2605, AAMA 2604, and AAMA 2603 requirements. Please consult [www.greenheck.com](http://www.greenheck.com) for complete information on standard and extended paint warranties. Paint finish warranties are not applicable to steel products.

