

Purpose/Application

National and local safety standards and codes recognize the ability of air duct systems to transfer smoke, toxic gases, and flame from area to area. Sometimes smoke can be of such quantity as to be a serious hazard to life safety unless blowers are shut down and dampers are actuated. The primary purpose of duct smoke detection is to prevent injury, panic, and property damage by reducing the spread (recirculation) of smoke. The detector samples air currents passing through a duct and gives dependable performance for management of smoke and combination fire smoke dampers. Duct smoke detection can also serve to protect the air conditioning system itself from fire and smoke damage.

There are several important documents that provide guidance concerning the performance, application and installation of duct detectors:

- 1) NFPA Standard 90A, *Installation of Air Conditioning and Ventilation Systems*
- 2) NFPA Standard 92A, *Recommended Practice for Smoke Control Systems*
- 3) NFPA Standard 72, *National Fire Alarm Code*
- 4) NFPA Standard 101, *Life Safety Code*
- 5) UL Standard 268A, *Standard for Smoke Detectors for Duct Applications*
- 6) ASHRAE Handbook and Product Directory, "Fire and Smoke Control"
- 7) System Sensor, *Guide for Proper Use of Smoke Detectors in Duct Applications.*

Duct detectors are:

- NOT** a substitute for an open area smoke detector
- NOT** a substitute for early warning detection
- NOT** a replacement for a building's regular fire detection system

Specifications

Type:	Photoelectric
Air Duct Velocity:	0 to 3000 fpm (0 to 15.2 m/s)
Operating Temperature Range:	32°F to 120°F (0° to 49°C)
Operating Humidity Range:	10% to 93% RH
Operation Voltage:	120 VAC
Dimensions:	4 in. (101mm)

Features

- Designed for mounting on standard electrical box
- Low-profile smoke detector design
- Built-in test switch

Listings

UL 268A

Refer to Greenheck Installation Supplement: Part # 465915- No flow smoke detector IOM

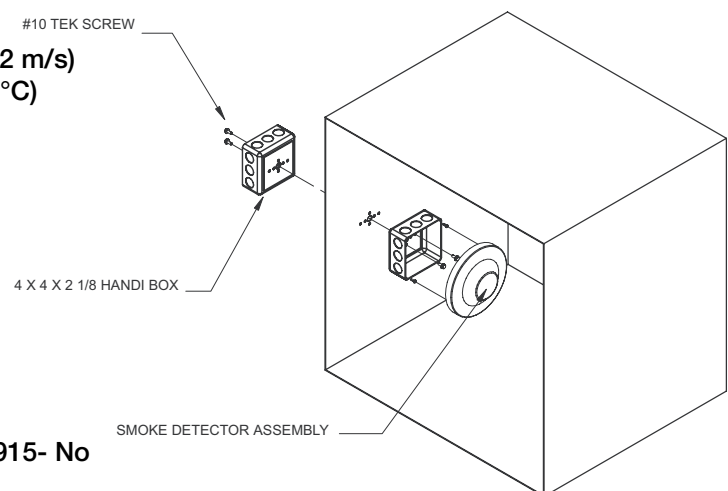

Sleeve Length

Height less than 11 in. (279mm): 21 in. (533mm) sleeve with
12 in. (305mm) "A" dimension

Height equal to or greater than 11 in. (279mm): 16 in. (406mm) sleeve with
9.5 in. (241mm) "A" dimension

Ordering Options

Factory Mounted

Smoke detector will be wired to a 4 x 4 handi-box. The closure device (if RRL or TOR) will also be wired to the handi-box. Dampers provided with the smoke detector option will include single point wiring as standard (includes RRL, OCI, TOR, and detectors).

Shipped Loose

Shipped loose smoke detector will only include the detector itself (no mounting hardware or bracket seals). Note: Dampers ordered with shipped loose smoke detectors will have the standard sleeve length, not a longer sleeve to accommodate the smoke detector installation. If smoke detectors are intended to be field mounted on the damper sleeve, the damper sleeve length and 'A' dimension will need to be manually changed to the requirements indicated under 'Sleeve Length'.

Wiring Diagrams

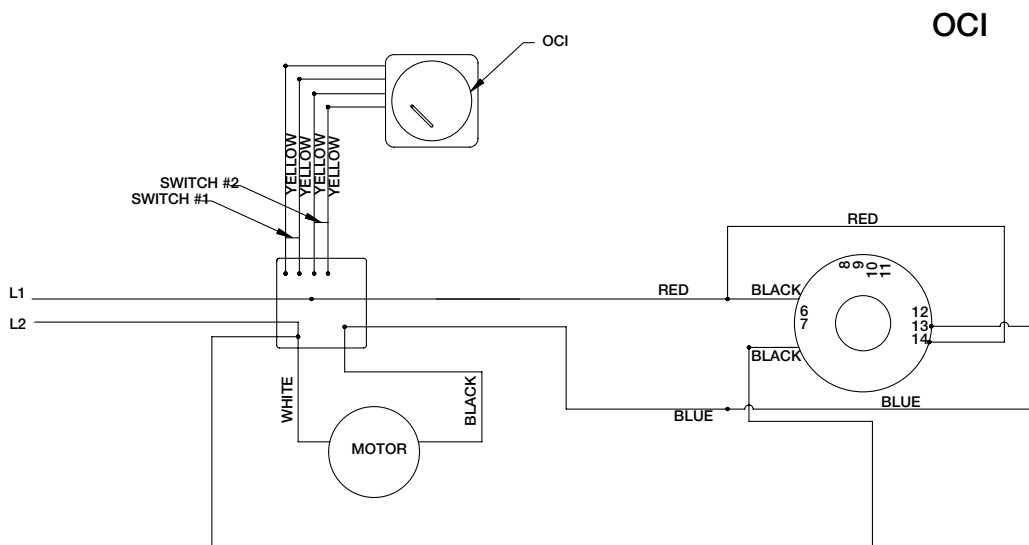
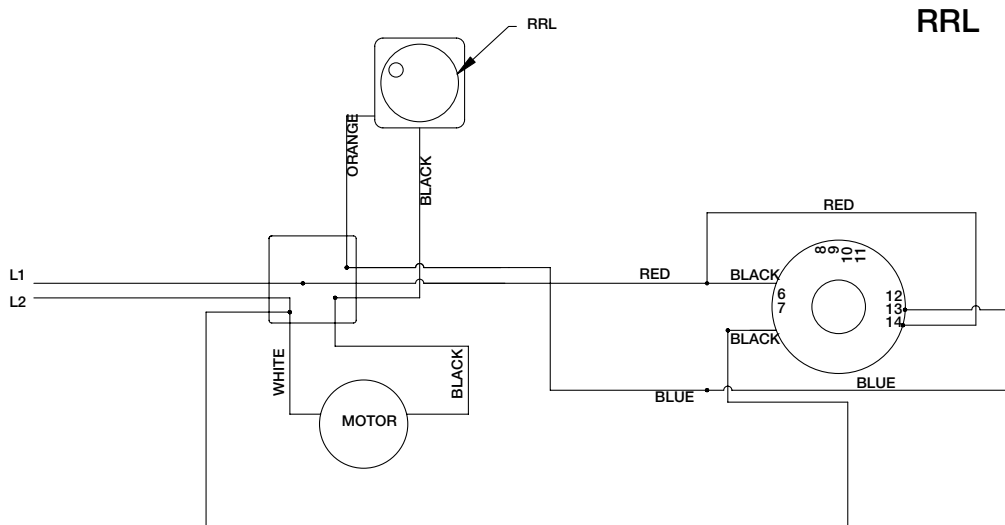

Wiring Diagrams

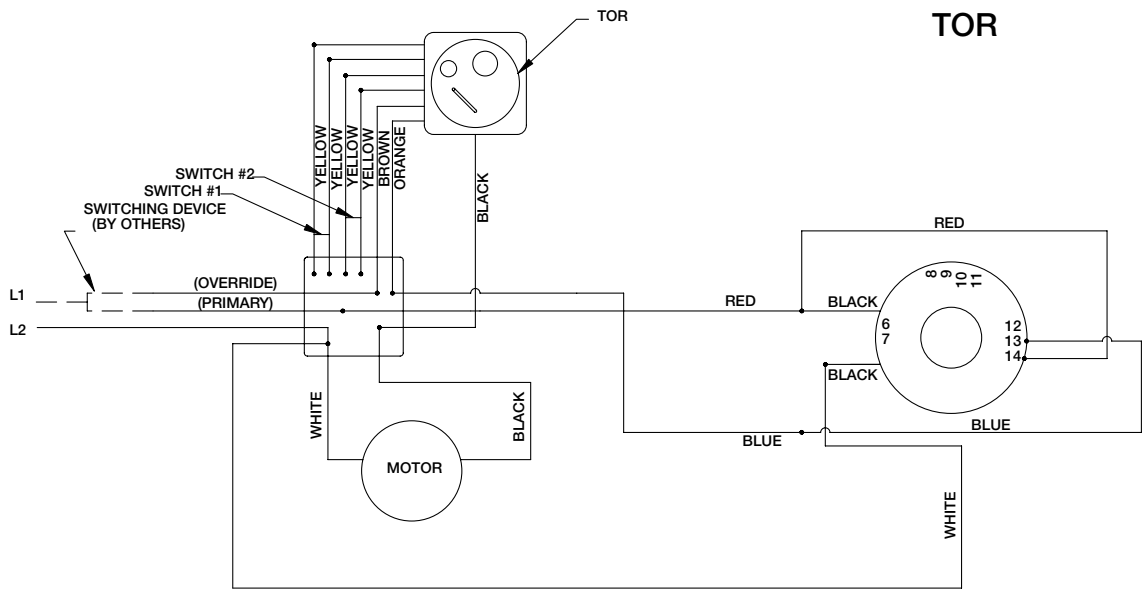
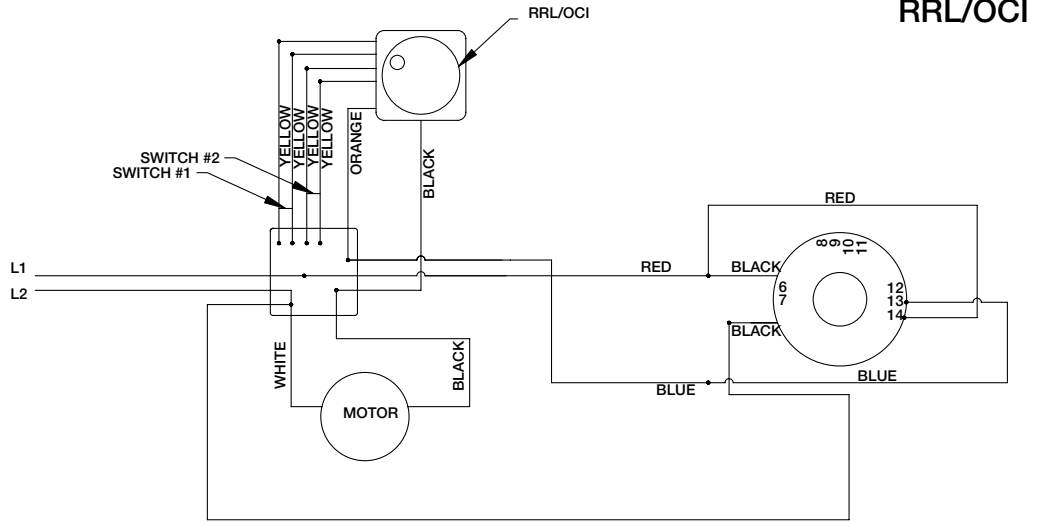

Wiring Diagrams with EP Switch

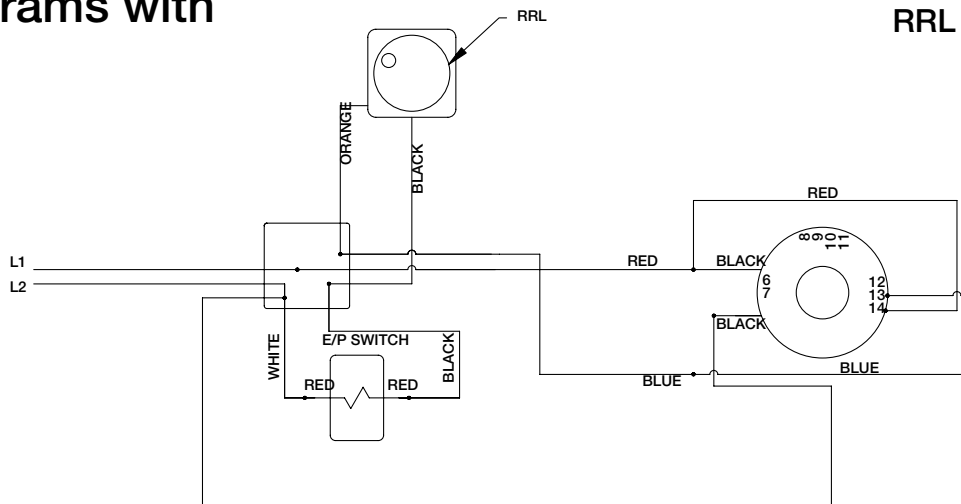

Wiring Diagrams with EP Switch continued..

