

NMX120-3

On/Off, Floating Point, Non-Spring Return, 100 to 240 VAC

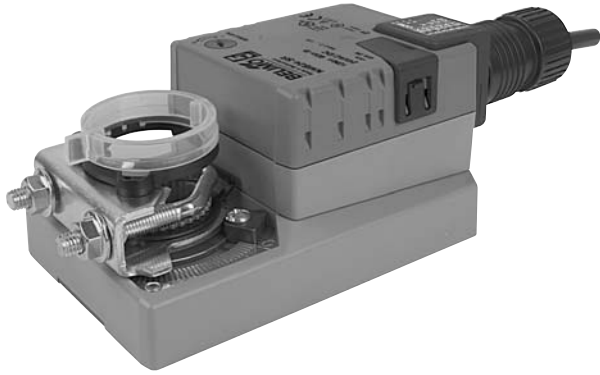

Technical Data		NMX120-3
Power supply	nominal	100 to 240 VAC, 50/60 Hz
	tolerance	85 to 265 VAC, 50/60 Hz
Power consumption		3.5 W (0.6 W)
Transformer sizing		5.5 VA (Class 2 power source)
Electrical connection		18 GA appliance rated cable 1/2" conduit connector protected NEMA 2 (IP54) 3 ft [1m] 10 ft [3m] 16 ft [5m]
Overload protection		electronic throughout 0 to 95° rotation
Control		on/off, floating point
Input impedance		600 Ω
Angle of rotation		max. 95°, adjustable with mechanical stop
Torque		90 in-lb [10 Nm]
Direction of rotation		reversible with switch
Position indication		reflective visual indicator (snap-on)
Manual override		external push button
Running time		150 seconds 95 seconds 60 seconds 45 seconds constant independent of load
Humidity		5 to 95% RH non condensing (EN 60730-1)
Ambient temperature		-22°F to 122°F [-30°C to 50°C]
Storage temperature		-40°F to 176°F [-40°C to 80°C]
Housing		NEMA 2, IP54, UL enclosure type 2
Housing material		UL94-5VA
Agency listings†		cULus acc. to UL 60730-1A/-2-14, CAN/CSA E60730-1:02, CE acc. to 2004/108/EEC and 2006/95/EC
Noise level		<45dB(A)
Servicing		maintenance free
Quality standard		ISO 9001
Weight		1.7 lbs [0.75 kg]

†Rated Impulse Voltage 4kV, Type of action 1, Control Pollution Degree 3.

Torque min. 90 in-lb for control of damper surfaces up to 22 sq ft.

Application

For on/off and floating point control of dampers in HVAC systems. Actuator sizing should be done in accordance with the damper manufacturer's specifications.

The actuator is mounted directly to a damper shaft up to 1.05" in diameter by means of its universal clamp, 1/2" self-centered default. A crank arm and several mounting brackets are available for applications where the actuator cannot be direct coupled to the damper shaft.

Operation

The actuator is not provided with and does not require any limit switches, but is electronically protected against overload. The anti-rotation strap supplied with the actuator will prevent lateral movement.

The NMX series provides 95° of rotation and a visual indicator indicates position of the actuator. When reaching the damper or actuator end position, the actuator automatically stops. The gears can be manually disengaged with a button on the actuator cover.

The NMX120-3... actuators use a sensorless brushless DC motor, which is controlled by an Application Specific Integrated Circuit (ASIC). The ASIC monitors and controls the actuator's rotation and provides a digital rotation sensing (DRS) function to prevent damage to the actuator in a stall condition. Power consumption is reduced in holding mode.

Add-on auxiliary switches or feedback potentiometers are easily fastened directly onto the actuator body for signaling and switching functions.

Dimensions (Inches [mm])

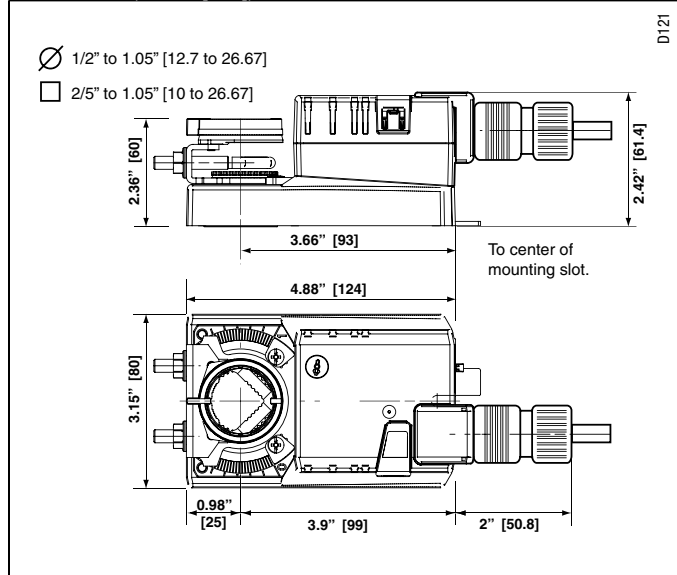

IM40024 - 05/10 - Subject to change. © Belimo Aircontrols (USA), Inc.

Accessories

K-NA	Reversible Clamp
ZG-100	Universal Mounting Bracket
ZG-101	Universal Mounting Bracket
ZG-103	Universal Mounting Bracket
ZG-104	Universal Mounting Bracket
ZG-NMA	Crank arm Adaptor Kit
AV8-25	Universal Shaft Extension
ZG-NMSA-1	Shaft Adaptor
ZS-100	Weather Shield - Steel
ZS-150	Weather Shield - Polycarbonate
Tool-06	8 mm & 10 mm Wrench
S1A, S2A	Auxiliary Switch (es)
P370	Shaft Mount Auxiliary Switch
P...A	Feedback Potentiometers

NOTE: When using NMX120-3 actuators, only use accessories listed on this page.

Typical Specification

Floating point, on/off control damper actuators shall be electronic direct-coupled type, which require no crank arm and linkage and be capable of direct mounting to a shaft up to 1.05" diameter. Actuators shall have brushless DC motor technology and be protected from overload at all angles of rotation. Actuators shall have reversing switch and manual override on the cover. Run time shall be constant and independent of torque. Actuators shall be cULus listed, have a 5-year warranty, and be manufactured under ISO 9001 International Quality Control Standards. Actuators shall be as manufactured by Belimo.

Wiring Diagrams

✂️ INSTALLATION NOTES

1 Provide overload protection and disconnect as required.

2 **CAUTION Equipment Damage!**
Actuators may be connected in parallel.
Power consumption and input impedance must be observed.

📄 APPLICATION NOTES

◆ Meets cULus or UL and CSA Standard requirements without the need of an electrical ground connection.

⚠️ WARNING Live Electrical Components!

During installation, testing, servicing and troubleshooting of this product, it may be necessary to work with live electrical components. Have a qualified licensed electrician or other individual who has been properly trained in handling live electrical components perform these tasks. Failure to follow all electrical safety precautions when exposed to live electrical components could result in death or serious injury.

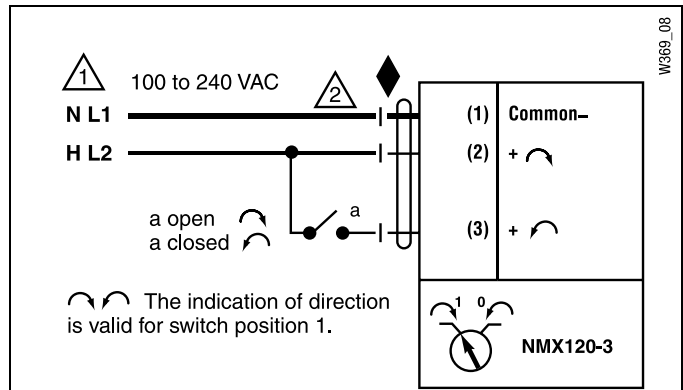

On/Off control

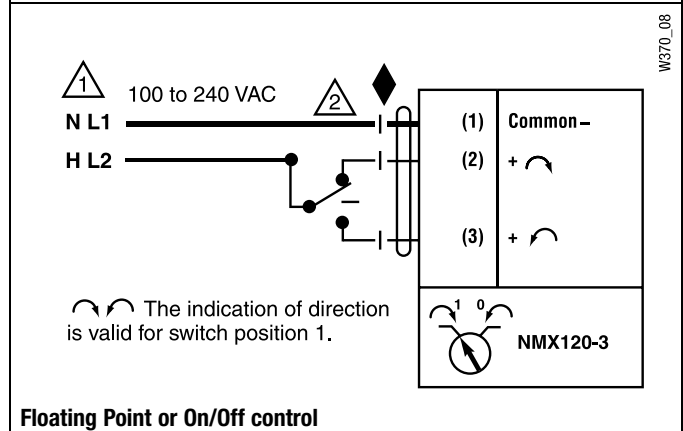

Floating Point or On/Off control

NMX120-SR

Proportional, Non-Spring Return, 100 to 240 VAC, for 2 to 10 VDC or 4 to 20 mA



Technical Data		NMX120-SR
Power supply	nominal	100 to 240 VAC, 50/60 Hz
	tolerance	85 to 265 VAC, 50/60 Hz
Power consumption		3.5 W (1 W)
Transformer sizing		6.5 VA (Class 2 power source)
Electrical connection		18 GA appliance rated cable
		1/2" conduit connector
		protected NEMA 2 (IP54) 3 ft [1m] 10 ft [3m] 16 ft [5m]
Overload protection		electronic throughout 0 to 95° rotation
Operating range Y		2 to 10 VDC, 4 to 20 mA
Input impedance		100 kΩ (0.1 mA), 500 Ω
Feedback output U		2 to 10 VDC (max 0.5 mA)
Angle of rotation		max. 95°, adjust. with mechanical stop
Torque		90 in-lb [10 Nm]
Direction of rotation		reversible with switch
		actuator will move:
		=CCW with decreasing control signal (10 to 2V) =CW with decreasing control signal (10 to 2V)
Position indication		reflective visual indicator (snap-on)
Manual override		external push button
Running time		150 seconds 95 seconds 60 seconds 45 seconds
		constant independent of load
Humidity		5 to 95% RH non condensing (EN 60730-1)
Ambient temperature		-22°F to 122°F [-30°C to 50°C]
Storage temperature		-40°F to 176°F [-40°C to 80°C]
Housing		NEMA 2, IP54, UL enclosure type 2
Housing material		UL94-5VA
Agency listings†		cULus acc. to UL 60730-1A/-2-14, CAN/CSA E60730-1:02, CE acc. to 2004/108/EEC and 2006/95/EC
Noise level		<45dB(A)
Servicing		maintenance free
Quality standard		ISO 9001
Weight		1.7 lbs [0.75 kg]

†Rated Impulse Voltage 4kV, Type of action 1, Control Pollution Degree 3.

Torque min. 90 in-lb for control of damper surfaces up to 22 sq ft.

Application

For proportional modulation of dampers in HVAC systems. Actuator sizing should be done in accordance with the damper manufacturer's specifications.

The actuator is mounted directly to a damper shaft up to 1.05" in diameter by means of its universal clamp, 1/2" self centered default. A crank arm and several mounting brackets are available for applications where the actuator cannot be direct coupled to the damper shaft.

The actuator operates in response to a 2 to 10 VDC, or with the addition of a 500 Ω resistor, a 4 to 20 mA control input from an electronic controller or positioner. A 2 to 10 VDC feedback signal is provided for position indication or master-slave applications.

Operation

The actuator is not provided with and does not require any limit switches, but is electronically protected against overload. The anti-rotation strap supplied with the actuator will prevent lateral movement.

The NMX series provides 95° of rotation and a visual indicator indicates position of the actuator. When reaching the damper or actuator end position, the actuator automatically stops. The gears can be manually disengaged with a button on the actuator cover.

The NMX120-SR actuators use a sensorless brushless DC motor, which is controlled by an Application Specific Integrated Circuit (ASIC). The ASIC monitors and controls the actuator's rotation and provides a digital rotation sensing (DRS) function to prevent damage to the actuator in a stall condition. Power consumption is reduced in holding mode.

Add-on auxiliary switches or feedback potentiometers are easily fastened directly onto the actuator body for signaling and switching functions.

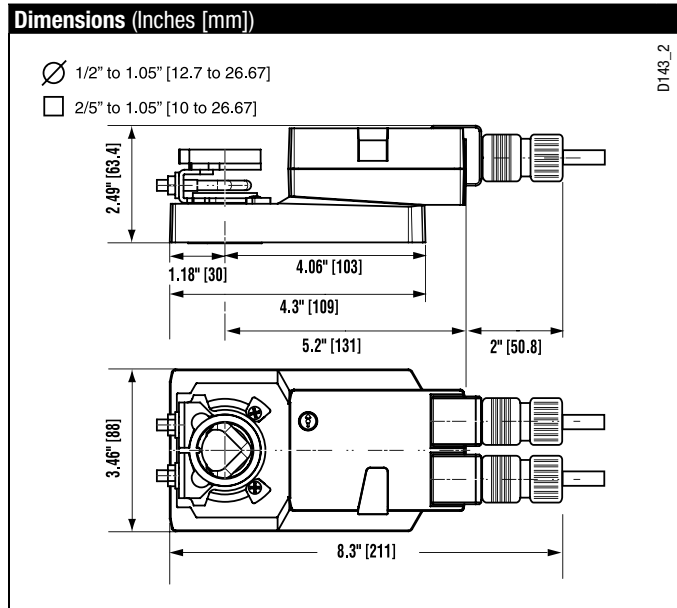

M40024 - 05/10 - Subject to change. © Belimo Aircontrols (USA), Inc.

Accessories

K-NA	Reversible Clamp
ZG-100	Universal Mounting Bracket
ZG-101	Universal Mounting Bracket
ZG-103	Universal Mounting Bracket
ZG-104	Universal Mounting Bracket
ZG-NMA	Crank arm Adaptor Kit
AV8-25	Universal Shaft Extension
ZG-NMSA-1	Shaft Adaptor
ZS-100	Weather Shield - Steel
ZS-150	Weather Shield - Polycarbonate
Tool-06	8 mm & 10 mm Wrench
S1A, S2A	Auxiliary Switch (es)
P370	Shaft Mount Auxiliary Switch
P...A	Feedback Potentiometers
SGA24	Min positioners in NEMA 4 housing
SGF24	Min positioners for flush panel mounting
PTA-250	Pulse Width Modulation Interface
IRM-100	Input Rescaling Module
ADS-100	Analog to Digital Switch
ZG-R01	Resistor for 4 to 20 mA Conversion
NSV24 US	Battery Back-Up Module

NOTE: When using NMX120-SR actuators, only use accessories listed on this page.

Typical Specification

Proportional control damper actuators shall be electronic direct-coupled type, which require no crank arm and linkage and be capable of direct mounting to a shaft up to 1.05" diameter. Actuators must provide proportional damper control in response to a 2 to 10 VDC or, with the addition of a 500 Ω resistor, a 4 to 20 mA control input from an electronic controller or positioner. Actuators shall have brushless DC motor technology and be protected from overload at all angles of rotation. Actuators shall have reversing switch and manual override on the cover. Run time shall be constant and independent of torque. A 2 to 10 VDC feedback signal shall be provided for position indication. Actuators shall be cULus listed, have a 5-year warranty, and be manufactured under ISO 9001 International Quality Control Standards. Actuators shall be as manufactured by Belimo.

Wiring Diagram
INSTALLATION NOTES

- 1 Provide overload protection and disconnect as required.
- 2 **CAUTION Equipment Damage!**
Actuators may be connected in parallel.
Power consumption and input impedance must be observed.
- 5 Only connect common to neg. (-) leg of control circuits.

APPLICATION NOTES

- ◆ Meets cULus or UL and CSA Standard requirements without the need of an electrical ground connection.
- ◆ The ZG-R01 500 Ω resistor converts the 4 to 20 mA control signal to 2 to 10 VDC, up to 2 actuators may be connected in parallel.

WARNING Live Electrical Components!
During installation, testing, servicing and troubleshooting of this product, it may be necessary to work with live electrical components. Have a qualified licensed electrician or other individual who has been properly trained in handling live electrical components perform these tasks. Failure to follow all electrical safety precautions when exposed to live electrical components could result in death or serious injury.

