

Model IMO-310

Multi-Blade Fire Marine Damper

Steel Airfoil Blades

USCG Type Approved for Class A-60 Divisions
ABS Approved (PDA)

Application

Model IMO-310 is a multi-blade fire damper with airfoil style blades. The IMO-310 has been qualified to 2000 fpm (10.2 m/s) and 4 in. wg (1 kPa) for dynamic closure in emergency fire situations. Model IMO-310 may be installed vertically (with blades running horizontal) or horizontally and is rated for airflow in either direction.

Ratings

USCG Approval

Fire Rating: A60 for all sizes

ABS Product Design Assessment

Fire Rating A60 for single section dampers
A30 for multi-section dampers

Performance Rating

Dynamic Closure Rating: Actual limits are size dependent
Recommended Velocity: 2000 fpm (10.2 m/s)-consult factory for higher velocities
Maximum Pressure: 4 in. wg (1kPa)

Model IMO-310 meets the requirement for fire damper established by:

International Maritime Fire Test Procedure Code
USCG Type Approved A-60
Approval Number 164.139/0007/0

United States/European Union
MRA Listed (Ships wheel)

ABS Type Approval Design Assessment (PDA)
Approval Number 06-HS154367-PDA

Construction	Standard	Optional
Frame Material	Galvanized steel	-
Frame Material Thickness	16 ga. (1.5mm)	-
Frame Type	5 in. x 1 in. (127mm x 25mm) hat channel	-
Blade Material	Galvanized steel	-
Blade Material Thickness	14 ga. (2mm) equivalent	-
Blade Type	Double Skin Airfoil	-
Linkage	Plated steel out of airstream, concealed in jamb	-
Axle Bearings	Bronze	304SS
Axle Material	Plated steel	-
Closure Device	Fusible link	-
Closure Temperature	165°F (74°C)	212°F (100°C)
Actuator	External manual quadrant	-
Flanges	Double flange on sleeve	-
Flange Size	1 1/2 in. (38mm)	2 in. (51mm) or 2 1/2 in. (64mm)
Sleeve	20 ga. (1mm) galvanized steel	10 (4mm), 14 (2mm), 16 (1.5mm) ga.

Sizes	Inches (mm) W X H
Minimum size	8 x 6 (203 x 152)
Maximum single section size	32 x 32 (813 x 813)
Maximum multi section size	64 x 32 (1626 x 813)

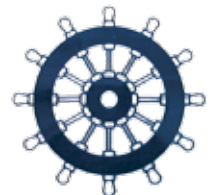

1408/05

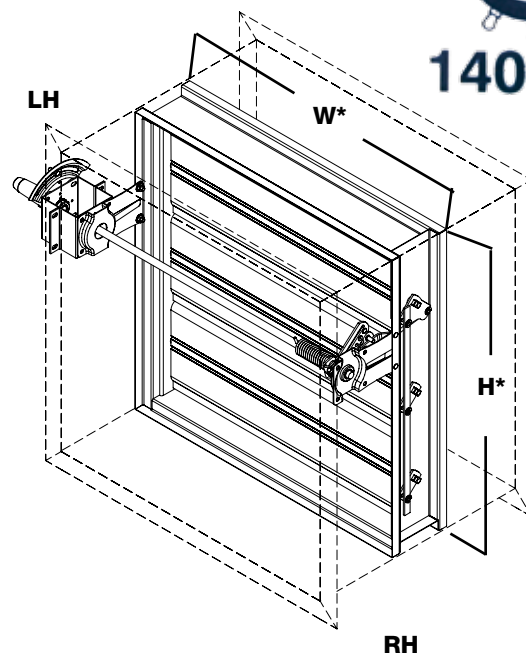

Features

- A low profile head and sill are used on sizes less than 17 in. (432mm) high to maximize free area and performance.

Options

- Greenheck Test Switch (GTS-4)
- OCI (Open Closed Indication) switches
- Security Bars
- Smoke Detector

Installation instructions available at www.greenheck.com

This pressure drop testing was conducted in accordance with AMCA Standard 500-D using the three configurations shown. All data has been corrected to represent standard air at a density of .075 lb/ft³ (1.201 kg/m³).

Actual pressure drop found in any HVAC system is a combination of many factors. This pressure drop information along with an analysis of other system influences should be used to estimate actual pressure losses for a damper installed in a given HVAC system.

AMCA Test Figures

Figure 5.3 Illustrates a fully ducted damper. This configuration has the lowest pressure drop of the three test configurations because entrance and exit losses are minimized by straight duct runs upstream and downstream of the damper.

Figure 5.2 Illustrates a ducted damper exhausting air into an open area. This configuration has a lower pressure drop than Figure 5.5 because entrance losses are minimized by a straight duct run upstream of the damper.

Figure 5.5 Illustrates a plenum mounted damper. This configuration has the highest pressure drop because of extremely high entrance and exit losses due to the sudden changes of area in the system.

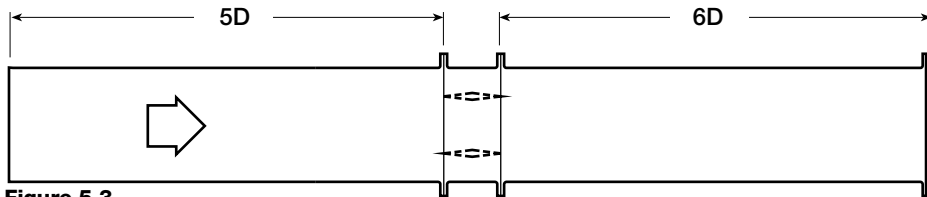

Figure 5.3

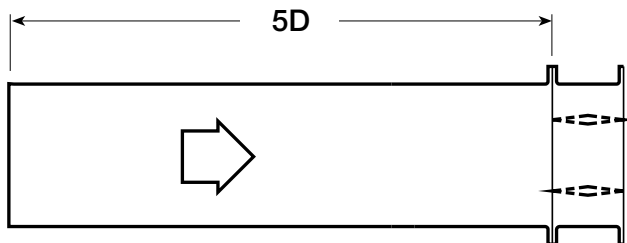

Figure 5.2

$$D = \sqrt{\frac{4(W)(H)}{3.14}}$$

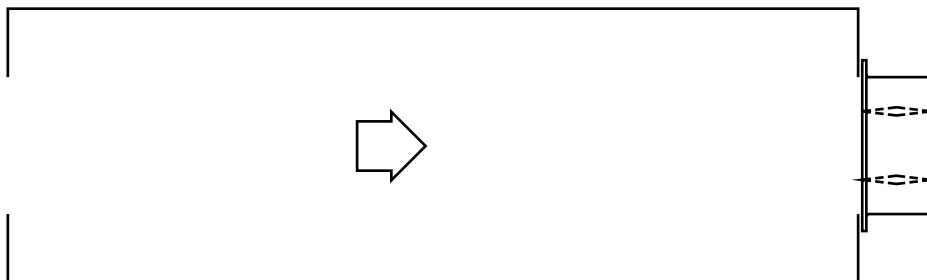
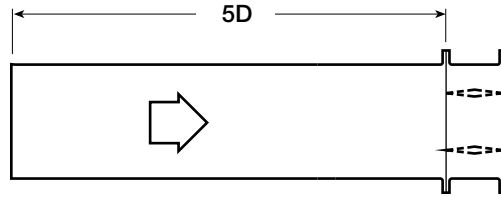
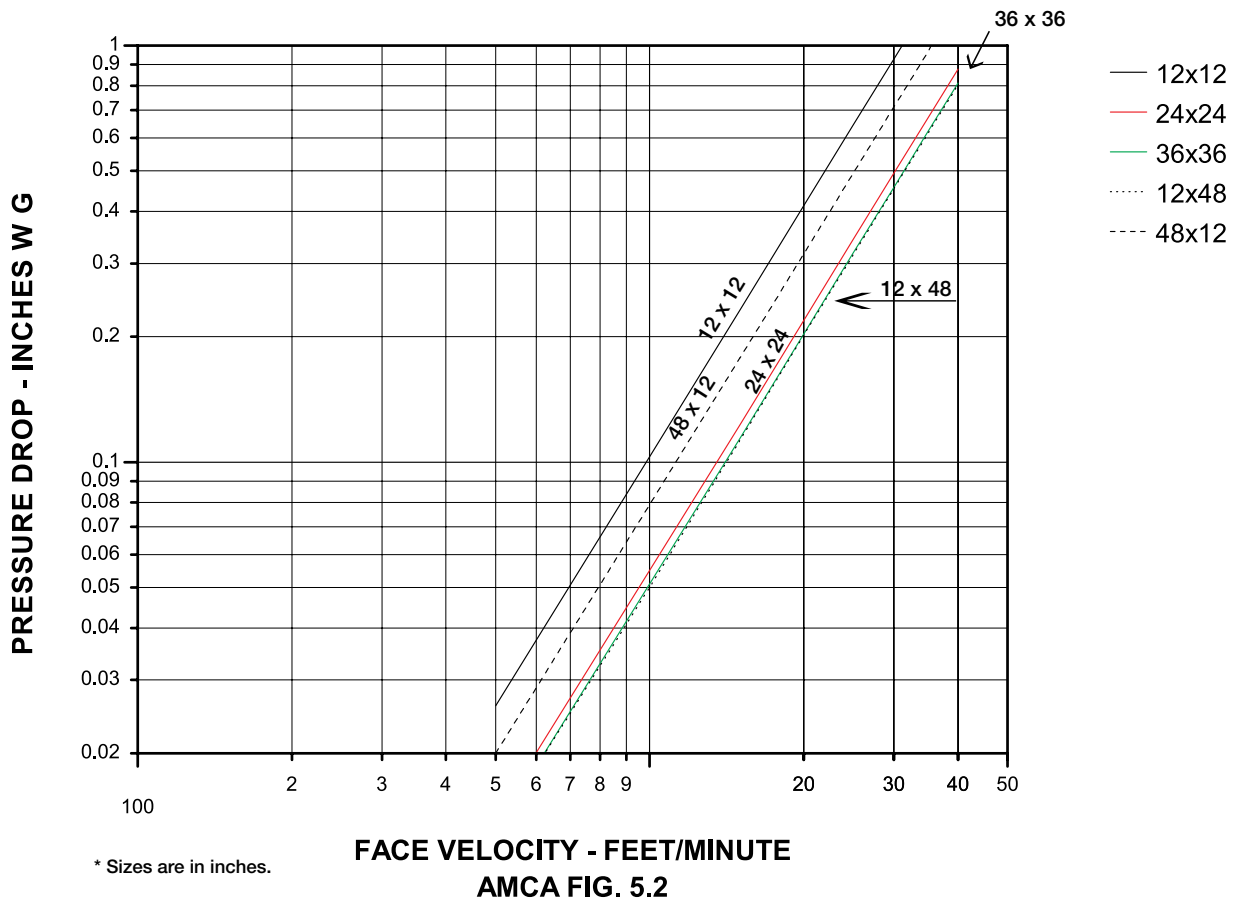

Figure 5.5



VELOCITY VS. PRESSURE DROP*



12 in. x 12 in. (305mm x 305mm)

Velocity (fpm)	Pressure Drop (in. wg)
500	0.02
1000	0.10
1500	0.23
2000	0.41
2500	0.64
3000	0.92
3500	1.26
4000	1.65

24 in. x 24 in. (610mm x 610mm)

Velocity (fpm)	Pressure Drop (in. wg)
500	0.01
1000	0.05
1500	0.12
2000	0.21
2500	0.34
3000	0.49
3500	0.67
4000	0.87

36 in. x 36 in. (914mm x 914mm)

Velocity (fpm)	Pressure Drop (in. wg)
500	0.01
1000	0.05
1500	0.11
2000	0.20
2500	0.31
3000	0.45
3500	0.62
4000	0.81

12 in. X 48 in. (305mm x 1219mm)

Velocity (fpm)	Pressure Drop (in. wg)
500	0.01
1000	0.05
1500	0.11
2000	0.20
2500	0.31
3000	0.45
3500	0.61
4000	0.80

48 in. x 12 in. (1219mm x 305mm)

Velocity (fpm)	Pressure Drop (in. wg)
500	0.02
1000	0.07
1500	0.17
2000	0.31
2500	0.49
3000	0.71
3500	0.96
4000	1.32

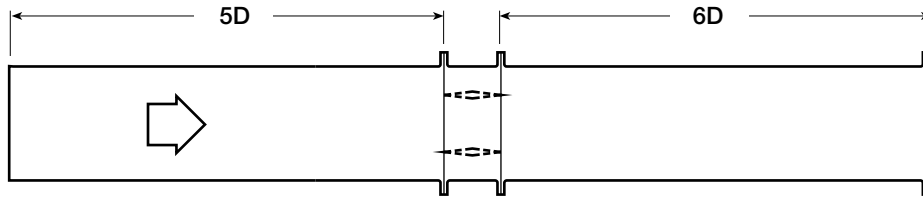

VELOCITY VS. PRESSURE DROP*

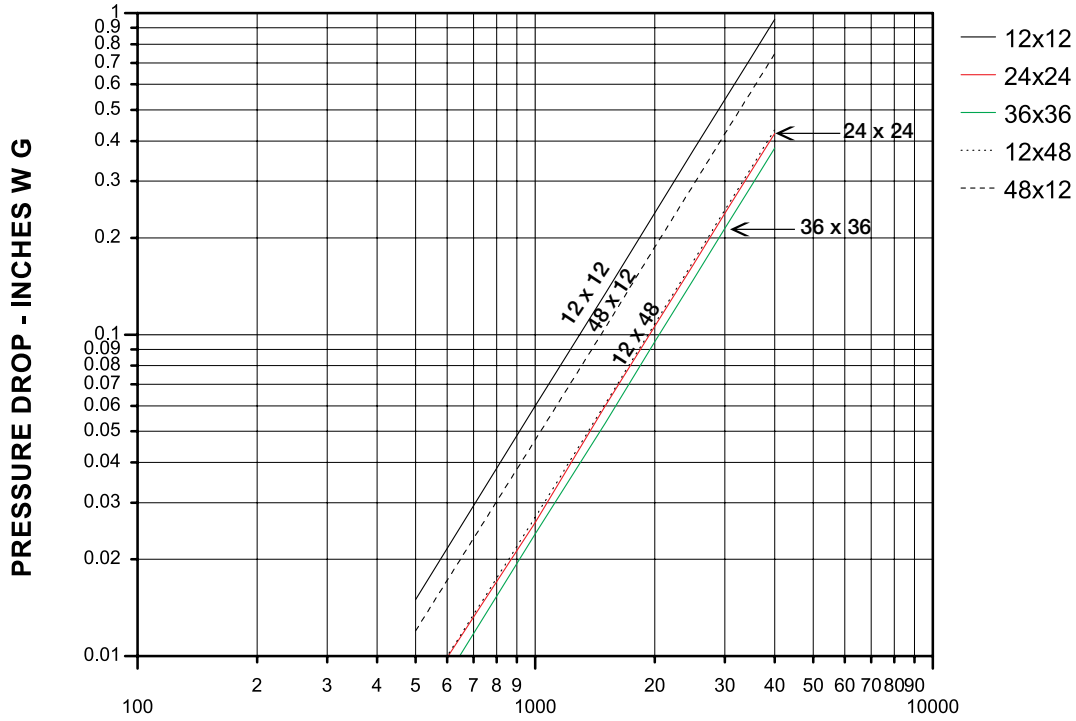

* Sizes are in inches.

FACE VELOCITY - FEET/MINUTE
AMCA FIG. 5.3

12 in. x 12 in. (305mm x 305mm)

Velocity (fpm)	Pressure Drop (in. wg)
500	0.01
1000	0.06
1500	0.13
2000	0.23
2500	0.37
3000	0.53
3500	0.73
4000	0.95

24 in. x 24 in. (610mm x 610mm)

Velocity (fpm)	Pressure Drop (in. wg)
500	0.01
1000	0.02
1500	0.06
2000	0.10
2500	0.16
3000	0.23
3500	0.32
4000	0.42

36 in. x 36 in. (914mm x 914mm)

Velocity (fpm)	Pressure Drop (in. wg)
500	0.01
1000	0.02
1500	0.05
2000	0.09
2500	0.14
3000	0.21
3500	0.29
4000	0.38

12 in. X 48 in. (305mm x 1219mm)

Velocity (fpm)	Pressure Drop (in. wg)
500	0.01
1000	0.02
1500	0.06
2000	0.10
2500	0.16
3000	0.24
3500	0.33
4000	0.43

48 in. x 12 in. (1219mm x 305mm)

Velocity (fpm)	Pressure Drop (in. wg)
500	0.01
1000	0.04
1500	0.10
2000	0.18
2500	0.29
3000	0.42
3500	0.57
4000	0.74

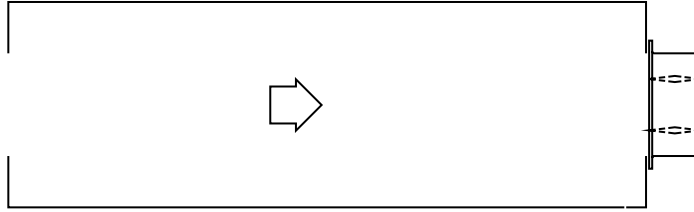

VELOCITY VS. PRESSURE DROP *

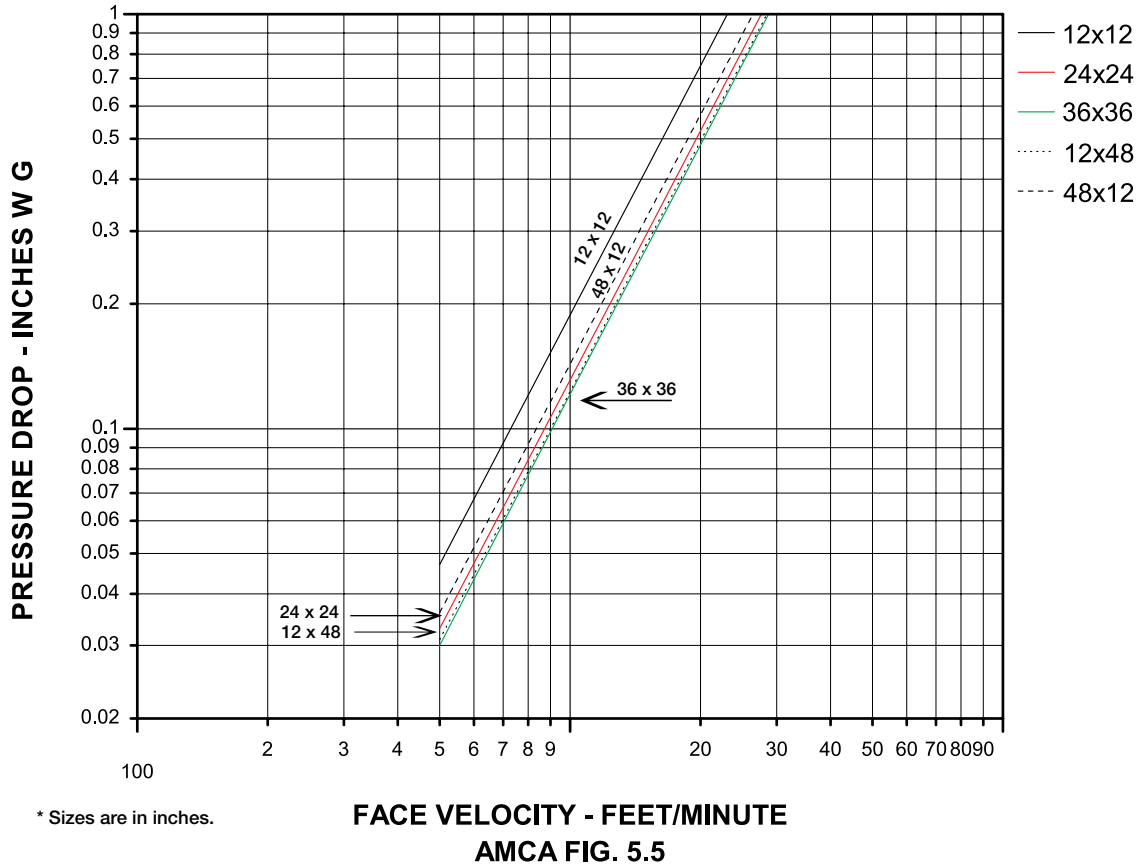

12 in. x 12 in. (305mm x 305mm)

Velocity (fpm)	Pressure Drop (in. wg)
500	0.04
1000	0.18
1500	0.42
2000	0.75
2500	1.17
3000	1.68
3500	2.29
4000	2.09

24 in. x 24 in. (610mm x 610mm)

Velocity (fpm)	Pressure Drop (in. wg)
500	0.03
1000	0.13
1500	0.29
2000	0.52
2500	0.81
3000	1.17
3500	1.60
4000	2.14

36 in. x 36 in. (914mm x 914mm)

Velocity (fpm)	Pressure Drop (in. wg)
500	0.03
1000	0.12
1500	0.27
2000	0.48
2500	0.75
3000	1.08
3500	1.48
4000	1.93

12 in. X 48 in. (305mm x 1219mm)

Velocity (fpm)	Pressure Drop (in. wg)
500	0.03
1000	0.12
1500	0.27
2000	0.49
2500	0.77
3000	1.11
3500	1.51
4000	1.97

48 in. x 12 in. (1219mm x 305mm)

Velocity (fpm)	Pressure Drop (in. wg)
500	0.03
1000	0.14
1500	0.32
2000	0.57
2500	0.89
3000	1.28
3500	1.75
4000	2.29

Damper Sizing Information

Dampers larger than maximum single section size are supplied as a factory assembly of two sections of equal size. The following figures show maximum damper section size and assembly configurations for multi-section dampers.

Single Section

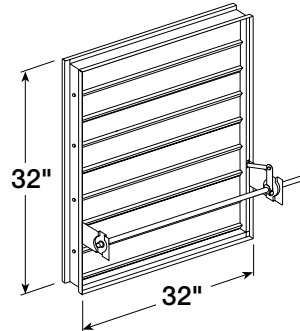

Double Section

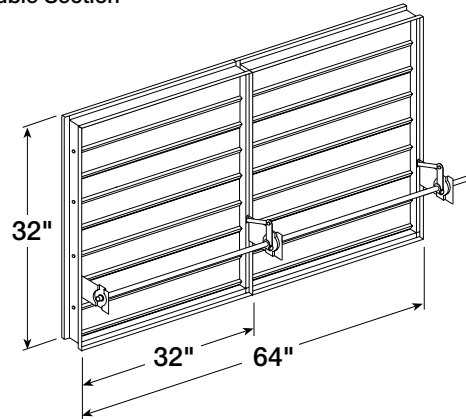

Damper Sleeve Dimensional Data

The drawings below and corresponding table show the position of the IMO-310 damper when mounted in a factory sleeve. The standard mounting locations provide enough space for the mounting of manual quadrant, controls and allow space for installation of retaining angles and duct connections.

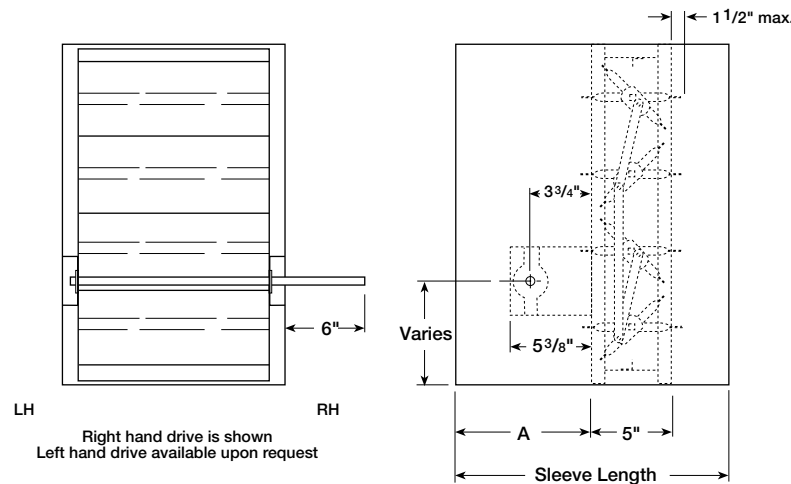

	"A" Dimension	
	Standard	Maximum
All Dampers*	7 3/4 in. (183 mm)	12 in. (305mm)
When H is 10 in. (254mm) or less w/OCI	12 in. (305mm)	12 in. (305mm)

* All dampers w/o OCI

Damper Weights- Weights are approximates. Sizes are in inches (mm).

	Actual Size - in. (mm)	Weight- lb (kg)
IMO-310/ SSIMO-310	8 x 8 (203x203)	11 (5)
	10 x 10 (254x254)	14 (6.4)
	12 x 12 (305x305)	17 (7.7)
	18 x 18 (457x457)	28 (12.7)
	20 x 20 (508x508)	31 (14)
	24 x 24 (610x610)	39 (17.7)
	30 x 30 (762x762)	52 (23.6)
	32 x 32 (813x813)	58 (26.3)
	64 x 32 (1626x813)	96 (43.5)

Specifications

Greenheck's Marine Fire Damper meet the following specifications shall be furnished and installed where shown on plans and/or described in schedules.

Dampers shall be tested and rated in accordance with the latest edition of Coast Guard Approval Type A-60. The heat responsive device shall have a temperature rating of (specifier select one of the following) 165°F (74°C), 212°F (100°C). The damper shall have a dynamic closure pressure rating of 4 in. wg (1 kPa).

Damper shall consist of 16 ga. (1.5mm) galvanized steel channel frame with 14 in. (356mm) minimum depth and 1 1/2 in. (38mm) double flanged on a 20 ga. (1mm) sleeve; double skin airfoil type blades fabricated from two layers of 20 ga. (1mm) galvanized steel; 1/2 in. (13mm) dia. plated steel axles with bronze bearings; and external (out of airstream) blade-to- blade linkage.

Damper actuator shall be manual quadrant. Manufacturers submittal data shall indicate actuator space requirements around the damper.

Damper manufacturer's printed application and performance data including pressure, velocity and temperature limitations shall be submitted for approval showing damper suitable for pressures up to 4 in.wg (1 kPa), velocities up to 2000 fpm (10.2 m/s) and temperatures to 212°F (100°C).

Damper shall be equipped with jamb seals for low leakage performance. Jamb seals shall be flexible stainless steel.

Basis of design is Greenheck Model IMO-310.

