

## Industrial Control Damper Steel Airfoil Blades

### Application and Design

Model HCD-530 is a heavy duty flanged frame style industrial control damper with airfoil blades. It is designed to control airflow and provide shut off in HVAC or industrial process control systems. A variety of optional features makes model HCD-530 extremely versatile, allowing its capabilities to be tailored to the application. Available with parallel or opposed blade action.

### Ratings (See pages 2 and 3 for specific limitations)

**Pressure:** 12 - 45 in. wg (3 - 11.2 kPa) - differential pressure

**Velocity:** 3500 - 6000 fpm (17.8 - 30.5 m/s)

**Temperature:** -60°F to 600°F (-51°C to 315°C). Consult factory for other temperatures.

### Construction

	Standard	Optional
<b>Frame Depth (C)</b>	10 in. (254mm)	-
<b>Frame Material</b>	Galvanized Steel	304SS, 316SS, Painted
<b>Frame Type</b>	Flanged Channel	
<b>Frame Thickness</b>	10 ga. (3.5mm)	-
<b>Flange Width (D)</b>	2 in. (51mm)	2 1/2 in. (64mm)
<b>Blade Action</b>	Parallel	Opposed
<b>Blade Material</b>	Galvanized Steel	304SS, 316SS, Painted
<b>Blade Seals</b>	None	EPDM, Silicone, Fiberglass tadpole
<b>Blade Thickness</b>	12 ga. (2.7mm)	10 ga. (3.5mm)
<b>Blade Type</b>	Double Skin Airfoil	
<b>Linkage</b>	Plated Steel	304SS, 316SS
<b>Jamb Seals</b>	None	304SS, 316SS
<b>Axle Diameter</b>	1 in. (25mm)	-
<b>Axle Bearing</b>	External Bronze Sleeve	External Relubricable Ball, Outboard Bronze Sleeve, Outboard Relubricable Ball
<b>Axle Material</b>	Plated Steel	304SS, 316SS
<b>Axle Seals</b>	None	O-ring, Double Gland Stuffing Box
<b>Paint Finishes</b>	None	Epoxy, Hi Pro Polyester, Hi Temperature Aluminum, Hi Temperature Silver, Industrial Epoxy, Permator™

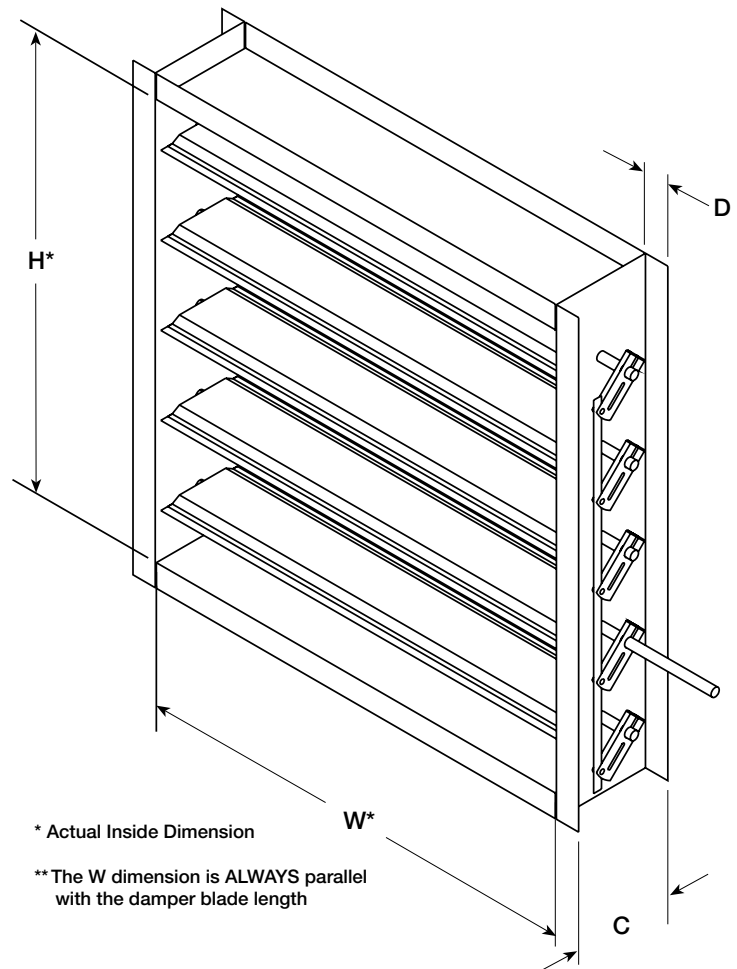

### Features:

- Linkage is external heavy duty type with galvanized steel clevis arms and tie bars and plated steel pivot pins.
- Double skin airfoil shape blades of galvanized steel with full length structural reinforcement.
- Blades run vertically\*\*, consult factory.
- Wide mounting flanges can be ordered with bolt holes, customized to match your requirements.

### Options:

- Position Indicator
  - Open Close Indicator (OCI)
  - External Switch

### Size Limitations

W x H	Minimum Size	Maximum Size	
		Single Section	Multi - Section
Inches	6 x 6	72 x 96	120 x 96
mm	152 x 152	1829 x 2438	3048 x 2438

## Pressure Limitations

The chart at the right shows conservative pressure limitations based on a maximum blade deflection of  $w/360$ .

## Temperature Limitations

- Blade seals: Silicone Rubber -40° to +400°F (-40° to +204°C)
- EPDM -20° to +250°F (-29° to +121°C)
- Jamb seals: Flexible stainless steel -40° to +400°F (-40° to +204°C)

For higher temperatures, consult Greenheck

## Velocity Limitations

The chart at far right shows conservative velocity limitations based on damper size.

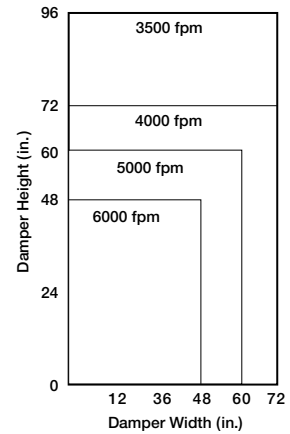
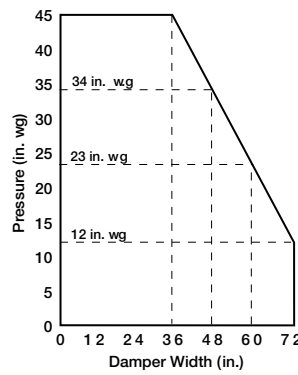

## Pressure Drop Data

This pressure drop data was conducted in accordance with AMCA Standard 500-D using the three configurations shown. All data has been corrected to represent standard air at a density of .075 lb/ft<sup>3</sup> (1.2 kg/m<sup>3</sup>).

Actual pressure drop found in any HVAC system is a combination of many factors. This pressure drop information along with an analysis of other system influences should be used to estimate actual pressure losses for a damper installed in a given HVAC system.

## AMCA Test Figures

**Figure 5.3** Illustrates a fully ducted damper. This configuration has the lowest pressure drop of the three test configurations because entrance and exit losses are minimized by straight duct runs upstream and downstream of the damper.

**Figure 5.2** Illustrates a ducted damper exhausting air into an open area. This configuration has a lower pressure drop than Figure 5.5 because the entrance losses are minimized by a straight duct run upstream of the damper.

**Figure 5.5** Illustrates a plenum mounted damper. This configuration has the highest pressure drop because of the high entrance and exit losses due to the sudden changes of area in the system.

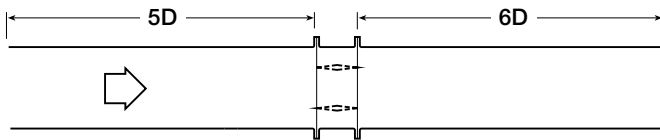

Fig. 5.3

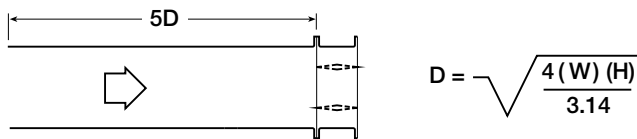

Fig. 5.2

$$D = \sqrt{\frac{4(W)(H)}{3.14}}$$

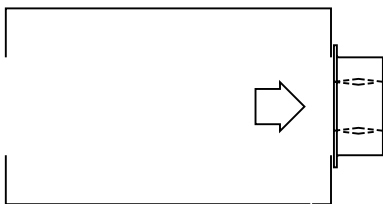
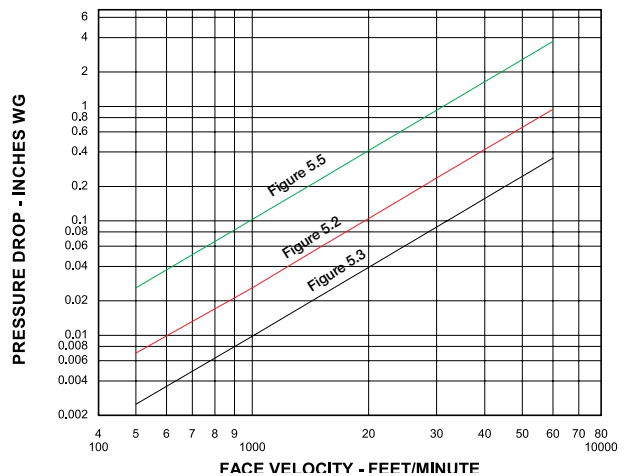

Fig. 5.5

## Pressure Drop 36 in. x 36 in. (914mm x 914mm) Damper



**Leakage**  
**36 in. x 36 in. (914mm x 914mm) Damper**  
 (based on 5 in. lb/ft<sup>2</sup> of torque)

## Leakage Data

Damper leakage (with blades fully closed) varies based on the type of low leakage seals applied. Model HCD-430 is available with no jamb seals (standard) or with stainless steel jamb seals and EPDM or silicone rubber blade seals. Leakage testing was conducted in accordance with AMCA Standard 500-D and is expressed as CFM per sq.ft. of damper face area. All data has been corrected to represent standard air at a density of .075 lb/ft<sup>3</sup> (1.2 kg/m<sup>3</sup>).

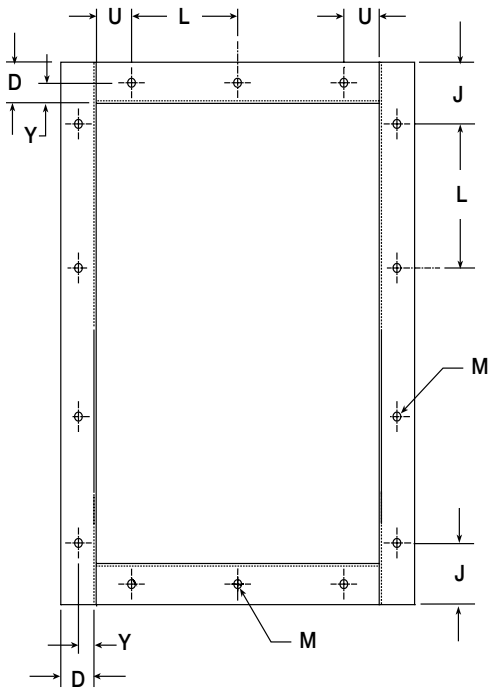
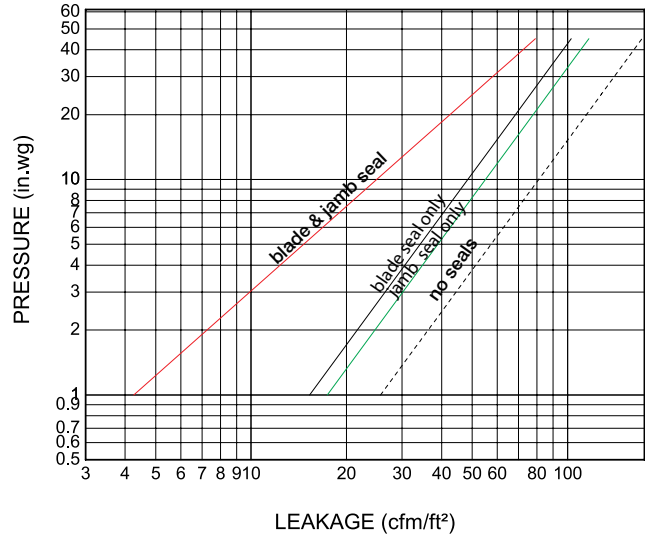

Bolt holes are available as an option. Greenheck's standard pattern is 7/16 in. (11mm) diameter holes (M dimension) spaced 6 in. (152mm) on center (L dimension). Also, available is custom bolt hole pattern within the limitations of the chart below.

### Bolt Hole Limitations

Dim.	Standard	(Min./Max.)	Description
J		(D/2 min.)	First/Last Space in Jamb
F		(1 min.)	No. of Holes in Jamb
L	6 in. (152mm)	2 in. /12 in. (51mm/305mm)	Hole Spacing
M	7/16 in. (11mm)	1/4 in. / 11/16 in. (6mm/17mm)	Mounting Hole Diameter
U		3/4 in. min. (19mm)	First/Last Space in Head/Sill
V		1 min. (25mm)	No. of Holes in Head/Sill
Y	D/2 in. (D/51mm)	3/4 in./D-3/4 in. (19mm/D -19mm)	Centerline of bolt hole from inside edge of frame

## Bearing and Shaft Options

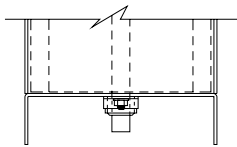

O-Ring Shaft Seal with External Mounted Bronze Sleeve Bearing (Standard)

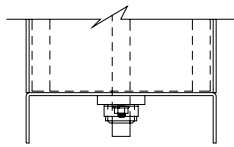

O-Ring Shaft Seal with External Mounted Ball Bearing (Optional)

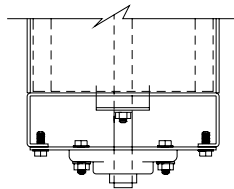

O-Ring Shaft Seal with Outboard Mounted Bearing (Optional)

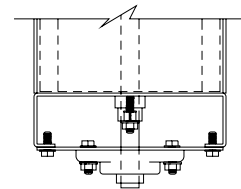

Double Gland Stuffing Box with Outboard Mounted Bearing (Optional)

## Specifications

Industrial grade control dampers meeting the following specifications shall be furnished and installed where shown on plans and/or as described in schedules.

Dampers shall consist of: a 10 ga. (3.5mm) galvanized steel channel frame with 10 in. (254mm) minimum depth and 2.5 in. (64mm) flanges; double skin airfoil type blades fabricated from two layers of 12 ga. (2.7mm) galvanized steel; 1 in. (25mm) dia. plated steel axles turning in externally mounted bronze sleeve bearings; and external (out of the airstream) blade-to-blade linkage. To prevent air leakage through the frame, each blade axle shall be equipped with an optional O-Ring seal where it penetrates the damper frame.

Damper manufacturer's printed application and performance data including pressure, velocity and temperature limitations shall be submitted for approval showing damper suitable for pressures to 45 in. wg (11.2 kPa), velocities to 6000 fpm

(30.5 m/s) and temperatures to 1500°F (816°C). Testing and ratings to be in accordance with AMCA Standard 500-D.

Specifier may add the following:

Dampers shall be equipped with blade and jamb seals for low leakage performance. Blade seals shall be: *select one of the following* EPDM synthetic rubber for 250°F (121°C) maximum temperature, or Silicone Rubber for 400°F (204°C) maximum temperature. Jamb seals shall be flexible stainless steel. Testing and ratings shall be per AMCA Standard 500-D.

Basis of design is Greenheck model HCD 530.

