

Industrial Backdraft Damper

Fan Class III

Application and Design

Model HB-330 is a heavy duty double flanged channel frame style backdraft damper with double thickness fabricated airfoil blades. It is designed to prevent backflow and to provide shut off in HVAC or industrial process systems. External spherical rod end linkage, blade counterbalance, and external mount relubricable ball bearings are standard for high velocity applications.

Ratings (See page 2 for specific limitations)

Pressure: 8.5 - 20 in. wg (2.1 kPa - 5 kPa) - differential pressure

Velocity: 5150 - 6400 fpm (26.2 - 32.5 m/s)

Temperature: Minimum: -40°F (-40°C)

Maximum: 250°F (121°C)

Consult factory for temp. above 250°F (121°C)

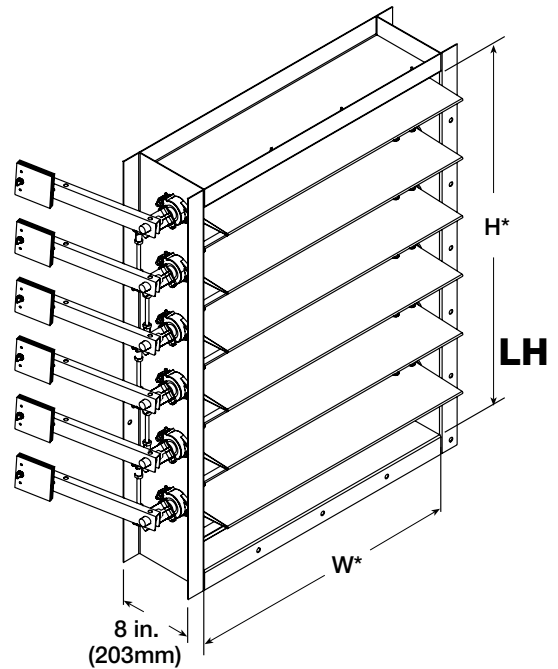
RH

*Actual Inside Dimension. The W dimension is ALWAYS parallel with the damper blade length. RH counterbalance is standard. Counterbalance weights extend beyond inlet flange in the open position.

	Standard	Optional
Frame Material	Galvanized Steel	304SS or 316SS
Frame Type	Flanged Channel	
Frame Depth	8 in. (203mm)	8 in. - 12 in. (203mm - 305mm)
Frame Gauge	12 ga. (2.7mm)	10 ga. (3.5mm)
Blade Material	Galvanized Steel	304SS or 316SS
Blade Type	Airfoil	
Blade Gauge	16 ga. (1.5mm)	-
Blade Seals	Silicone	EPDM, None
Flange Width	2 in. (51mm)	1 1/2 in. - 4 in. (38mm - 305mm)
Axle Bearing	Relubricable Ball	
Axle Diameter	3/4 in. (19mm)	-
Axle Material	Plated Steel	304SS or 316SS
Linkage	External heavy duty type with galvanized steel clevis arms and plated steel tie bars & pivot pins with nylon pivot bearings	304SS or 316SS
Flow Direction	Horizontal	Vertical Up, Vertical Down, Angular Up, Angular Down,
Paint Finishes	Mill Finish	Epoxy, Hi Pro Polyester, Industrial Epoxy

Counterbalance Weight Dimensions

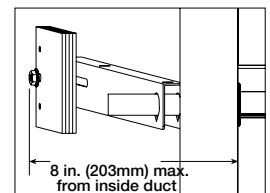
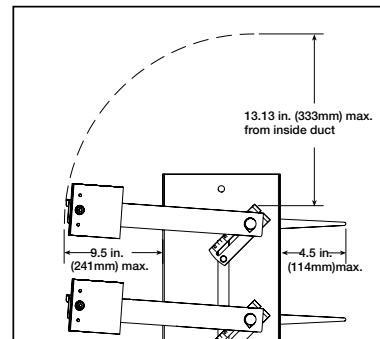
Front View
Side View

Size Limitations

W x H	Minimum Size	Maximum Size	
		Single Section	Multiple Section
Inches	6 x 6	60 x 96	120 x 96
mm	152 x 152	1524 x 2438	3048 x 2438

Options:

- Mounting holes in both flanges

Advise flow direction & counterbalance weight location when ordering

PERFORMANCE DATA

HB-330

Pressure Limitations

The chart at the right shows conservative pressure limitations based on a maximum blade deflection of $w/360$.

Temperature Limitations

-40°F to +250°F (-40°C to 121°C)

For higher temperatures consult Greenheck

Velocity Limitations

The chart at far right shows conservative velocity limitations based on damper size.

Pressure Limitations

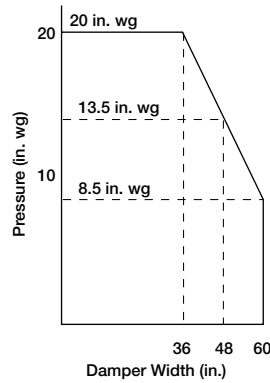

Velocity Limitations

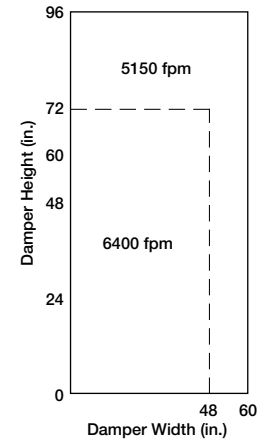

Pressure Drop Data

This pressure drop data was conducted in accordance with AMCA Standard 500-D using the three configurations shown. All data has been corrected to represent standard air at a density of 0.075 lbm/ft³ (1.2 kg/ m³).

Actual pressure drop found in any HVAC system is a combination of many factors. This pressure drop information along with an analysis of other system influences should be used to estimate actual pressure losses for a damper installed in a given HVAC system.

AMCA Test Figures

Figure 5.3 illustrates a fully ducted damper. This configuration has the lowest pressure drop of the three test configurations because entrance and exit losses are minimized by straight duct runs upstream and downstream of the damper.

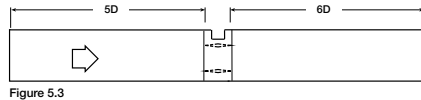

Figure 5.3

Figure 5.2 illustrates a ducted damper exhausting air into an open area. This configuration has a lower pressure drop than Figure 5.5 because the entrance losses are minimized by a straight duct run upstream of the damper.

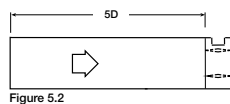

Figure 5.2

$$D = \sqrt{\frac{4(W)(H)}{3.14}}$$

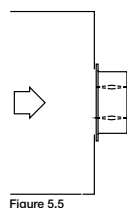

Figure 5.5

AMCA Test Figures

Figure 5.5 illustrates a plenum mounted damper. This configuration has the highest pressure drop because of the high entrance and exit losses due to the sudden changes of area in the system.

Leakage Data

Leakage testing was conducted in accordance with AMCA Standard 500-D and is expressed as cfm/ft² of damper face area. All data has been corrected to represent standard air at a density of 0.075 lb/ft³ (1.2 kg/ m³).

Pressure Drop
36 in. x 36 in. (914mm) Damper

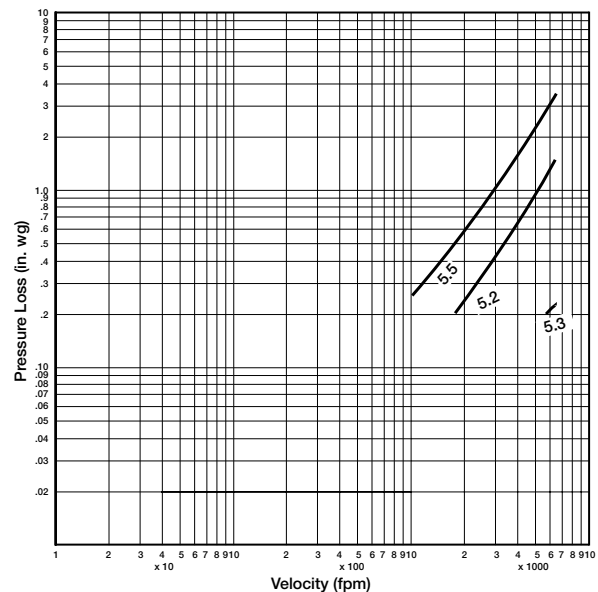

Leakage
36 in. x 36 in. (914mm) Damper

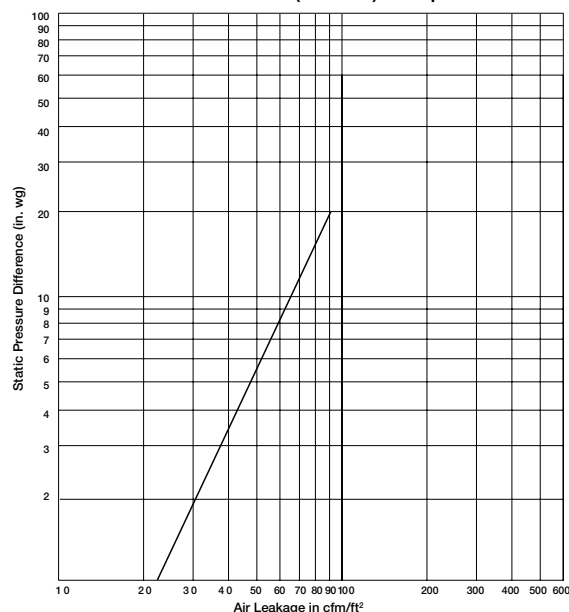

MOUNTING HOLES

HB-330

Mounting Holes Option		
	Standard	Optional
Mounting Holes in Flanges	None	Greenheck standard pattern (7/16 in. diameter holes, spaced 6 in. on center) or Customer Specified within limits shown in table below.

Multiple Section Assembly

Damper sizes larger than 60 in. x 96 in. (1524mm x 2438mm) and up to 120 in. x 96 in. (3048mm x 2438mm) will be supplied in one frame with two sets of blades separated by a mullion as shown below. Counterbalance weights supplied on right hand and left hand side. For sizes larger than 120 in. x 96 in. (3048mm x 2438mm) consult factory.

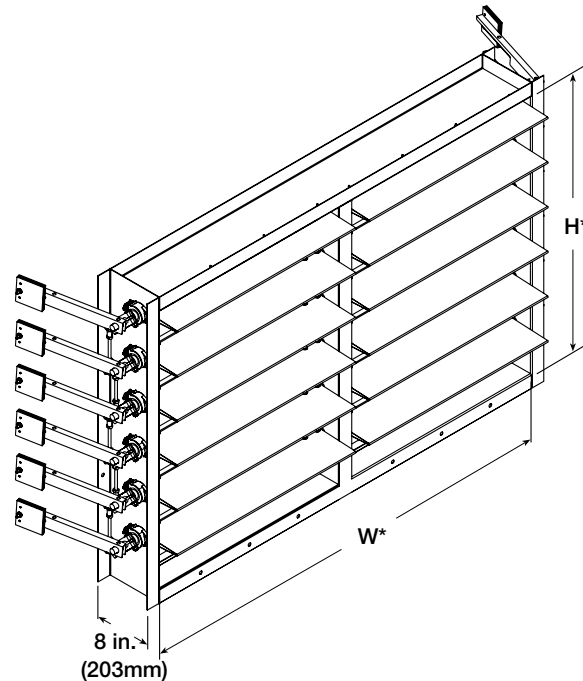
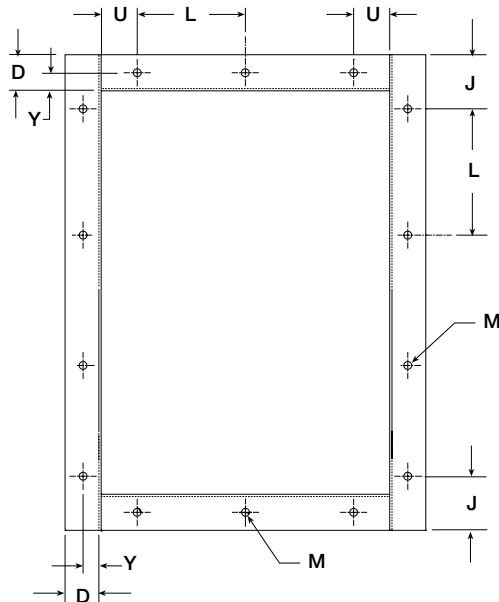

Dimension	Standard	Minimum/Maximum	Description
J		D/2 minimum	First/Last Space in Jamb
F		1 minimum	No. of Holes in Jamb
L	6 in. (152mm)	2 in. - 12 in. (51mm - 305mm)	Hole Spacing
M	7/16 in. (11mm)	1/4 in. - 11/16 in. (6mm - 17mm)	Mounting Hole Diameter
U		3/4 in. (19mm) minimum	First/Last Space in Head/Sill
V		1 minimum	No. of Holes in Head/Sill
Y	D/2 in.	3/4 in./D-3/4 in. (19mm/D-19mm)	Centerline of bolt hole from inside edge of frame

Specifications

Industrial grade backdraft dampers meeting the following specifications shall be furnished and installed where shown on plans and/or as described in schedules.

Dampers shall consist of: a 12 ga. (2.7mm) galvanized steel channel frame with 8 in. (203mm) minimum depth and 2 in. (51mm) flanges; airfoil shaped, 16 ga. (1.5mm) galvanized steel double skin construction blades; silicone rubber blade seals; 3/4 in. (19mm) dia. plated steel axles turning in externally mounted relubricable sealed ball bearings;

and external (out of the airstream) precision 3/8 in. (9.5mm) spherical rod end linkage with counterbalance weights.

Damper manufacturer's printed application and performance data including pressure, velocity and temperature limitations shall be submitted for approval showing damper suitable for pressures to 20 in. wg (5 kPa), velocities to 6400 fpm (32.5 m/s) and temperatures to 250°F (121°C). Testing and ratings to be in accordance with AMCA Standard 500-D.

Basis of design is Greenheck model HB-330.

