

Industrial Backdraft Damper

Application and Design

Model HB-120 is a heavy duty double flanged channel frame style backdraft damper with single thickness blades. It is designed to prevent backflow and to provide shut off in HVAC or industrial process systems. External heavy duty linkage, blade counterbalance, and ball bearings are standard.

Ratings (See page 2 for specific limitations)

Pressure: 5.0 - 8.5 in. wg (1.2 - 2.1 kPa) - differential pressure

Velocity: 3900 - 5150 fpm (19.8 - 26.2 m/s)

Temperature: Minimum: -20°F (-29°C)
 Maximum with seals: 200°F (93°C)
 Maximum without seals: 250°F (121°C)
 Consult factory for temp. above 250°F (121°C)

Standard Construction

	Standard	Optional
Frame Material	Galvanized Steel	304SS or 316SS
Frame Type	Flanged Channel	
Frame Gauge	14 ga. (2mm)	10 ga. (3.5mm) 12 ga. (2.7mm)
Frame Depth	8 in. (203mm)	8 in. - 12 in. (203mm - 305mm)
Blade Material	Galvanized Steel	304SS or 316SS
Blade Type	2V	
Blade Gauge	16 ga. (1.5mm)	
Blade Seals	TPE	None
Flange Width	2 in. (51mm)	1 1/2 in. - 4 in. (38mm - 102mm)
Axle Bearing	Galvanized Steel Ball	Acetal with SS Ball
Axle Diameter	3/8 in. (9.5mm)	-
Axle Material	Plated Steel	304SS or 316SS
Linkage	External heavy duty type with galvanized steel clevis arms and plated steel tie bars & pivot pins with nylon pivot bearings	304SS or 316SS
Flow Direction	Horizontal	Vertical Up, Vertical Down, Angular Up, Angular Down
Paint Finishes	Mill Finish	Permatector™, Epoxy, Hi Pro Polyester, Industrial Epoxy

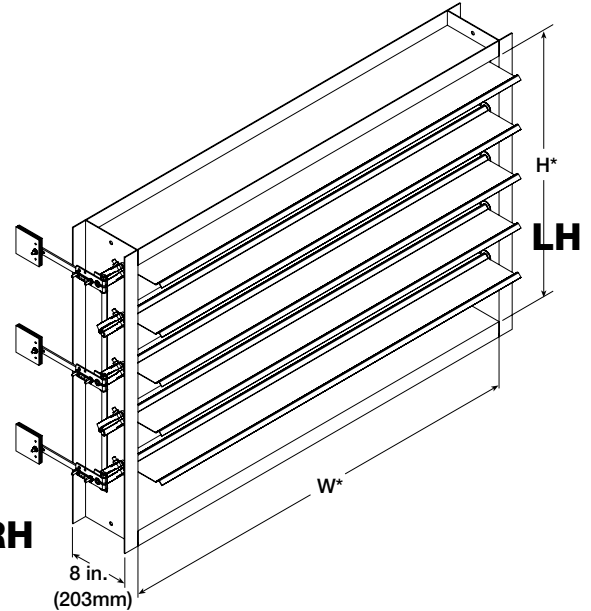

- * Actual Inside Dimension.
- ** The W dimension is ALWAYS parallel with the damper blade length.
- *** RH counterbalance is standard.
- **** Counterbalance weights extend beyond inlet flange in the open position.

Counterbalance Weight Dimensions

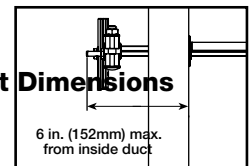
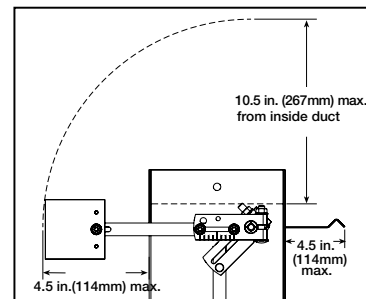

Front View

Side View

Size Limitations

W x H	Minimum Size	Maximum Size	
		Single Section	Multiple Section
Inches	6 x 6	48 x 96	96 x 96
mm	152 x 152	1219 x 2438	2438 x 2438

Advise flow direction & counterbalance weight location when ordering

Options:

- Mounting holes in both flanges

Installation instructions available at www.greenheck.com

PERFORMANCE DATA

HB-120

Pressure Limitations

The chart at the right shows conservative pressure limitations based on a maximum blade deflection of $w/360$.

Temperature Limitations

TPE blade seals: -20°F to + 200°F (-29°C to 93°C)
 No seals: -20°F to +250°F (-29°C to 121°C)

For higher temperatures consult Greenheck

Velocity Limitations

The chart at far right shows conservative velocity limitations based on damper size.

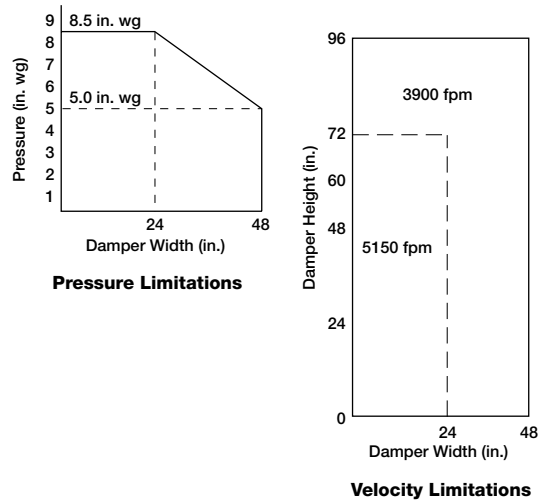

Pressure Drop Data

This pressure drop data was conducted in accordance with AMCA Standard 500-D using the three configurations shown. All data has been corrected to represent standard air at a density of 0.075 lb/ft³ (1.2 kg/m³).

Actual pressure drop found in any HVAC system is a combination of many factors. This pressure drop information along with an analysis of other system influences should be used to estimate actual pressure losses for a damper installed in a given HVAC system.

AMCA Test Figures

Figure 5.3

Illustrates a fully ducted damper. This configuration has the lowest pressure drop of the three test configurations because entrance and exit losses are minimized by straight duct runs upstream and downstream of the damper.

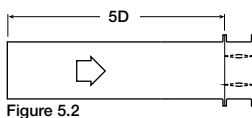
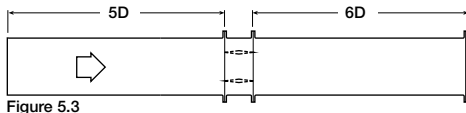

$$D = \sqrt{\frac{4(W)(H)}{3.14}}$$

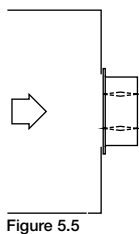

Figure 5.2

Illustrates a ducted damper exhausting air into an open area.

This configuration has a lower pressure drop than Figure 5.5 because the entrance losses are minimized by a straight duct run upstream of the damper.

Figure 5.5 illustrates a plenum mounted damper. This configuration has the highest pressure drop because of the high entrance and exit losses due to the sudden changes of area in the system.

Leakage Data

Leakage testing was conducted in accordance with AMCA Standard 500-D and is expressed as CFM per sq.ft. of damper face area. All data has been corrected to represent standard air at a density of 0.075 lb/ft³ (1.2 kg/m³).

Pressure Drop 36 in. x 36 in. (914mm x 914mm) Damper

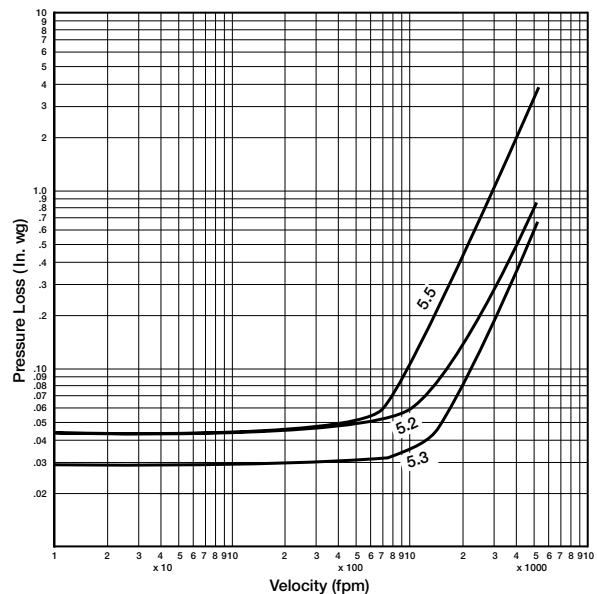

Leakage

36 in. x 36 in. (914mm x 914mm) Damper

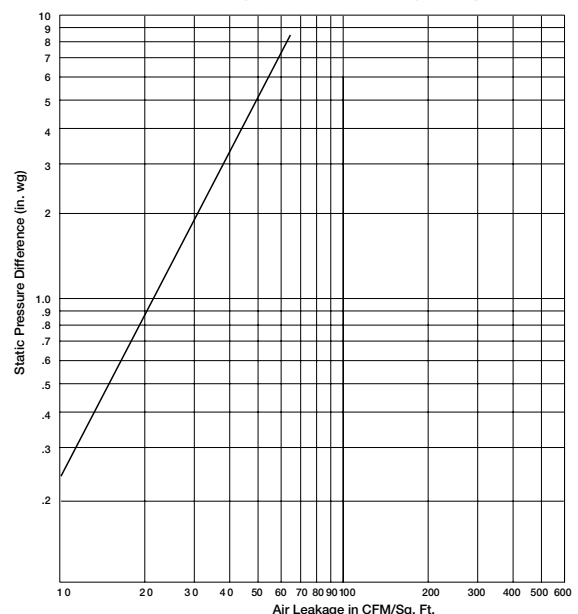

Mounting Hole Option		
	Standard	Optional
Mounting Holes in Flanges	None	Greenheck standard pattern (7/16 in. [11mm] diameter holes, spaced 6 in. [130mm] on center) or Customer Specified within limits shown in table below.

Multiple Section Assembly

Damper sizes larger than 48 in. x 96 in. (1219mm x 2438mm) and less than 96 in. x 96 in. (2438mm x 2438mm) will be supplied in one frame with two sets of blades separated by a mullion as shown below. Counterbalance weights supplied on right hand and left hand side. For sizes larger than 96 in. x 96 in. (2438mm x 2438mm) consult factory.

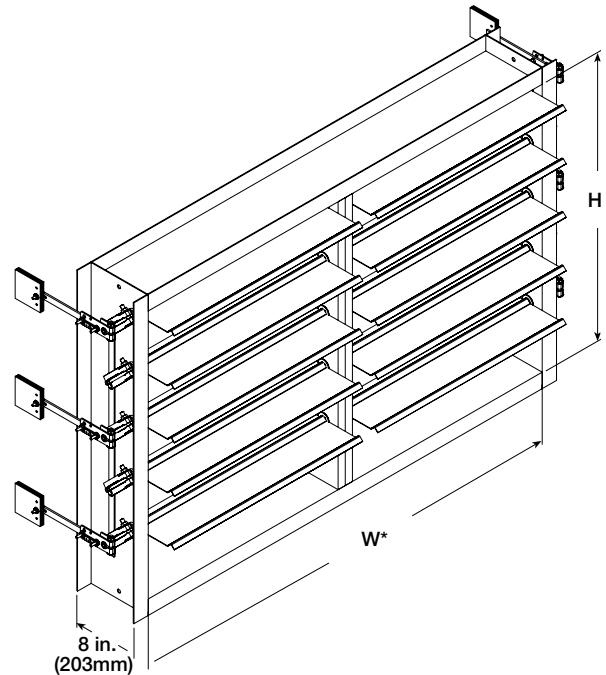
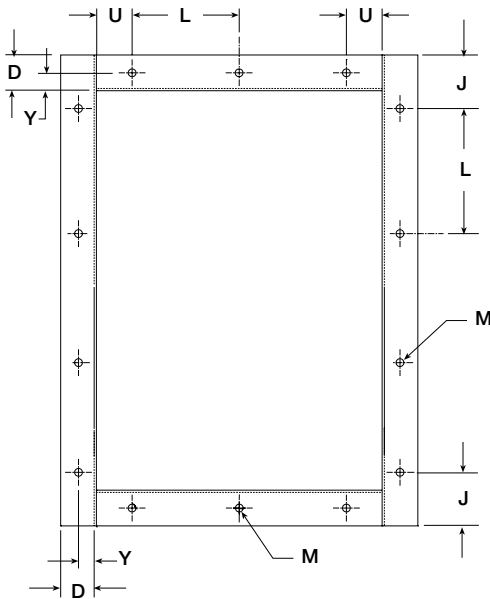

Dimension	Standard	Minimum/Maximum	Description
J		D/2 minimum	First/Last Space in Jamb
F		1 minimum	No. of Holes in Jamb
L	6 in. (152mm)	2 in. - 12 in. (51mm - 305mm)	Hole Spacing
M	7/16 in. (11mm)	1/4 in. - 11/16 in. (6mm - 17mm)	Mounting Hole Diameter
U		3/4 in. (19mm) minimum	First/Last Space in Head/Sill
V		1 minimum	No. of Holes in Head/Sill
Y	D/2 in.	3/4 in./D-3/4 in. (19mm/D-19mm)	Centerline of bolt hole from inside edge of frame

Specifications

Industrial grade backdraft dampers meeting the following specifications shall be furnished and installed where shown on plans and/or as described in schedules.

Dampers shall consist of: a 14 ga. (2mm) galvanized steel channel frame with 8 in. (203mm) minimum depth and 2 in. (51mm) flanges; double V type blades fabricated from 16 ga. (1.5mm) galvanized steel; 3/8 in. (9.5mm) dia. plated steel axles turning in galvanized steel ball bearings press fit into frame; and external (out of the airstream) heavy duty linkage with counterbalance weights.

Damper manufacturer's printed application and performance data including pressure, velocity and temperature limitations shall be submitted for approval showing damper suitable for pressures to 8.5 in. wg (2.1 kPa), velocities to 5150 fpm (26.2 m/s) and temperatures to 250°F (121°C). Testing and ratings to be in accordance with AMCA Standard 500-D.

Basis of design is Greenheck model HB-120.

