

Wind-Driven Rain Louver Vertical Blade

Application and Design

EVH-401 is a Wind-Driven Rain louver designed to protect air intake and exhaust openings in building exterior walls that are sensitive to direct water penetration. Design incorporates a drainable head member and vertical rain resistant blades to provide maximum resistance to wind driven rain in even the most extreme weather conditions. The EVH-401 is an **AMCA CERTIFIED LOUVER** enabling designers to select and apply with confidence.



Standard Construction

Frame Heavy gauge extruded 6063-T5 aluminum, 4 in. x 0.081 in. nominal wall thickness

Blades Vertical rain resistant style, heavy gauge extruded 6063-T5 aluminum, 0.081 in. nominal wall thickness, positioned on approximately 1.5 in. blade spacing

Construction . . . Mechanically fastened

Birdscreen 3/4 in. x 0.051 in. flattened expanded aluminum in removable frame, inside mount (rear)

Finish Mill

Sill Pan 0.063 formed aluminum

Minimum Size . . . 12 in. W x 12 in. H

Maximum Single

Section Size . . . 60 in. W x 96 in. H

Options (at additional cost)

- A variety of bird and insect screens
- Blank-off panel
- Clip angles
- Filter rack
- Flanged frame (*head and jamb only*)
- Security bars
- A variety of architectural finishes including:
 - Clear anodize
 - Integral color anodize
 - Baked enamel
 - Kynar

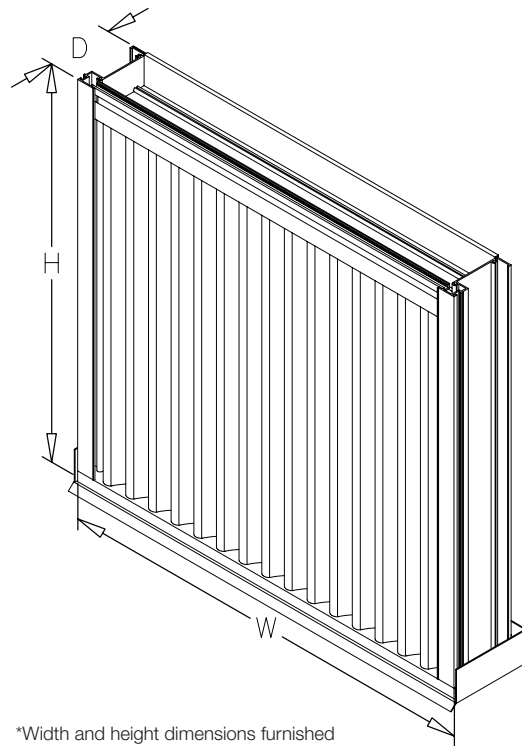
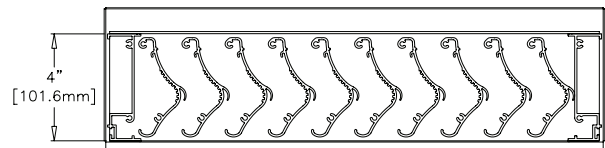

*Width and height dimensions furnished approximately 1/4 inch under size.

Wind-Driven Rain Performance

Ventilation Air Core Velocity m/s (fpm)	75mm/h (3 in/hr) Rainfall & 13 m/s (29 mph) Wind Velocity		200mm/h (8 in/hr) Rainfall & 22 m/s (50 mph) Wind Velocity		
	Water Penetration Effectiveness %	Water Penetration Classification	Ventilation Air Core Velocity m/s (fpm)	Water Penetration Effectiveness %	Water Penetration Classification
0.0 (0)		A	0.0 (0)		A
0.5 (98)		A	0.5 (98)		A
1.0 (197)		A	1.0 (197)		A
1.5 (295)		A	1.5 (295)		A
2.0 (394)		A	1.9 (365)	99.9	A
2.5 (492)		A	2.4 (473)	99.9	A
3.0 (591)		A	2.9 (570)	99.7	A
3.4 (673)	100.0	A	3.5 (694)	98.8	B

Discharge Loss Coefficient Classifications	
Class	Discharge Loss Coefficient
1	0.4 and Above
2	0.3 to 0.399
3	0.2 to 0.299
4	0.199 and Below

Wind-driven Rain Penetration Classes	
Class	Effectiveness
A	1 to 0.99
B	0.989 to 0.95
C	0.949 to 0.80
D	Below 0.80

Discharge Loss Coefficient Class (Intake) = 3

Weather louvers shall be classified by their ability to reject simulated rain. The table shows different classifications based on the maximum simulated rain penetration per square meter (square feet) of louver. Water penetration rating at a given louver face velocity is determined by the water penetration while the louver is subjected to a selected simulated rainfall rate and wind velocity.



Greenheck Fan Corporation certifies that the EVH-401 louvers shown herein are licensed to bear the AMCA Seal. The ratings shown are based on tests and procedures performed in accordance with AMCA Publication 511 and comply with the requirements of the AMCA Certified Ratings Program. The AMCA Certified Ratings Seal applies to air performance, water penetration, and wind-driven rain ratings.

Airflow Resistance (Standard Air - .075 lb/ft³)

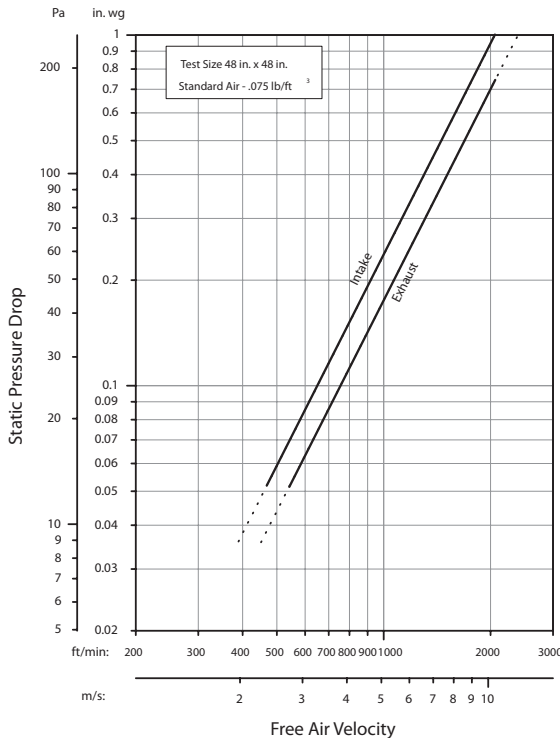

Model EVH-401 resistance to airflow (pressure drop) varies depending on louver application (air intake or air exhaust). Free area velocities (shown) are higher than average velocity through the overall louver size. See louver selection information.

Water Penetration

Test Size 48 in. x 48 in. Test Duration of 15 min.

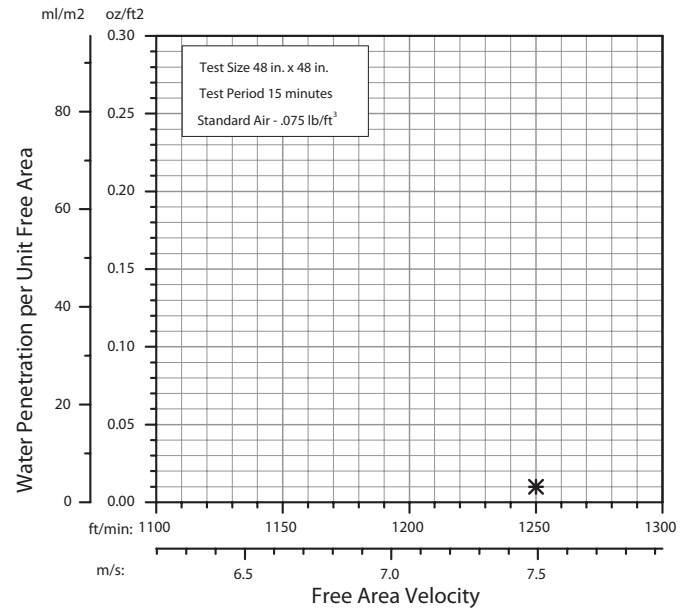

The AMCA Water Penetration Test provides a method for comparing various louver models and designs as to their efficiency in resisting the penetration of rainfall under specific laboratory test conditions. The beginning point of water penetration is defined as that velocity where the water penetration curve projects through 0.01 oz. of water (penetration) per sq. ft. of louver free area. ***The beginning point of water penetration for Model EVH-401 is above 1250 fpm free area velocity.** These performance ratings do not guarantee a louver to be weather-proof or stormproof and should be used in combination with other factors including good engineering judgement in selecting louvers.

PERFORMANCE DATA

EVH-401

Wind-Driven Rain Louver
Extruded Aluminum

Free Area Chart (sq. ft.)

Louver Height Inches	Louver Width in Inches								
	12	18	24	30	36	42	48	54	60
12	0.14	0.29	0.43	0.54	0.69	0.83	0.98	1.08	1.23
18	0.28	0.56	0.83	1.04	1.32	1.6	1.88	2.09	2.36
24	0.41	0.82	1.23	1.54	1.96	2.37	2.78	3.09	3.5
30	0.55	1.09	1.64	2.04	2.59	3.13	3.68	4.09	4.63
36	0.68	1.36	2.04	2.54	3.22	3.9	4.58	5.09	5.77
42	0.81	1.62	2.44	3.05	3.86	4.67	5.48	6.09	6.9
48	0.95	1.89	2.84	3.55	4.49	5.44	6.38	7.09	8.04
54	1.08	2.16	3.24	4.05	5.13	6.2	7.28	8.09	9.17
60	1.21	2.43	3.64	4.55	5.76	6.97	8.19	9.09	10.31
66	1.35	2.69	4.04	5.05	6.39	7.74	9.09	10.1	11.44
72	1.48	2.96	4.44	5.55	7.03	8.51	9.99	11.1	12.58
78	1.61	3.23	4.84	6.05	7.66	9.28	10.89	12.1	13.71
84	1.75	3.49	5.24	6.55	8.3	10.04	11.79	13.1	14.85
90	1.88	3.76	5.64	7.05	8.93	10.81	12.69	14.1	15.98
96	2.01	4.03	6.04	7.55	9.56	11.58	13.59	15.1	17.12

Core Area Chart (sq. ft.)

Louver Height Inches	Louver Width in Inches								
	12	18	24	30	36	42	48	54	60
12	0.57	0.95	1.32	1.70	2.07	2.45	2.82	3.20	3.57
18	0.95	1.58	2.20	2.83	3.45	4.08	4.70	5.33	5.95
24	1.33	2.21	3.08	3.96	4.83	5.71	6.58	7.46	8.33
30	1.71	2.84	3.96	5.09	6.21	7.34	8.46	9.59	10.71
36	2.09	3.47	4.84	6.22	7.59	8.97	10.34	11.72	13.09
42	2.47	4.10	5.72	7.35	8.97	10.06	21.62	13.85	15.47
48	2.85	4.73	6.60	8.48	10.35	12.23	14.10	15.98	17.85
54	3.23	5.36	7.48	9.61	11.73	13.86	15.98	18.11	20.23
60	3.61	5.99	8.36	10.74	13.11	15.49	17.86	20.24	22.61
66	3.99	6.62	9.24	11.87	14.49	17.12	19.74	22.37	24.99
72	4.37	7.25	10.12	13.00	15.87	18.75	21.62	24.50	27.37
78	4.75	7.88	11.00	14.13	17.25	20.38	23.50	26.63	29.75
84	5.13	8.51	11.88	15.26	18.63	22.01	25.38	28.76	32.13
90	5.51	9.14	12.76	16.39	20.01	23.64	27.26	30.89	34.51
96	5.89	9.77	13.64	17.52	21.39	25.27	29.14	33.02	36.89

Maximum Size and Installation Information

Maximum single section size for model EVH-401 is 60 in. W x 96 in. H. Larger openings require field assembly of multiple louver panels to make up the overall opening size. Individual louver panels are designed to withstand a 25 PSF wind-load (please consult Greenheck if the louvers must withstand higher wind-loads). Structural reinforcing members may be required to adequately support and install multiple louver panels within a large opening. Structural reinforcing members along with any associated installation hardware is not provided by Greenheck unless indicated otherwise by Greenheck. Additional information on louver installation may be found in AMCA Publication #501, Louver Application Manual.

SINGLE SECTION

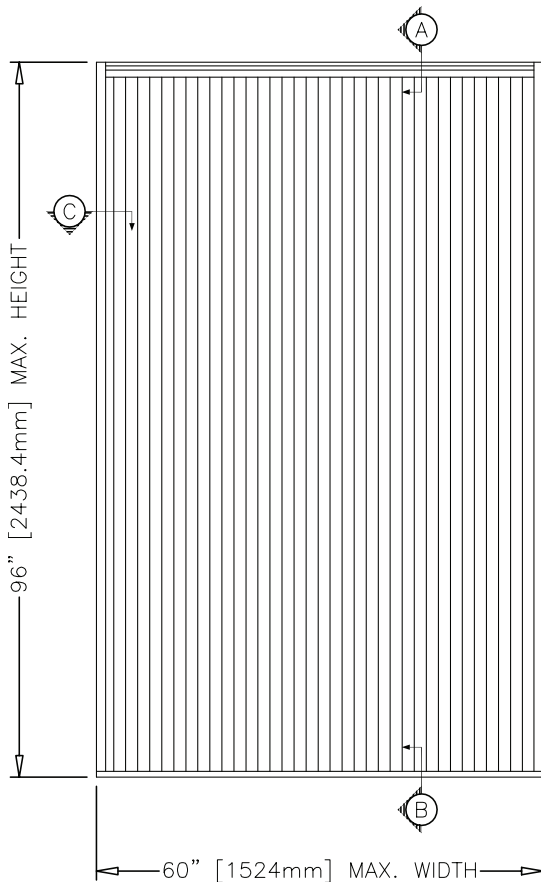

MULTIPLE SECTION
W/ MULLION

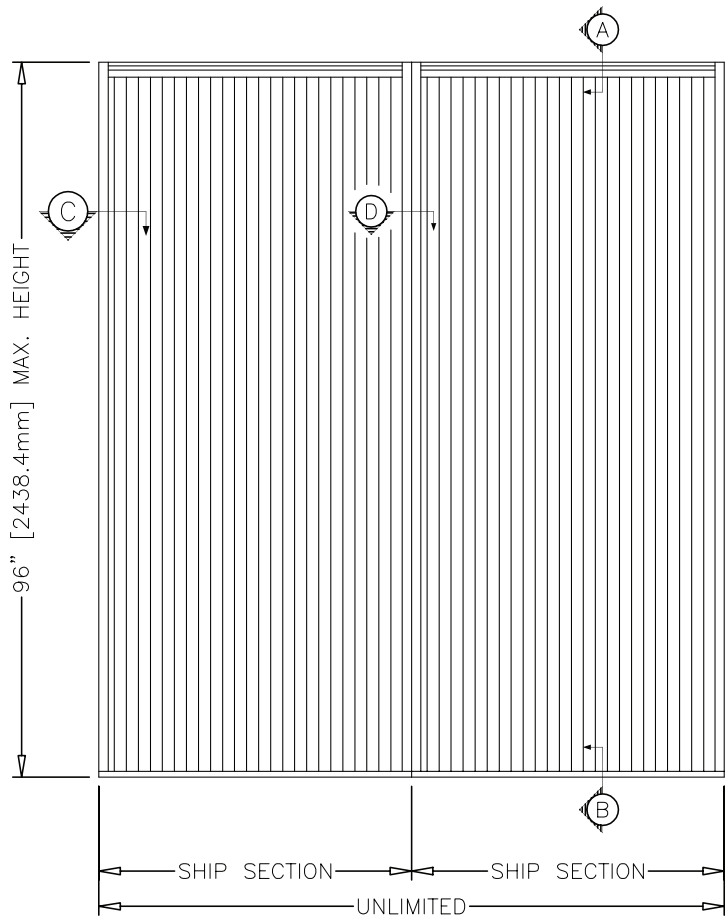

Minimum Single Section Size
12 in. W x 12 in. H

Maximum Single Section Size
60 in. W x 96 in. H

PRODUCT DETAILS

EVH-401

Wind-Driven Rain Louver
Extruded Aluminum

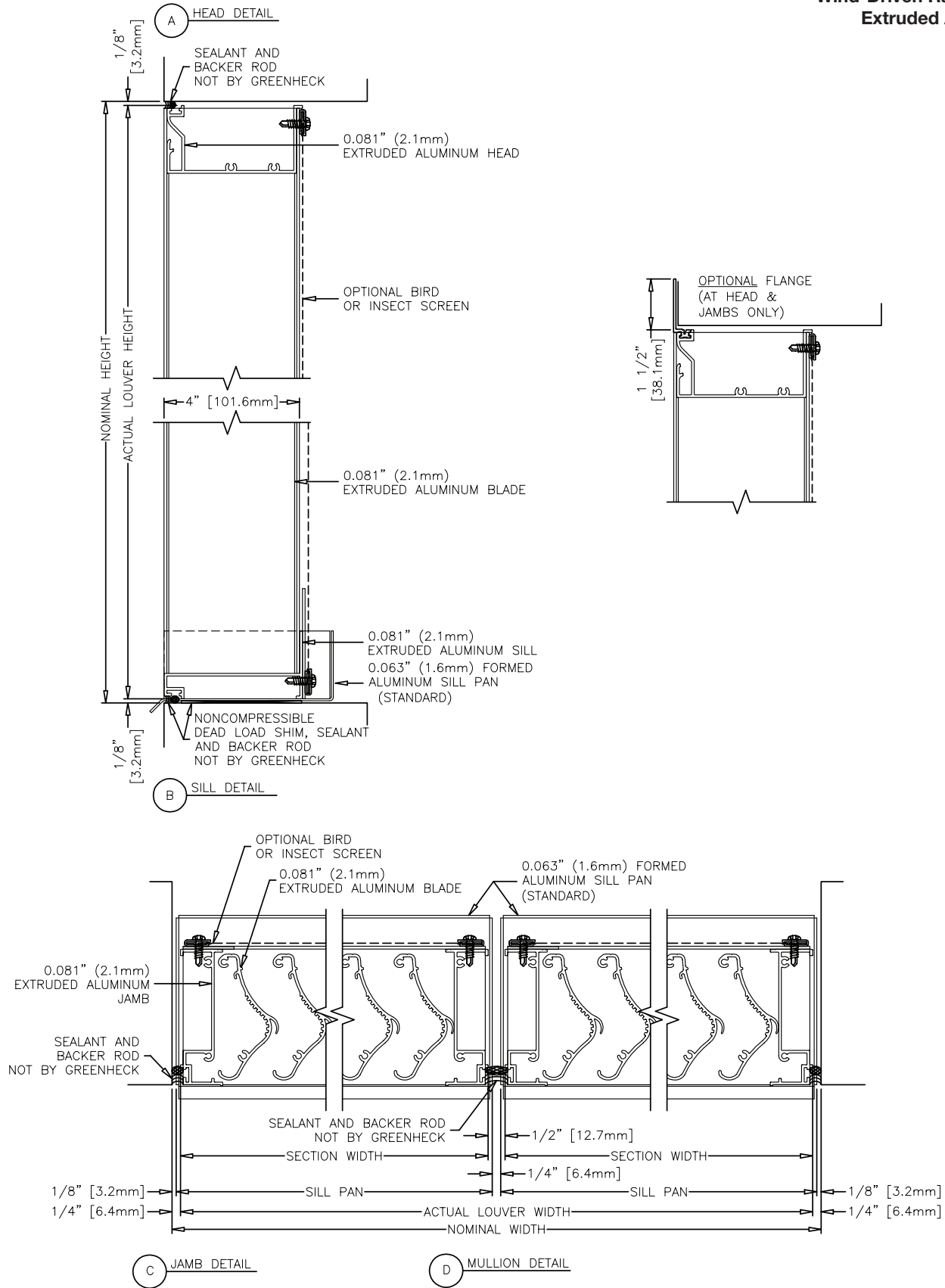

OPTION DRAWINGS

EVH-401

Wind-Driven Rain Louver
Extruded Aluminum

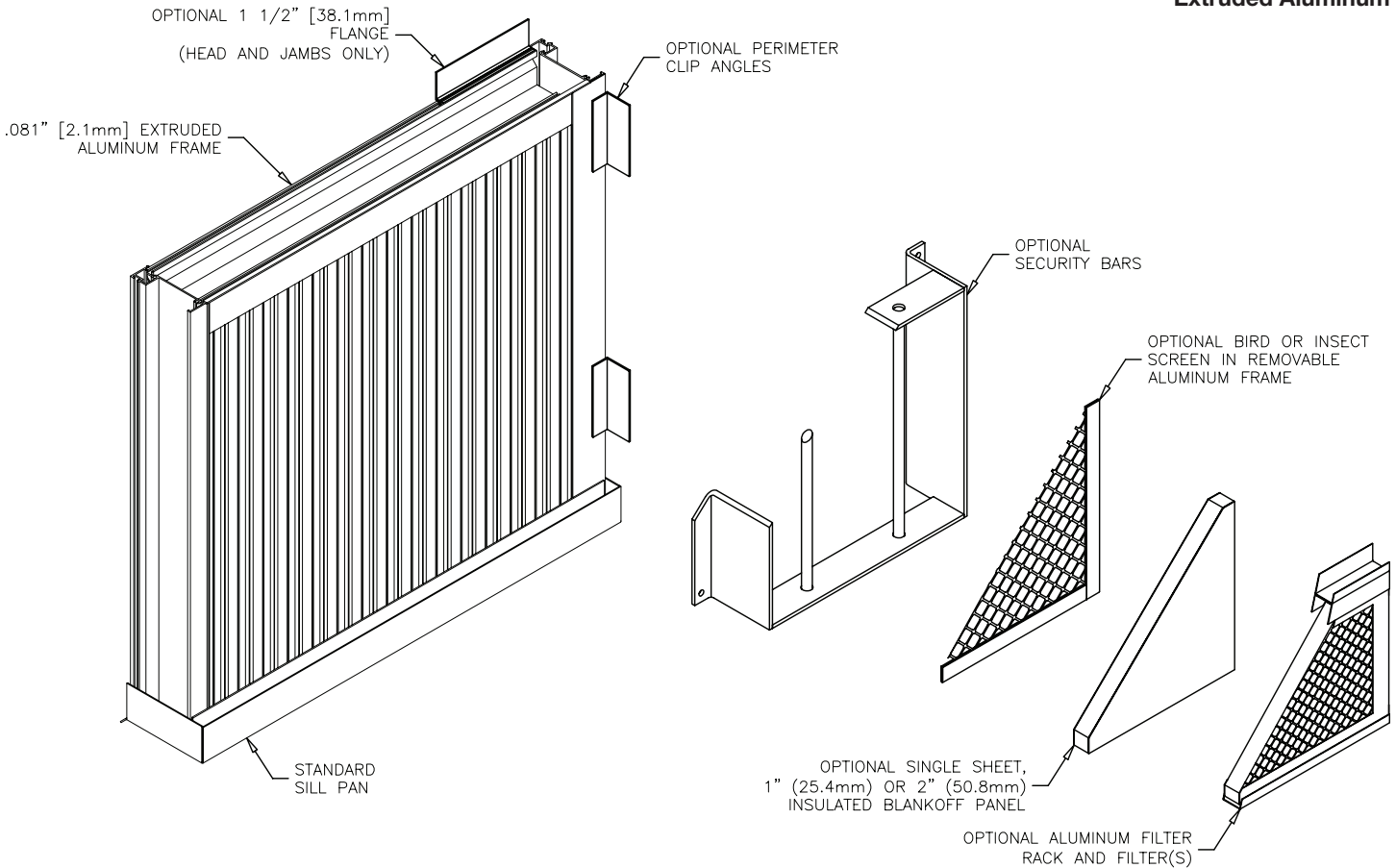

FINISHES

Finish Type	Description/Application	Color Selection	Standard Warranty (Aluminum)
2-coat 70% KYNAR 500®/HYLAR 5000® AAMA 2605 – Dry film thickness 1.2 mil. (AKA: Duranar®, Fluoropon®, Trinar®, Fluoropolymer, Polyvinylidene Fluoride, PVDF2)	"Best." The premier finish for extruded aluminum. Tough, long-lasting coating has superior color retention and abrasive properties. Resists chalking, fading, chemical abrasion and weathering.	Standard Colors: Any of the 24 standard colors shown can be furnished in 70% or 50% KYNAR 500®/HYLAR 5000® or Baked Enamel. 2-Coat Mica: Greenheck offers 9 standard 2-coat Mica colors. Other colors are available. Consult Greenheck for possible extra cost when selecting non-standard colors or special finishes.	10 Years (Consult Greenheck for availability of extended warranty)
2-coat 50% KYNAR 500®/HYLAR 5000® AAMA 2604 – Dry film thickness 1.2 mil. (AKA: Acroflur®, Acrynar®)	"Better." Tough, long-lasting coating has excellent color retention and abrasive properties. Resists chalking, fading, chemical abrasion and weathering.		5 Years
Baked Enamel AAMA 2603 – Dry film thickness 0.8 mil. (AKA: Acrabond Plus®, Duracron®)	"Good." Provides good adhesion and resistance to weathering, corrosion and chemical stain.		1 Year
Integral Color Anodize AA-M10C22A42 (>0.7 mil)	"Two-step" anodizing is produced by following the normal anodizing step with a second, colorfast process.	Light, Medium or Dark Bronze; Champagne; Black	5 years
Clear Anodize 215 R-1 AA-M10C22A41 (>0.7 mil)	Clear, colorless and hard oxide aluminum coating that resists weathering and chemical attack.	Clear	5 years
Clear Anodize 204 R-1 AA-M10C22A31 (0.4-0.7 mil)	Clear, colorless and hard oxide aluminum coating that resists weathering and chemical attack.	Clear	1 Year
Industrial coatings	Greenheck offers a number of industrial coatings such as Hi-Pro Polyester, Epoxy, and Permator®. Consult a Greenheck Product Specialist for complete color and application information.		Consult Greenheck
Mill	Materials may be supplied in natural aluminum or galvanized steel finish when normal weathering is acceptable and there is no concern for color or color change.		n/a

Finishes meet or exceed AAMA 2605, AAMA 2604, and AAMA 2603 requirements. Please consult www.greenheck.com for complete information on standard and extended paint warranties. Paint finish warranties are not applicable to steel products.



EVH-401
July 2008 Rev. 2

Copyright © 2008 Greenheck Fan Corporation

Greenheck Fan Corporation reserves the right to make product changes without notice.