

Intake/Discharge Specialty Louver Stationary Blades

Application and Design

ESID-430 is a specialty louver designed to protect air intake and exhaust openings in building exterior walls. Design incorporates a drainable head member with exhaust blades at the top and weather protective intake blades at the bottom. The blade configuration allows intake and discharge ductwork to be connected to the back of the louver and prevents the short cycling of air. Unit is available as either a combination intake/discharge louver or discharge only louver.

Standard Construction

Frame Heavy gauge extruded 6063-T5 aluminum, 4 in. x 0.081 in. nominal wall thickness

Discharge

Blades Heavy gauge extruded 6063-T5 aluminum, 0.081 in. nominal wall thickness

Intake

Blades K style, heavy gauge extruded 6063-T5 aluminum, 0.081 in. nominal wall thickness, positioned at 30° on approximately 3 in. centers

Construction . . . Mechanically fastened

Birdscreen 3/4 in. x 0.051 in. flattened expanded aluminum in removable frame, inside mount (rear)

Finish Mill

Minimum Size . . 12 in. W x 18 in. H

Maximum Single

Section Size . . . 60 in. W x 120 in. H

Options (at additional cost)

- A variety of bird and insect screens
- Blank off panel
- Clip angles
- Extended sill
- Filter rack
- Flanged frame
- Glazing adaptor
- Hinged frame
- Welded construction
- 0.125 nominal wall thickness (*frame only*)
- A variety of architectural finishes including:
 - Clear anodize
 - Integral color anodize
 - Baked enamel paint
 - Kynar paint

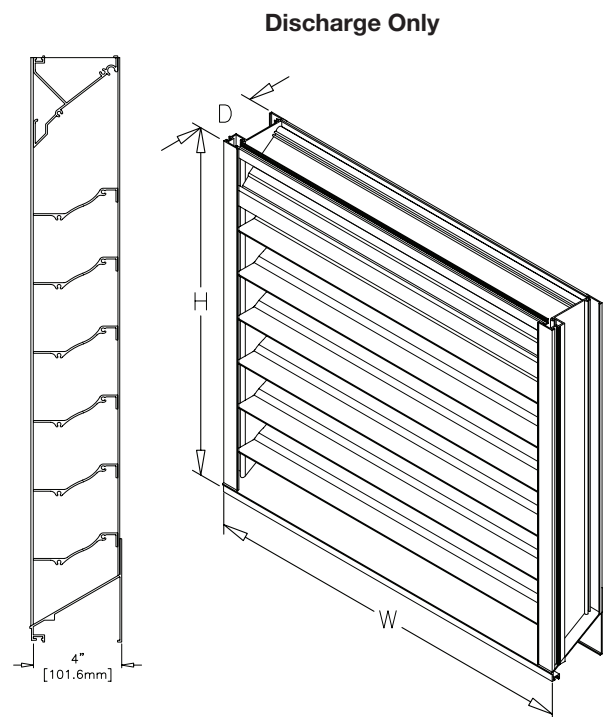
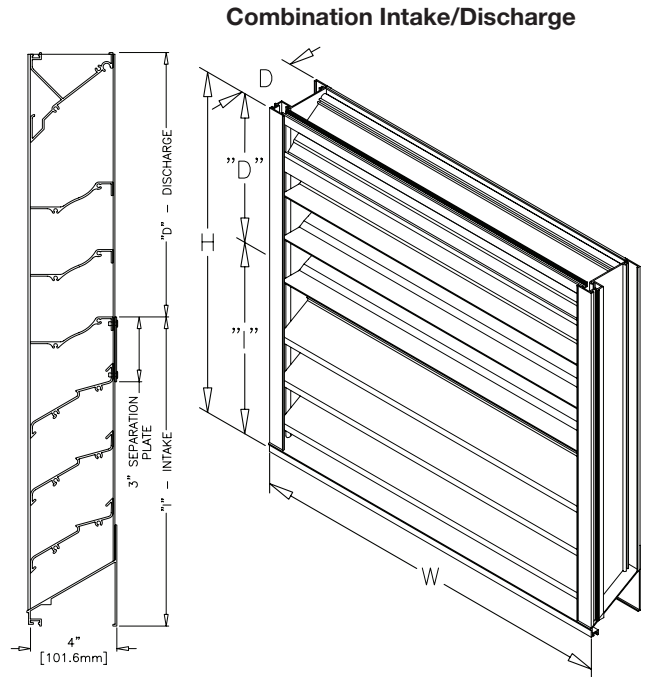

*Width and height dimensions furnished approximately 1/4 inch under size.

PERFORMANCE DATA

ESID-430

Intake/Discharge Specialty Louver
Extruded Aluminum

Free Area Chart (Sq. ft.)

Intake Dimensions

Intake Height Inches	Louver Width in Inches								
	12	18	24	30	36	42	48	54	60
12	0.18	0.29	0.41	0.52	0.64	0.73	0.84	0.96	1.07
18	0.42	0.69	0.96	1.23	1.50	1.70	1.97	2.24	2.51
24	0.65	1.07	1.50	1.92	2.34	2.66	3.08	3.50	3.93
30	0.89	1.46	2.04	2.62	3.19	3.62	4.20	4.78	5.35
36	1.12	1.85	2.76	3.30	4.03	4.58	5.30	6.03	6.76
42	1.37	2.26	3.15	4.04	4.93	5.59	6.48	7.37	8.26
48	1.62	2.67	3.72	4.77	5.82	6.61	7.66	8.71	9.76
54	1.87	3.08	4.29	5.50	6.72	7.63	8.84	10.05	11.26
60	2.12	3.49	4.86	6.24	7.61	8.64	10.02	11.39	12.76
66	2.34	3.96	5.38	6.90	8.42	9.56	11.08	12.60	14.12
72	2.58	4.25	5.92	7.59	9.26	10.52	12.19	13.86	15.53
78	2.81	4.64	6.46	8.28	10.11	11.48	13.30	15.12	16.95
84	3.05	5.03	7.00	8.98	10.96	12.44	14.42	16.40	18.37
90	3.29	5.42	7.55	9.68	11.82	13.41	15.55	17.68	19.81
96	3.52	5.81	8.09	10.38	12.67	14.38	16.66	18.95	21.24

Discharge Dimensions

Discharge Height Inches	Louver Width in Inches								
	12	18	24	30	36	42	48	54	60
6	0.19	0.32	0.44	0.57	0.69	0.79	0.91	1.04	1.16
9.125	0.35	0.58	0.81	1.04	1.25	1.44	1.66	1.89	2.12
12.25	0.51	0.84	1.17	1.50	1.84	2.08	2.42	2.75	3.08
15.375	0.57	1.10	1.54	1.97	2.41	2.73	3.17	3.60	4.04
18.5	0.83	1.37	1.90	2.44	2.98	3.38	3.92	4.45	5.00
21.625	0.99	1.63	2.27	2.91	3.55	4.03	4.57	5.31	5.95
24.75	1.15	1.89	2.54	3.38	4.12	4.58	5.43	6.17	6.91
27.875	1.31	2.15	3.00	3.85	4.69	5.33	6.18	7.02	7.87
31	1.47	2.42	3.37	4.32	5.27	5.98	6.93	7.88	8.83
34.125	1.52	2.58	3.73	4.78	5.84	6.63	7.58	8.74	9.79
37.25	1.78	2.94	4.10	5.25	6.41	7.28	8.43	9.59	10.75
40.375	1.94	3.20	4.45	5.72	6.98	7.93	9.19	10.45	11.71
43.5	2.10	3.45	4.83	6.19	7.55	8.58	9.94	11.30	12.66
45.625	2.25	3.73	5.19	6.55	8.13	9.22	10.59	12.16	13.62
49.75	2.42	3.99	5.55	7.13	8.70	9.87	11.44	13.01	14.58
52.875	2.58	4.25	5.92	7.50	9.27	10.52	12.20	13.87	15.54
55	2.74	4.51	6.29	8.05	9.84	11.17	12.95	14.72	16.50
59.125	2.90	4.78	6.55	8.53	10.41	11.82	13.70	15.58	17.46
62.25	3.05	5.04	7.02	9.00	10.98	12.47	14.45	16.43	18.42
65.375	3.21	5.30	7.38	9.47	11.56	13.12	15.20	17.29	19.37
68.5	3.37	5.55	7.75	9.94	12.13	13.77	15.95	18.14	20.33
71.625	3.53	5.82	8.12	10.41	12.70	14.42	16.71	19.00	21.29
74.75	3.59	6.09	8.48	10.88	13.27	15.07	17.46	19.86	22.25
77.875	3.85	6.35	8.85	11.34	13.84	15.72	18.21	20.71	23.21
81	4.01	6.61	9.21	11.81	14.41	16.36	18.97	21.57	24.17
84.125	4.17	6.87	9.58	12.28	14.99	17.01	19.72	22.42	25.13
87.25	4.33	7.14	9.94	12.75	15.55	17.55	20.47	23.28	26.08
90.375	4.49	7.40	10.31	13.22	16.13	18.31	21.22	24.13	27.04
93.5	4.55	7.55	10.57	13.59	16.70	18.96	21.97	24.99	28.00
96.625	4.81	7.92	11.04	14.15	17.27	19.61	22.73	25.84	28.95
99.75	4.96	8.18	11.40	14.62	17.84	20.26	23.48	26.70	29.92
102.875	5.12	8.45	11.77	15.09	18.42	20.91	24.23	27.55	30.88
105	5.28	8.71	12.13	15.55	18.99	21.56	24.98	28.41	31.84
109.125	5.44	8.97	12.50	16.03	19.56	22.21	25.74	29.27	32.79
112.25	5.50	9.23	12.87	16.50	20.13	22.86	25.49	30.12	33.75

Discharge Unit Only

Louver Height Inches	Louver Width in Inches								
	12	18	24	30	36	42	48	54	60
12	0.22	0.36	0.51	0.65	0.80	0.90	1.05	1.19	1.33
18	0.52	0.85	1.20	1.55	1.89	2.14	2.48	2.82	3.15
24	0.84	1.38	1.92	2.45	3.00	3.41	3.95	4.49	5.03
30	1.15	1.90	2.55	3.40	4.15	4.71	5.46	6.20	6.95
36	1.47	2.43	3.38	4.34	5.29	6.01	6.95	7.91	8.86
42	1.77	2.92	4.07	5.22	6.37	7.23	8.38	9.53	10.68
48	2.08	3.42	4.76	6.11	7.46	8.46	9.81	11.16	12.50
54	2.38	3.92	5.45	7.00	8.54	9.70	11.24	12.78	14.33
60	2.58	4.42	6.15	7.89	9.63	10.93	12.57	14.41	16.15
66	2.98	4.91	6.85	8.78	10.72	12.16	14.10	15.03	17.96
72	3.28	5.41	7.54	9.57	11.80	13.40	15.53	17.56	19.79
78	3.59	5.91	8.24	10.55	12.89	14.53	16.96	19.28	21.51
84	3.89	6.41	8.93	11.45	13.97	15.86	18.39	20.91	23.43
90	4.19	6.91	9.53	12.34	15.05	17.10	19.82	22.53	25.25
96	4.49	7.41	10.33	13.24	16.16	18.34	21.26	24.17	27.09
102	4.81	7.93	11.05	14.17	17.30	19.54	22.76	25.58	29.00
108	5.13	8.46	11.78	15.11	18.44	20.93	24.26	27.59	30.91
114	5.44	8.96	12.50	16.02	19.55	22.20	25.72	29.25	32.78
120	5.74	9.46	13.19	16.91	20.54	23.43	27.15	30.88	34.50

Airflow Resistance (Standard Air - .075 lb/ft³)

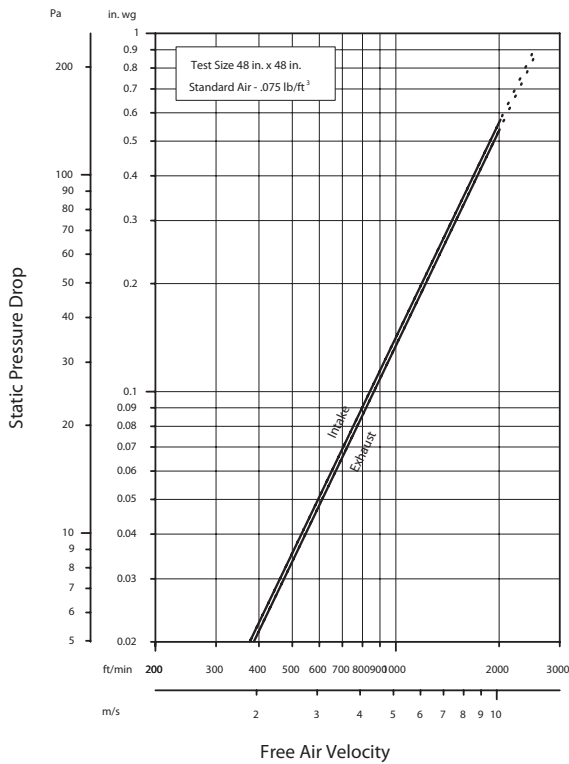

Model ESID-430 resistance to airflow (pressure drop) varies depending on louver application (air intake or air exhaust). Free area velocities (shown) are higher than average velocity through the overall louver size. See louver selection information.

This half intentionally left blank.

INSTALLATION DETAILS

ESID-430

Maximum Size and Installation Information

Intake/Discharge Specialty Louver
Extruded Aluminum

Maximum single section size for model ESID-435 is 60 in. W x 120 in. H. Larger openings require field assembly of multiple louver panels to make up the overall opening size. Individual louver panels are designed to withstand a 25 PSF wind-load (please consult Greenheck if the louvers must withstand higher wind-loads). Structural reinforcing members may be required to adequately support and install multiple louver panels within a large opening. Structural reinforcing members along with any associated installation hardware is not provided by Greenheck unless indicated otherwise by Greenheck. Additional information on louver installation may be found in AMCA Publication #501, Louver Application Manual.

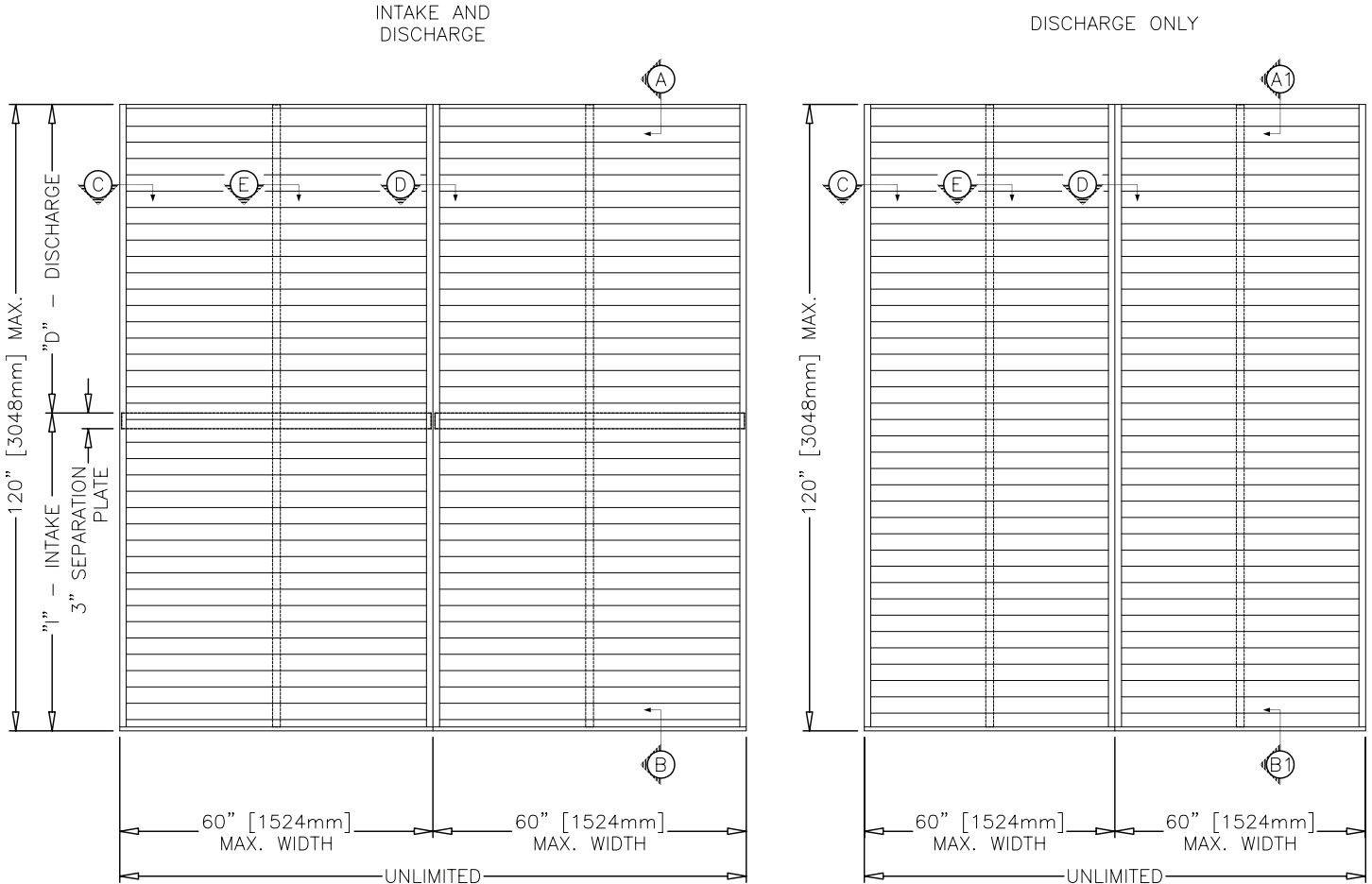

Minimum Single Section Size

12 in. W x 18 in. H

Maximum Single Section Size

60 in. W x 120 in. H

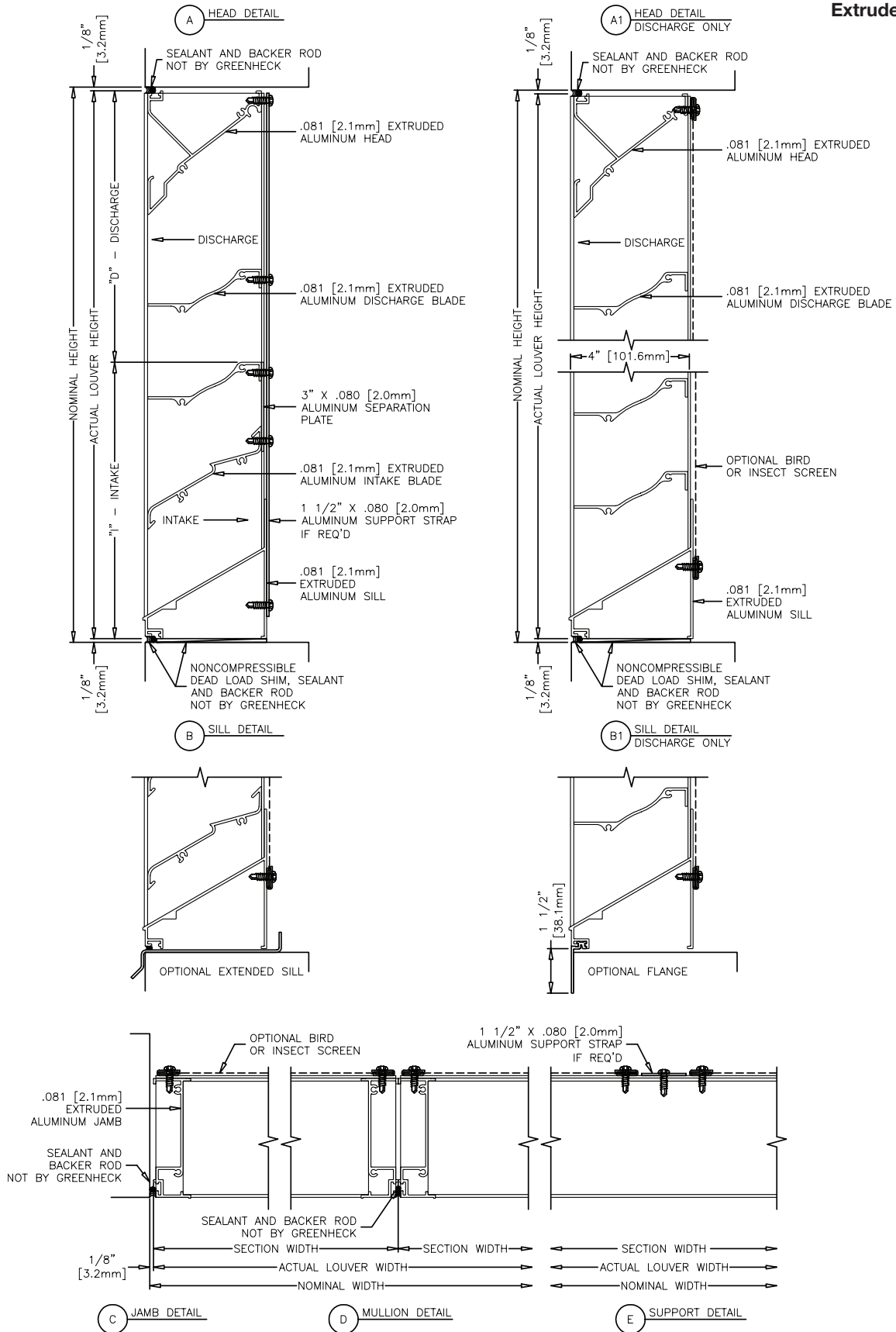

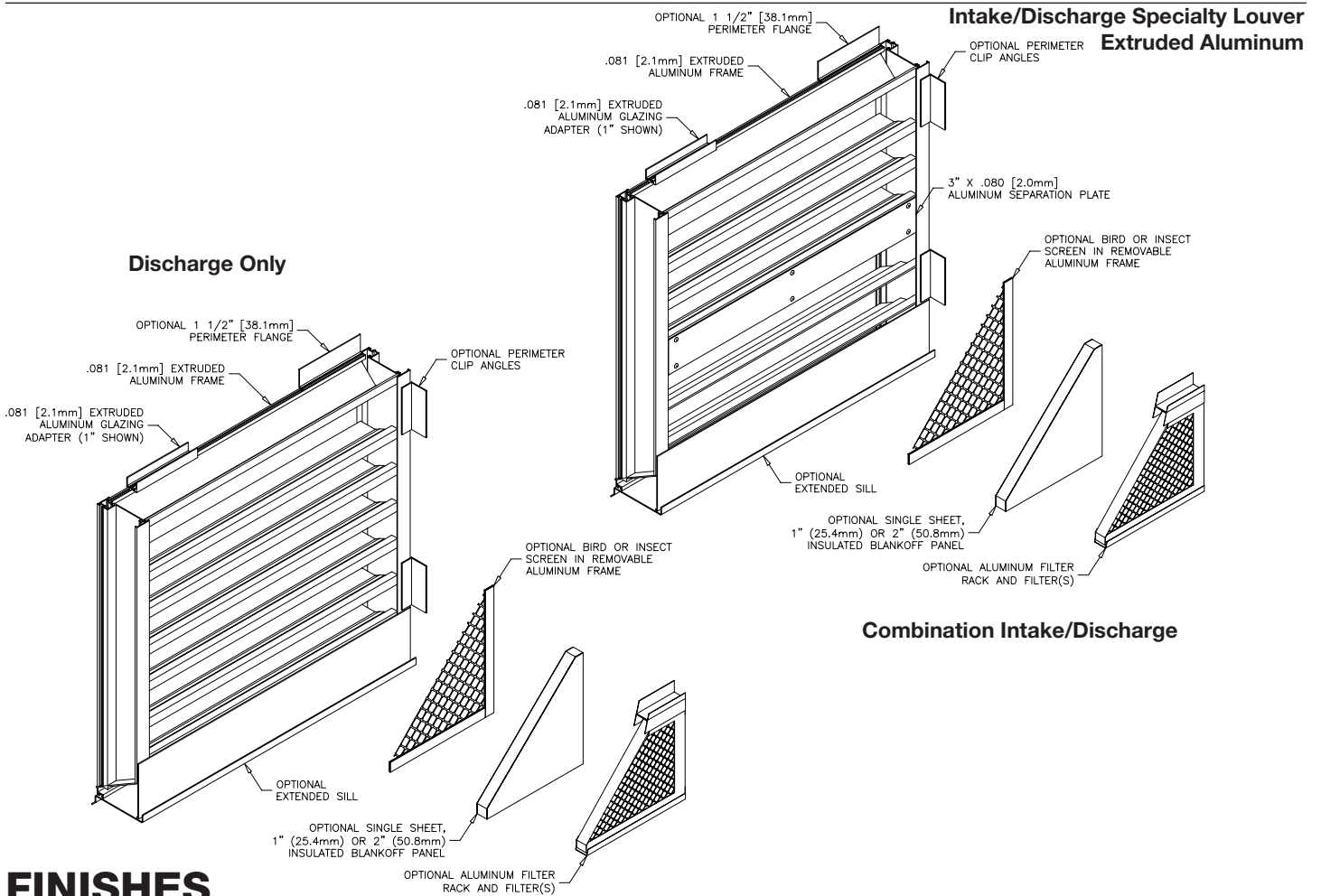

FINISHES

Finish Type	Description/Application	Color Selection	Standard Warranty (Aluminum)
2-coat 70% KYNAR 500®/HYLAR 5000® AAMA 2605 – Dry film thickness 1.2 mil. (AKA: Duranar®, Fluoropon®, Trinar®, Fluoropolymer, Polyvinylidene Fluoride, PVDF2)	“Best.” The premier finish for extruded aluminum. Tough, long-lasting coating has superior color retention and abrasive properties. Resists chalking, fading, chemical abrasion and weathering.	Standard Colors: Any of the 24 standard colors shown can be furnished in 70% or 50% KYNAR 500®/HYLAR 5000® or Baked Enamel. 2-Coat Mica: Greenheck offers 9 standard 2-coat Mica colors. Other colors are available. Consult Greenheck for possible extra cost when selecting non-standard colors or special finishes.	10 Years (Consult Greenheck for availability of extended warranty)
2-coat 50% KYNAR 500®/HYLAR 5000® AAMA 2604 – Dry film thickness 1.2 mil. (AKA: Acroflur®, Acrynar®)	“Better.” Tough, long-lasting coating has excellent color retention and abrasive properties. Resists chalking, fading, chemical abrasion and weathering.		5 Years
Baked Enamel AAMA 2603 – Dry film thickness 0.8 mil. (AKA: Acrabond Plus®, Duracron®)	“Good.” Provides good adhesion and resistance to weathering, corrosion and chemical stain.		1 Year
Integral Color Anodize AA-M10C22A42 (>0.7 mil)	“Two-step” anodizing is produced by following the normal anodizing step with a second, colorfast process.	Light, Medium or Dark Bronze; Champagne; Black	5 years
Clear Anodize 215 R-1 AA-M10C22A41 (>0.7 mil)	Clear, colorless and hard oxide aluminum coating that resists weathering and chemical attack.	Clear	5 years
Clear Anodize 204 R-1 AA-M10C22A31 (0.4-0.7 mil)	Clear, colorless and hard oxide aluminum coating that resists weathering and chemical attack.	Clear	1 Year
Industrial coatings	Greenheck offers a number of industrial coatings such as Hi-Pro Polyester, Epoxy, and Permator®. Consult a Greenheck Product Specialist for complete color and application information.		Consult Greenheck
Mill	Materials may be supplied in natural aluminum or galvanized steel finish when normal weathering is acceptable and there is no concern for color or color change.		n/a

Finishes meet or exceed AAMA 2605, AAMA 2604, and AAMA 2603 requirements. Please consult www.greenheck.com for complete information on standard and extended paint warranties. Paint finish warranties are not applicable to steel products.



ESID-430

July 2007 Rev. 3

Copyright © 2007 Greenheck Fan Corporation