

Miami-Dade Qualified Drainable Blade Louver

Application and Design

ESD-635D is an extruded aluminum stationary louver designed to protect air intake and exhaust openings in building exteriors specifically for applications requiring extremely high structural design loadings. The ESD-635d is an **AMCA CERTIFIED LOUVER** enabling designers to select and apply with confidence. Design characteristics meet the performance requirements established by the Florida Building Code and Miami-Dade County. Tested in accordance with and passes TAS 201 (Large Missile Impact), TAS 202 (Uniform Static Air Pressure) and TAS 203 (Cyclic Wind Loading). ESD-635D may be installed in locations where the space behind the louver is designed to accept water penetration and houses water resistant/water proof equipment, components or supplies. Qualified for installation within concrete/masonry, steel stud, structural steel or wood framed building conditions.

Standard Construction

- Frame** Heavy gauge extruded 6063T5 aluminum, 6 in. x 0.125 in. nominal wall thickness, front 1.5 in. flange (optional on channel frame installation)
- Blades** Drainable design, heavy gauge extruded aluminum, 0.081 in. nominal wall thickness if RO height \leq 96.788 in. or 0.125 in. if RO height $>$ 96.788 in., positioned at 37° angles on approximately 4 in. centers
- Construction** Welded and mechanically fastened
- Birdscreen** 3/4 in. x 0.051 flattened expanded aluminum in removable frame, inside mount (rear), mill finish only
- Finish** Mill
- Mounting sleeve** Heavy gauge aluminum with front flange and rear aluminum angles, mill finish only

Minimum Rough

Opening Size 12 in. W x 12 in. H

Maximum Rough Opening Size

Flange/Sleeve 1,000 in. W x 144.50 in. H

Maximum Rough Opening Size

Channel Frame 1,000 in. W x 144.50 in. H

Maximum Single Section Rough Opening Size

Flange/Sleeve 72.50 in. W x 144.50 in. H

Maximum Single Section Rough Opening Size

Channel Frame 72.75 in. W x 144.50 in. H

Options (at additional cost)

- A variety of bird and insect screens
- Flange Frame (Channel Frame Installation)
- Blank off panel
- Filter rack
- Security bars
- A variety of architectural finishes including:
 - Clear anodize
 - Integral color anodize
 - Baked enamel
 - Kynar

Flange/Sleeve Installation

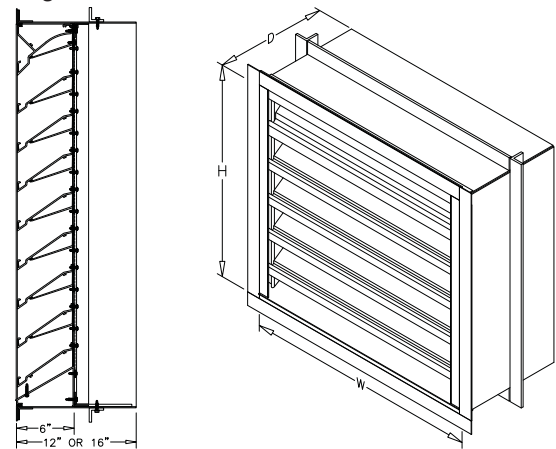

Channel Frame Installation

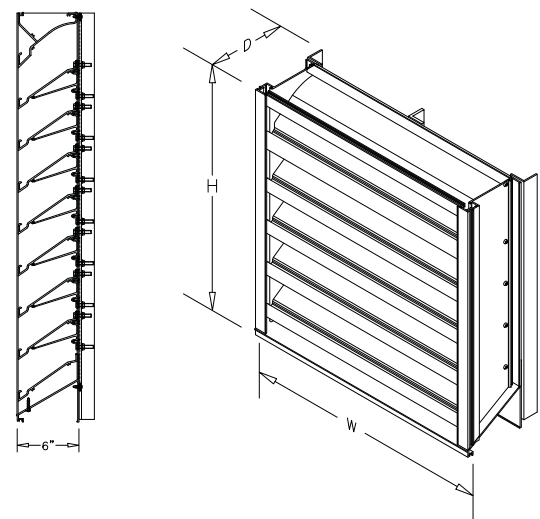

Optional factory attached VCD-40 damper

- Parallel blade action
- Plated steel blade linkage
- Silicone blade seals
- Stainless steel compression jamb seals
- 1/2 in. diameter plated steel axles
- Synthetic (acetal) sleeve bearings
- Manual quadrant actuator (in airstream)
- Mill finish only

Minimum Rough Opening Size 12 in. W x 15.25 in. H

Maximum Rough Opening Size

Flange/Sleeve 1,000 in. W x 144.50 in. H

Maximum Rough Opening Size

Channel Frame 1,000 in. W x 144.50 in. H

Maximum Single Section

Rough Opening Size/Flange/Sleeve 36.50 in. W x 144.50 in. H

Maximum Single Section

Rough Opening Size Channel Frame 36.75 in. W x 144.50 in. H

PERFORMANCE DATA

ESD-635D

Florida Product Approval No.: FL10088

Miami-Dade NOA No.: 10-0921.09

Maximum Wind-load: 150 PSF

Free Area Chart

Louver Height Inches	Louver Width in Inches										
	12	18	24	30	36	42	48	54	60	66	72
12	0.19	0.32	0.44	0.57	0.69	0.82	0.94	1.04	1.16	1.29	1.41
18	0.48	0.80	1.11	1.42	1.74	2.05	2.36	2.60	2.91	3.22	3.54
24	0.77	1.27	1.77	2.27	2.77	3.27	3.76	4.14	4.64	5.14	5.64
30	1.05	1.73	2.41	3.09	3.77	4.45	5.13	5.64	6.32	7.01	7.69
36	1.35	2.22	3.09	3.97	4.84	5.71	6.59	7.24	8.11	8.99	9.86
42	1.62	2.67	3.71	4.76	5.81	6.86	7.91	8.69	9.74	10.79	11.84
48	1.92	3.17	4.42	5.67	6.91	8.16	9.41	10.34	11.59	12.84	14.09
54	2.18	3.60	5.02	6.44	7.85	9.27	10.69	11.75	13.17	14.58	16.00
60	2.49	4.10	5.71	7.32	8.94	10.55	12.16	13.37	14.98	16.59	18.21
66	2.75	4.53	6.32	8.10	9.88	11.67	13.45	14.79	16.57	18.36	20.14
72	3.05	5.03	7.01	8.99	10.97	12.95	14.93	16.41	18.39	20.37	22.35
78	3.31	5.46	7.61	9.76	11.91	14.06	16.21	17.83	19.98	22.13	24.28
84	3.62	5.96	8.31	10.66	13.00	15.35	17.69	19.45	21.80	24.15	26.49
90	3.88	6.40	8.91	11.43	13.95	16.46	18.98	20.87	23.38	25.90	28.42
96	4.18	6.90	9.61	12.32	15.04	17.75	20.46	22.50	25.21	27.92	30.64
102	4.44	7.33	10.21	13.09	15.98	18.86	21.74	23.90	26.79	29.67	32.55
108	4.75	7.83	10.91	13.99	17.07	20.15	23.23	25.54	28.62	31.70	34.78
114	5.01	8.26	11.51	14.76	18.01	21.26	24.51	26.95	30.20	33.45	36.70
120	5.31	8.76	12.21	15.66	19.10	22.55	26.00	28.58	32.03	35.48	38.92
132	5.89	9.70	13.52	17.34	21.15	24.79	28.79	31.65	35.47	39.29	43.11
144	6.45	10.64	14.82	19.01	23.19	27.38	31.56	34.70	38.89	43.07	47.26



Greenheck Fan Corporation certifies that the ESD-635D louvers shown herein are licensed to bear the AMCA Seal. The ratings shown are based on tests and procedures performed in accordance with AMCA Publication 511 and comply with the requirements of the AMCA Certified Ratings Program. The AMCA Certified Ratings Seal applies to air performance and water penetration ratings.

Water Penetration (Standard Air - .075 lb./ft.3)

Test size 48 in. x 48 in. Test duration of 15 min.

Airflow Resistance (Standard Air - .075 lb/ft³)

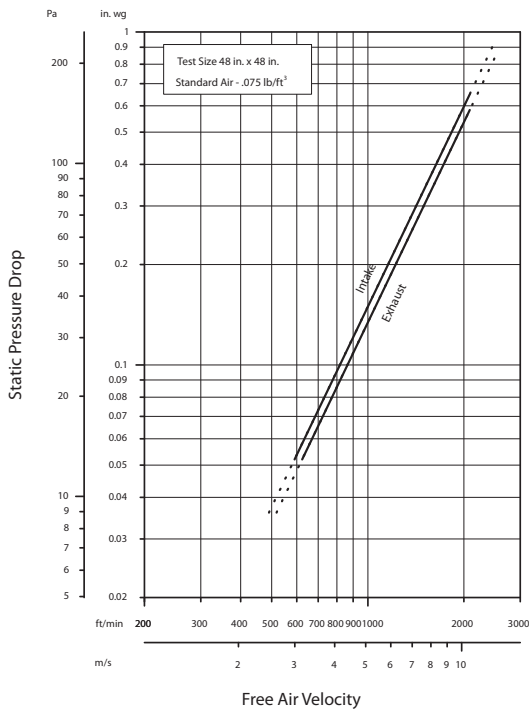

Model ESD-635D resistance to airflow (pressure drop) varies depending on louver application (air intake or air exhaust). Free area velocities (shown) are higher than average velocity through the overall louver size. See louver selection information.

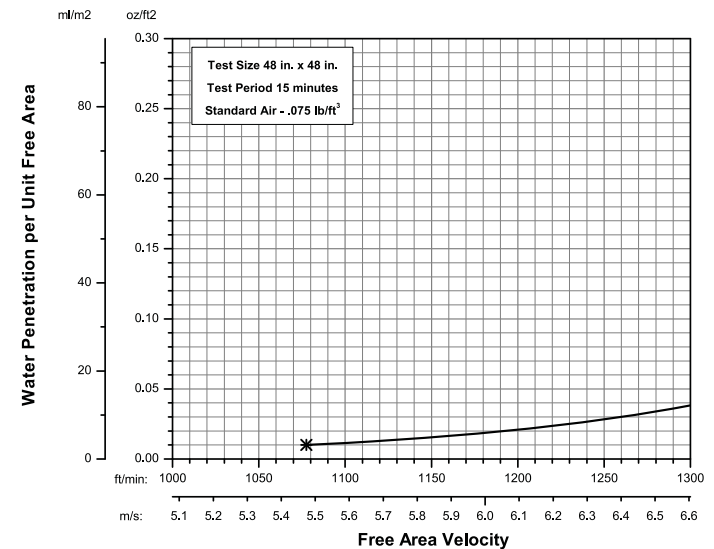

The AMCA Water Penetration Test provides a method for comparing various louver models and designs as to their efficiency in resisting the penetration of rainfall under specific laboratory test conditions. The beginning point of water penetration is defined as that velocity where the water penetration curve projects through .01 oz. of water (penetration) per sq. ft. of louver free area. ***The beginning point of water penetration for Model ESD-635D is 1077 fpm free area velocity.** These performance ratings do not guarantee a louver to be weatherproof or stormproof and should be used in combination with other factors including good engineering judgement in selecting louvers.



***AMCA licensed performance data shown herein pertains only to the louver and does not include effects of the factory attached VCD-40 damper.**

OPTION DRAWINGS

ESD-635D

Florida Product Approval No.: FL10088
 Miami-Dade NOA No.: 10-0921.09
 Maximum Wind-load: 150 PSF

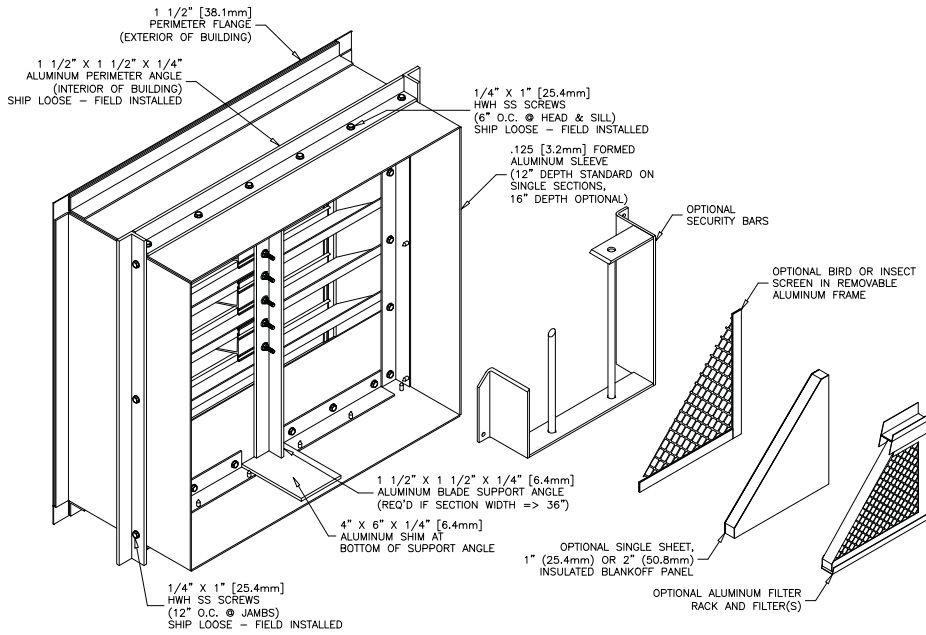

Single Section Wide Flange/Sleeve Installation

- Min. structure depth 4 in.
- Max. structure depth 10.5 in. (12 in. sleeve)
- Max. structure depth 14.5 in. (16 in. sleeve)

Single Section Wide Channel Frame Installation

- Reference the Installation, Operations and Maintenance Instructions (IOM)

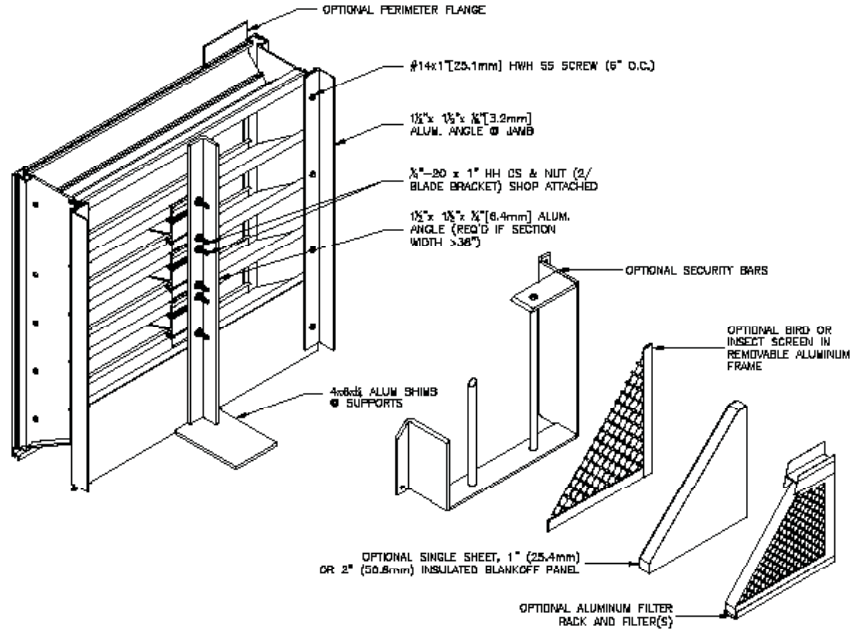

QUALIFIED SHAPES

- Only available without damper
- Only available in single section configurations
- Anodize finish is not available
- AMCA license performance data is void

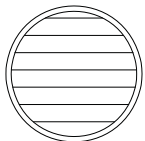

Round

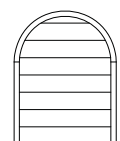

Round Top

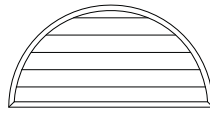

Half Round

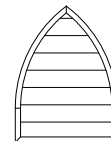

Cathedral

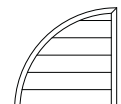

1/4 Round

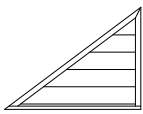

Triangle

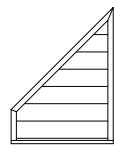

Slope Top

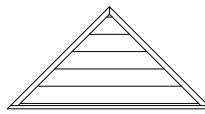

Pyramid

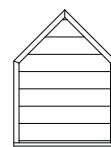

House

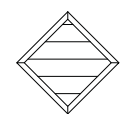

Diamond

OPTION DRAWINGS

ESD-635D with VCD-40

Florida Product Approval No.: FL10088

Miami-Dade NOA No.: 10-0921.09

Maximum Wind-load: 150 PSF

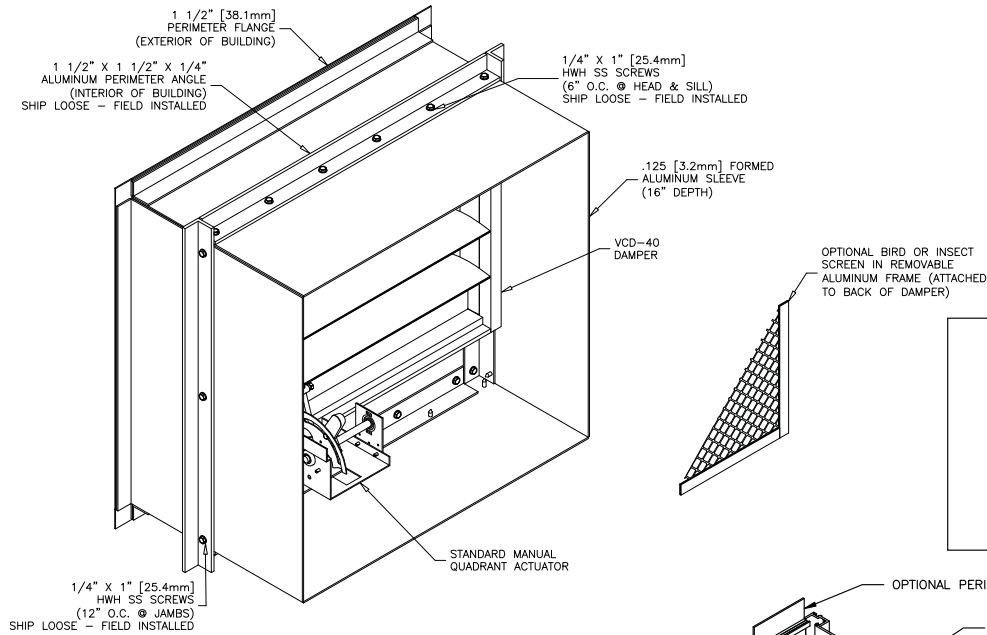

Single Section Wide Flange/Sleeve Installation with VCD-40 Damper

- Min. structure depth 4 in.
- Max. structure depth 14.5 in.

Single Section Wide Channel Frame Installation with VCD-40 Damper

- Reference the Installation, Operations and Maintenance Instructions (IOM)

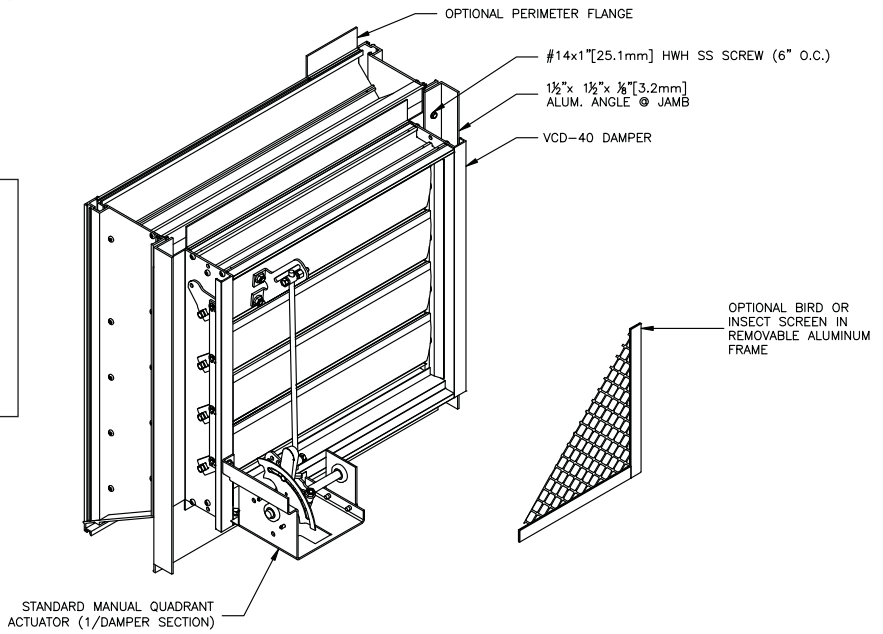

Building Condition/Substrate Limitations

Flange/Sleeve Installation

- All wood substrate shall be G= 0.55 density or better
- All metal stud substrate should be min. 16 Ga. FY= 50 KSI
- All structural steel substrate shall be min. 0.25 in. thick FY= 36 KSI
- All concrete substrate shall be min. 3000 PSI
- Concrete masonry shall be ASTM C90, Type II, 2000 PSI, grout-filled

Channel Installation

- All metal stud substrate should be min. 10 Ga. FY= 36 KSI
- All structural steel substrate shall be min. 0.125 in. thick FY= 36 KSI
- All concrete substrate shall be min. 4000 PSI (2000 PSI allowed with SDR)
- Concrete masonry shall be ASTM C90, Type II, 2000 PSI, grout-filled

For additional information, including multiple section installation details, reference the Installation, Operation and Maintenance (IOM) manuals.



ESD-635D
February 2011, Rev. 1
Copyright © 2011 Greenheck Fan Corporation

Greenheck Fan Corporation reserves the right to make product changes without notice.