

### Application and Design

Greenheck Bar Grilles are custom designed and manufactured to function as architectural accents or as entire facades to prevent sight or serve as solar screens or security barriers. Bar Grilles are manufactured in configurations from 2 in. (50.8 mm) to 6 in. (152.4 mm) deep and with extruded aluminum members that range in thicknesses from 0.081 in. (2.06 mm) to 0.250 in. (6.35 mm). Horizontal and vertical bar spacing can be configured from 2 in. (50.8 mm) minimum to 12 in. (304.8 mm) maximum center spacing to yield desired sightlines.

### Standard Construction

Material . . . . . Extruded Aluminum, Alloy 6063T5  
 Material Thickness . . . . . 0.081 to 0.250 in. (2.06 to 6.35 mm)  
 Grille Depth . . . . . 2 to 6 in. (50.8 to 152.4 mm)  
 Perimeter Frame . . . . . Aluminum Bar, Channel or Tube  
 Horizontal Bar Spacing . . . . . 2 to 12 in. (50.8 to 304.8 mm)  
 Vertical Bar Spacing . . . . . 2 to 12 in. (50.8 to 304.8 mm)  
 Minimum Dimension . . . . . 10 in. (254 mm)  
 Maximum Dimension . . . . . 120 in. (3048 mm)

*One dimension not to exceed 72 in.*

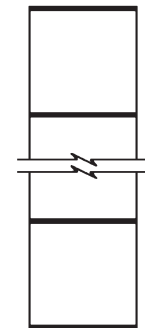

SECTION VIEW



### Options (at additional cost)

- Anchor clips
- A variety of bird and insect screens
- A variety of architectural finishes including:
  - Clear anodize
  - Integral color anodize
  - Baked enamel paint
  - Kynar paint

### Recommended Specifications

#### General

Where indicated on plan drawings or described in schedules, furnish and install Bar Grilles as designed and manufactured by Greenheck Fan Corporation, Schofield, WI. Grilles shall be furnished in the configurations represented on the plan drawings and shall include installation hardware and finishes as specified and required for a complete installation.

#### Welded Assembly

All horizontal, vertical and perimeter frame members shall be joined with slotted or tabbed connections. Where possible, connections shall be secured with fillet welds concealed from view, unless the size of the grille makes bolted connections between grille sections necessary. Each weld shall be manufactured with the Pulsed Gas Metal Arc Welding (GMAW Mig) process. Intermediate connections shall be intermittently joined with a 1 in. (25.4 mm) long fillet weld with a minimum 3/16 in. (4.76 mm) leg. Frames shall be joined at each corner with a full-length GMAW fillet weld with a minimum 3/16 in. (4.76 mm) throat.

#### Products

Architectural grilles shall be Greenheck Bar Grilles as follows:

- Material: Extruded Aluminum, Alloy 6063T5
- Material Thickness: Specify 0.081 in. (2.06 mm) to 0.250 in. (6.35 mm), or as indicated.
- Grille Depth: Specify 2 in. (50.8 mm) to 6 in. (152.4 mm), or as indicated.
- Perimeter Frame: Specify Bar, Channel or Tube, or as indicated.
- Horizontal Bar Spacing: Specify 2 in. (50.8 mm) to 12 in. (304.8 mm), or as indicated.
- Vertical Bar Spacing: Specify 2 in. (50.8 mm) to 12 in. (304.8 mm), or as indicated.

## DETAIL DRAWINGS

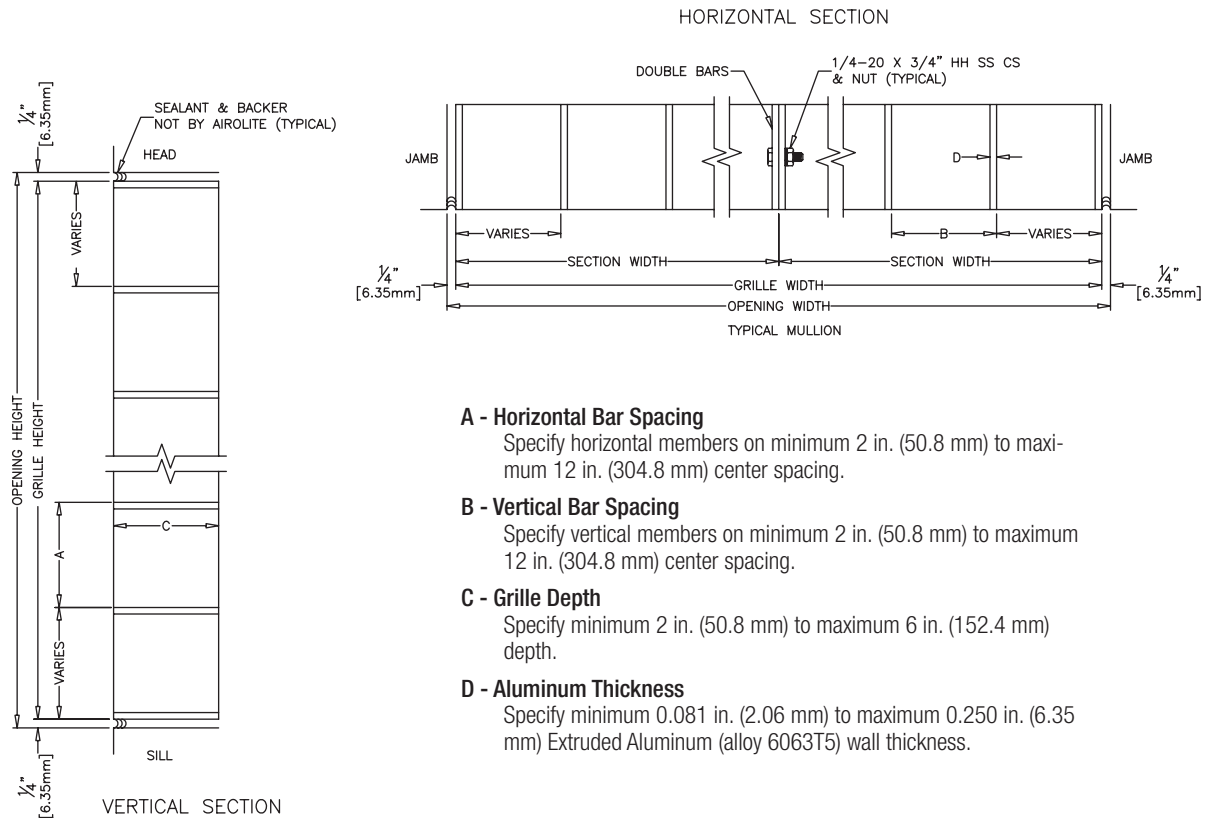

### A - Horizontal Bar Spacing

Specify horizontal members on minimum 2 in. (50.8 mm) to maximum 12 in. (304.8 mm) center spacing.

### B - Vertical Bar Spacing

Specify vertical members on minimum 2 in. (50.8 mm) to maximum 12 in. (304.8 mm) center spacing.

### C - Grille Depth

Specify minimum 2 in. (50.8 mm) to maximum 6 in. (152.4 mm) depth.

### D - Aluminum Thickness

Specify minimum 0.081 in. (2.06 mm) to maximum 0.250 in. (6.35 mm) Extruded Aluminum (alloy 6063T5) wall thickness.

## FINISHES

Finish Type	Description/Application	Color Selection	Standard Warranty (Aluminum)
2-coat 70% KYNAR 500®/HYLAR 5000® AAMA 2605 – Dry film thickness 1.2 mil. (AKA: Duranar®, Fluoropon®, Trinar®, Flouropolymer, Polyvinylidene Fluoride, PVDF2)	<b>“Best.”</b> The premier finish for extruded aluminum. Tough, long-lasting coating has superior color retention and abrasive properties. Resists chalking, fading, chemical abrasion and weathering.	<b>Standard Colors:</b> Any of the 24 standard colors shown can be furnished in 70% or 50% KYNAR 500®/HYLAR 5000® or Baked Enamel.  <b>2-Coat Mica:</b> Greenheck offers 9 standard 2-coat Mica colors. Other colors are available. Consult Greenheck for possible extra cost when selecting non-standard colors or special finishes.	10 Years (Consult Greenheck for availability of extended warranty)
2-coat 50% KYNAR 500®/HYLAR 5000® AAMA 2604 – Dry film thickness 1.2 mil. (AKA: Acroflur®, Acrynar®)	<b>“Better.”</b> Tough, long-lasting coating has excellent color retention and abrasive properties. Resists chalking, fading, chemical abrasion and weathering.		5 Years
Baked Enamel AAMA 2603 – Dry film thickness 0.8 mil. (AKA: Acrabond Plus®, Duracron®)	<b>“Good.”</b> Provides good adhesion and resistance to weathering, corrosion and chemical stain.		1 Year
Integral Color Anodize AA-M10C22A42 (>0.7 mil)	“Two-step” anodizing is produced by following the normal anodizing step with a second, colorfast process.	Light, Medium or Dark Bronze; Champagne; Black	5 years
Clear Anodize 215 R-1 AA-M10C22A41 (>0.7 mil)	Clear, colorless and hard oxide aluminum coating that resists weathering and chemical attack.	Clear	5 years
Clear Anodize 204 R-1 AA-M10C22A31 (0.4-0.7 mil)	Clear, colorless and hard oxide aluminum coating that resists weathering and chemical attack.	Clear	1 Year
Industrial coatings	Greenheck offers a number of industrial coatings such as Hi-Pro Polyester, Epoxy, and Permatector®. Consult a Greenheck Product Specialist for complete color and application information.		Consult Greenheck
Mill	Materials may be supplied in natural aluminum or galvanized steel finish when normal weathering is acceptable and there is no concern for color or color change.		n/a

Finishes meet or exceed AAMA 2605, AAMA 2604, and AAMA 2603 requirements. Please consult [www.greenheck.com](http://www.greenheck.com) for complete information on standard and extended paint warranties. Paint finish warranties are not applicable to steel products.



Bar Grille March 2007  
Copyright © 2007 Greenheck Fan Corporation

Greenheck Fan Corporation reserves the right to make product changes without notice.