

Cast Aluminum Brick Vent

Application and Design

Brick vents provide a permanent means of ventilation for crawl spaces, hung ceilings, incinerator rooms, chimney flues, foundations, pipe spaces and corridors. Cast aluminum construction, made from high corrosion resistant alloy #319, provides rugged load bearing capabilities. A water stop, deep overlapping blades and drips at the top and bottom of the casting, provide maximum resistance to rain and weather.

Standard Construction

- Frame** Heavy gauge cast aluminum,
4 in. x 0.125 in. nominal wall thickness
- Blades** Heavy gauge cast aluminum,
0.125 in. nominal wall thickness
- Insect screen** .. 7 in. x 7 in. aluminum mesh, inside mount (rear)
- Finish** Mill
- Available Sizes** . 8 in. W x 2 1/4 in. H
8 1/4 in. W x 4 15/16 in. H
8 in. W x 7 7/8 in. H
12 in. W x 2 3/4 in. H
12 in. W x 3 1/2 in. H
12 in. W x 5 in. H
12 in. W x 7 3/4 in. H
16 1/2 in. W x 2 3/8 in. H
16 in. W x 4 15/16 in. H
16 in. W x 6 in. H
16 in. W x 7 3/4 in. H

Options (at additional cost)

- Single blade flap damper
- Straight duct
(0.063 in aluminum for up to 18 in. wall thickness)
- A variety of architectural finishes including:
Baked enamel paint
Kynar paint

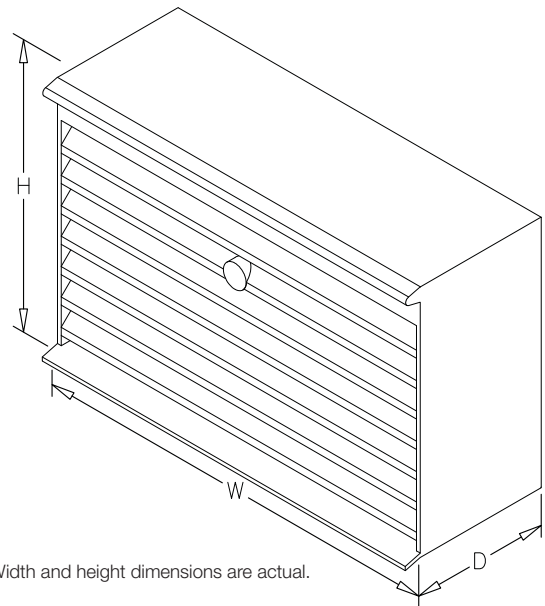
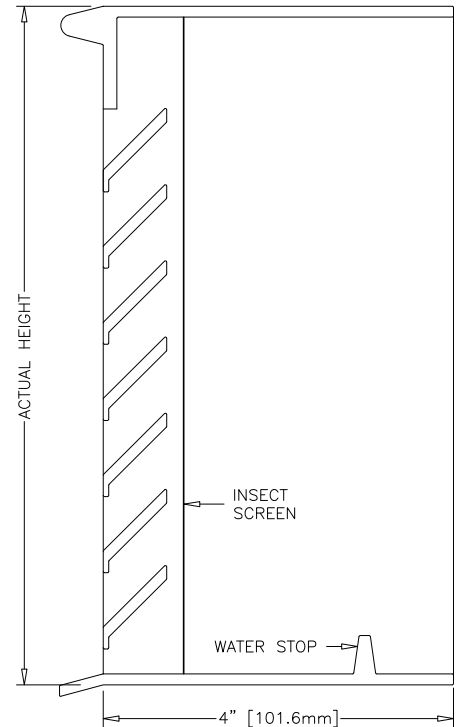

*Width and height dimensions are actual.

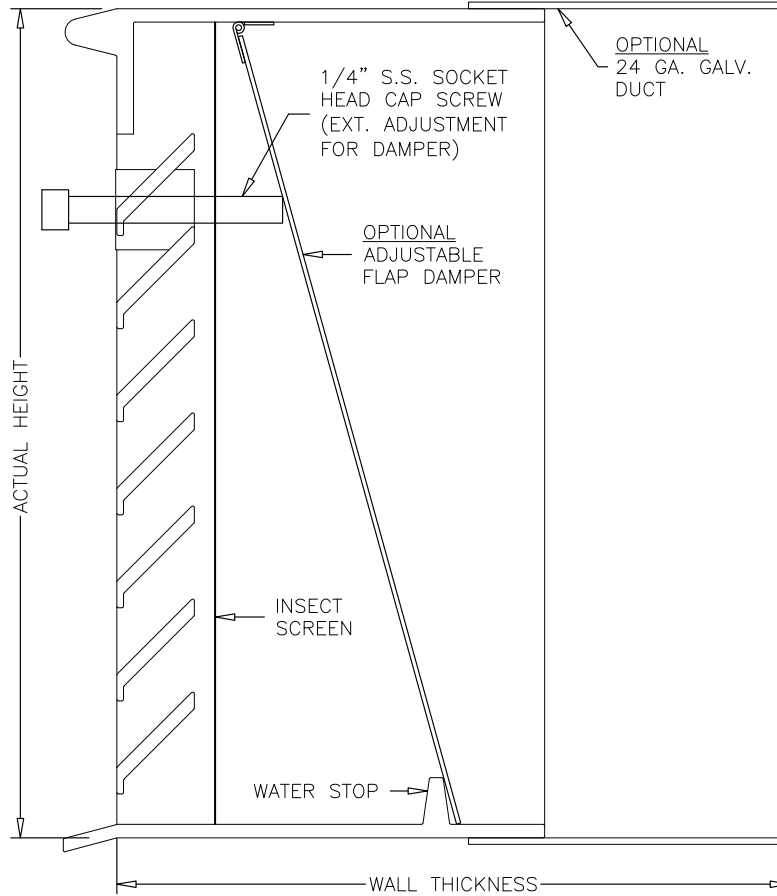

FINISHES

Finish Type	Description/Application	Color Selection	Standard Warranty (Aluminum)
2-coat 70% KYNAR 500®/HYLAR 5000® AAMA 2605 – Dry film thickness 1.2 mil. (AKA: Duranar®, Fluoropon®, Trinar®, Fluoropolymer, Polyvinylidene Fluoride, PVDF2)	“Best.” The premier finish for extruded aluminum. Tough, long-lasting coating has superior color retention and abrasive properties. Resists chalking, fading, chemical abrasion and weathering.	Standard Colors: Any of the 24 standard colors shown can be furnished in 70% or 50% KYNAR 500®/HYLAR 5000® or Baked Enamel. 2-Coat Mica: Greenheck offers 9 standard 2-coat Mica colors. Other colors are available. Consult Greenheck for possible extra cost when selecting non-standard colors or special finishes.	10 Years (Consult Greenheck for availability of extended warranty)
2-coat 50% KYNAR 500®/HYLAR 5000® AAMA 2604 – Dry film thickness 1.2 mil. (AKA: Acroflur®, Acrynar®)	“Better.” Tough, long-lasting coating has excellent color retention and abrasive properties. Resists chalking, fading, chemical abrasion and weathering.		5 Years
Baked Enamel AAMA 2603 – Dry film thickness 0.8 mil. (AKA: Acrabond Plus®, Duracron®)	“Good.” Provides good adhesion and resistance to weathering, corrosion and chemical stain.		1 Year
Integral Color Anodize AA-M10C22A42 (>0.7 mil)	“Two-step” anodizing is produced by following the normal anodizing step with a second, colorfast process.	Medium or Dark Bronze	5 years
Clear Anodize 204 R-1 AA-M10C22A31 (0.4-0.7 mil)	Clear, colorless and hard oxide aluminum coating that resists weathering and chemical attack.	Clear	1 Year
Industrial coatings	Greenheck offers a number of industrial coatings such as Hi-Pro Polyester, Epoxy, and Permatector®. Consult a Greenheck Product Specialist for complete color and application information.		Consult Greenheck
Mill	Materials may be supplied in natural aluminum or galvanized steel finish when normal weathering is acceptable and there is no concern for color or color change.		n/a

Finishes meet or exceed AAMA 2605, AAMA 2604, and AAMA 2603 requirements. Please consult www.greenheck.com for complete information on standard and extended paint warranties. Paint finish warranties are not applicable to steel products.

