

VALV-POWR® SERIES VPVL MODEL C DOUBLE-ACTING AND SPRING-RETURN RACK- AND-PINION COMPACT PNEUMATIC ACTUATORS

VALV-POWR – VPVL double-opposed piston actuators combine the benefits of high cycle life, a rugged construction, and an extremely compact and symmetrical design with a unique range of features and options. They are specifically designed for fast efficient operation of ball, butterfly, and other rotary type valves.

FEATURES

Single-Source Responsibility

- Valves, actuators, and accessories are designed to operate as a unit with the highest degree of compatibility.
- Valves, actuators, and accessories can be supplied completely assembled to provide unit responsibility from a single source.

Versatility

- Modular designs with same body and end caps for double-acting and spring-return reduce inventory. Springs can be added in the field to convert double-acting to spring-return or for changes in supply pressure.
- Failure direction can be easily reversed from spring-to-open or spring-to-close orientation simply by inverting the pistons.
- Actuator to valve attachments comply with ISO 5211/1 and EN 12116.
- Solenoid valve and accessory attachments comply with NAMUR VDI/VDE 3845.
- A wide range of optional accessories and control devices that include limit switches, solenoid valves, and mechanical safety lockouts are available to satisfy virtually all automated valve requirements.
- Several models of 180 degree VPVL's are optionally available.

High Cycle Life

- Bearings on all sliding and rotating moving parts to ensure long life.
- Dual piston rack-and-pinion mechanism for simple construction, high cycle life, and constant torque.
- Hard-anodized PTFE-coated extruded aluminum body with honed internal surface for strength and lower coefficient of friction.
- Mechanically multi-guided aluminum pistons for precise movement, low friction, and high cycle life.



- Machined teeth on piston racks and pinions for excellent rack and pinion engagement and maximum efficiency.

Corrosion Resistant

- Hard-anodized PTFE-coated body, polyester-coated end caps, and epoxy-coated springs, along with internal and external stainless steel fasteners, provide corrosion resistance in a variety of difficult applications and environments.

Reliability

- Safety-contained multi-spring design with preloaded and heavy-duty coated springs for simpler range versatility, greater safety, and corrosion resistance.
- External adjustable stops in both directions assure flexibility and accuracy when setting the valve in the open and closed positions.
- As an added safety feature, the external adjustment screws are slotted. The slot will indicate the presence of internal pressure. Pressure will begin to vent before the adjustment screws are completely backed out of the actuator.

SPECIFICATIONS

Maximum Supply Range: 116 psi (8 bar)

Temperature Range:

Standard -4°F to +175°F (-20°C to +80°C)

Optional -40°F to +300°F (-40°C to +150°C)

Rotation Adjustment: -4° to +4°; 86° to 94°

Supply Media: Air, mineral-based hydraulic fluid

STANDARDS

Actuator to valve mounting: EN12116 ISO 5211/1

Actuator to solenoid mounting: Namur, VDI/VDE3845**

Actuator to accessory mounting: Namur, VDI/VDE3845*

* Except VPVL011

** Except VPVL011, 650, 700, 800

ACTUATOR SELECTION

To select an actuator for a particular valve and service, first determine the maximum operating torque that will be required from the applicable valve bulletin. Then refer to the appropriate torque output table and select an actuator that will, at the available supply pressure, provide a torque output no less than the required operating torque for the

valve. For spring-return units, both the spring torque and the air torque must be sufficient. In the event confirmation is desired for the selection of an actuator under specific service conditions, include full details on trim, seat materials, and media characteristics.

Actuator Model		Air Volume						Bore Diam.		Moving Time Seconds ¹		Weight	
		in. ³			ml								
		Opening	Closing	Swept	Opening	Closing	Swept	in.	mm	Opening	Closing	lb.	kg
VPVL011	DA	3.1	4	1.2	50.8	65.6	20.3	1.5	38	0.2	0.2	1.0	0.5
VPVL051	DA	5.5	9.2	3.4	90.1	150.8	55.5	1.97	50	0.2	0.3	2.1	1.0
	SR		–			–				0.3	0.3	2.3	1.1
VPVL100	DA	9.8	15.9	6.0	160.6	260.6	97.8	2.48	63	0.3	0.3	3.3	1.5
	SR		–			–				0.3	0.4	3.8	1.7
VPVL200	DA	18.9	29.9	11.8	309.7	490	194.1	2.95	75	0.3	0.4	5.9	2.7
	SR		–			–				0.4	0.5	7.0	3.2
VPVL250	DA	31.1	47.6	18.6	509.6	780	305.4	3.46	88	0.4	0.5	8.4	3.8
	SR		–			–				0.5	0.6	9.7	4.4
VPVL300	DA	43.3	67.7	27.1	709.6	1109	443.7	3.94	100	0.5	0.6	11.9	5.4
	SR		–			–				0.7	0.9	14.3	6.5
VPVL350	DA	72.6	109.8	43.8	1190	1799	717.2	4.53	115	0.7	0.8	18.6	8.4
	SR		–			–				0.9	1.1	21.7	9.8
VPVL400	DA	94	143	56	1540	2443	924	4.92	125	0.9	1.1	22.5	10.2
	SR		–			–				1.2	1.4	27.8	12.6
VPVL450	DA	147	231	89	2409	3765	1451	5.71	145	1.2	1.4	32.0	14.5
	SR		–			–				1.5	1.8	39.9	18.1
VPVL500	DA	192	300	116	3146	4916	1893	6.30	160	1.5	1.7	43.7	19.8
	SR		–			–				1.8	2.1	52.9	24.0
VPVL550	DA	260	420	156	4261	6883	2556	7.09	180	2.0	2.2	55.1	25.0
	SR		–			–				2.4	2.8	69.7	31.6
VPVL600	DA	362	577	217	5932	9455	3549	7.87	200	2.7	3.2	78.3	35.5
	SR		–			–				3.5	4.0	99.4	45.1
VPVL650	DA	610	928	364	10000	15200	5963	9.45	240	3.5	4.0	115	53
	SR		–			–				4.1	4.6	139	64
VPVL700	DA	885	1305	528	14503	21385	8655	10.43	265	4.0	4.5	183	83
	SR		–			–				4.5	5.0	225	102
VPVL800	DA	1526	2441	917	25000	40000	15032	12.99	330	6.0	7.0	295	134
	SR		–			–				7.5	8.5	373	169

NOTES:
 (1) The above times are based on the following conditions: A) Room temperature , B) Solenoid valve orifice diameter of 4 mm (5/32 in.) and a flow rate capacity of 400 L/min (14.1 cfm), C) Minimum inner piping diameter of 8 mm (5/16 in.), D) 5.5 bar (80 psi) air supply pressure, E) Without valve loading.

ACTUATOR SELECTION (CONTINUED) SPRING RETURN

Actuator Model	Spring-Return Torque Output		Air Torque Output at Specified Supply Pressure			
	FT•LBS	N•m	FT•LBS _s @ 60 psi	N•m @ 4.2 bar	FT•LBS @ 80 psi	N•m @ 5.5 bar
051 SR4/5	4.5	6.1	3.7	4.9		
051 SR6	6	8.1			4.9	6.6
100 SR4/5	7.4	10	6.7	8.5		
100 SR6	9.8	13.3			8.9	12
200 SR4/5	14.7	19.9	12	17		
200 SR6	19.6	26.5			16	22
250 SR4/5	24.3	33	17	24		
250 SR6	32.5	44.5			23	32
300 SR4/5	33.6	45.6	28	40		
300 SR6	44.9	60.8			38	51
350 SR4/5	54.4	73.8	44	62		
350 SR6	72.6	98.4			58	79
400 SR4/5	69.7	95	59	84		
400 SR6	93	126			79	107
450 SR4/5	109	148	94	133		
450 SR6	146	198			126	169
500 SR4/5	149	202	126	178		
500 SR6	199	269			168	225
550 SR4/5	210	285	153	278		
550 SR6	280	379			204	274
600 SR4/5	282	383	231	327		
600 SR6	376	510			308	414
650 SR4/5	479	649	399	541		
650 SR6	638	865			532	721
700 SR4/5	724	981	520	737		
700 SR6	966	1308			693	931
800 SR4/5	1221	1656	1105	1498		
800 SR6	1628	2207			1473	1997

DOUBLE ACTING

Actuator Model	Torque Output in FT•LBS - VPVL XXDA Double-Acting Actuator at Specified psi Supply Pressures						
	40 psi	50 psi	60 psi	70 psi	80 psi	90 psi	100 psi
VPVL 011 DA	2.5	3.1	3.7	4.3	4.9	5.5	6.2
051	6.8	8.5	10.1	11.8	13.5	15.2	16.9
100	12	14.9	17.9	20.9	23.9	26.8	29.8
200	23.7	29.6	35	41	47	53	59
250	37.2	46.6	55	65	74	83	93
300	54	67.6	81	94	108	122	135
350	87.5	109	131	153	175	197	219
400	113	141	169	197	225	254	282
450	177	221	265	310	354	398	442
500	231	289	346	404	462	519	577
550	312	390	467	545	623	701	779
600	433	541	649	757	866	974	1082
650	727	909	1091	1272	1454	1636	1818
700	1055	1319	1583	1847	2111	2375	2638
800	1833	2291	2749	3207	3665	4123	4581

Actuator Model	Torque Output in N•m - VPVL XXDA Double-Acting Actuator at Specified bar Supply Pressures						
	2.7 bar	3.5 bar	4.2 bar	4.8 bar	5.5 bar	6.2 bar	6.9 bar
VPVL 011 DA	3.2	4.2	5.1	5.8	6.7	7.6	8.5
051	8.9	11.6	14	16	18.3	20.7	23
100	16	20.5	24.6	28.1	32	36	40
200	31	40	48	55	64	72	80
250	48	66	79	90	103	117	130
300	68	93	112	128	146	165	184
350	115	150	181	207	236	266	296
400	143	194	233	266	305	344	383
450	224	304	365	417	478	539	600
500	293	397	477	545	624	703	782
550	395	536	643	735	842	949	1056
600	575	745	893	1021	1170	1319	1468
650	986	1232	1479	1725	1971	2218	2465
700	1338	1815	2179	2490	2853	3216	3579
800	2485	3106	3727	4348	4969	5590	6211

OPTIONS

Solenoid Valves

Direct-mounted solenoid valves are available in both 3-way and 4-way configuration, which mount directly to the actuator in accordance with NAMUR and VDI/VDE 3845 standards, excluding the VPVL011, 650, 700 and 800. In general, 3-way solenoids are used for spring-return actuators and 4-way versions for double-acting.

Direct-Mount Solenoid Valves		
Part Number	031-0576-01	031-0580-01
Enclosure	NEMA IV	NEMA VII
Configuration	3 or 4-way	
Pipe Size	1/4" Inlet, 1/8" Exhaust	
Cv	0.7	
Voltage	Standard: 120 VAC 60 Hz (110/50) Optional: 240 VAC 60 Hz, 12 VDC, 24 VDC	
Body Material	Black Anodized Aluminum	
Power Consumption	AC: 6.9 watts DC: 6.3 watts	

NOTE: Please consult factory for other solenoid valves or additional options including special voltages, double solenoids, special electrical connections, etc.

Mechanical Safety Lockout

To comply with the intent of OSHA requirements for locking actuators in position prior to performing maintenance, an actuator can have the mechanical safety lockout option added to it. Design of the stop cam allows for locking the actuator in either the full-open or full-closed position. Actuators equipped with this option have a special lockout screw and a tamperproof cover attached to the housing of the actuator with stainless steel wire. The lockout kits are readily available to permanently lock the actuator in place to prevent unwanted operation.

100% Adjustable Travel Stop

To limit the rotation on the stroke beyond the standard $\pm 4^\circ$ of a VPVL actuator, a stainless steel 100%-adjustable travel stop option can be added. The stops, located in the

end caps, allow the valve position to be set anywhere between full closed and full open. This option limits travel of only the counter-clockwise stroke for standard double-acting and spring-closed units. The 100% Adjustable Stop option is specified in the actuator ordering code.

Actuator	100% Travel Stop Lengths			
	L Min		L Max	
	inch	mm	inch	mm
VPVL051	6.2	158	7.3	186
VPVL100	7.2	184	8.5	216
VPVL200	9.5	242	11.3	286
VPVL250	11.0	280	13.0	330
VPVL300	11.9	303	14.1	359
VPVL350	14.0	356	16.7	424
VPVL400	14.5	368	17.5	444
VPVL450	17.7	449	21.1	537
VPVL500	18.1	461	21.9	555
VPVL550	20.9	531	24.8	631
VPVL600	24.7	628	29.1	739
VPVL650	25.7	653	30.9	785
VPVL700	30.0	762	36.1	918
VPVL800	35.8	910	42.8	1086

Lockout Kits	
VPVL051	LD78
VPVL100	LD79
VPVL200	LD80
VPVL250	LD81
VPVL300	LD82
VPVL350	LD83
VPVL400	LD84
VPVL450	LD85
VPVL500	LD86
VPVL550	LD87
VPVL600	LD88
VPVL650	LD89
VPVL700	LD90
VPVL800	LD91

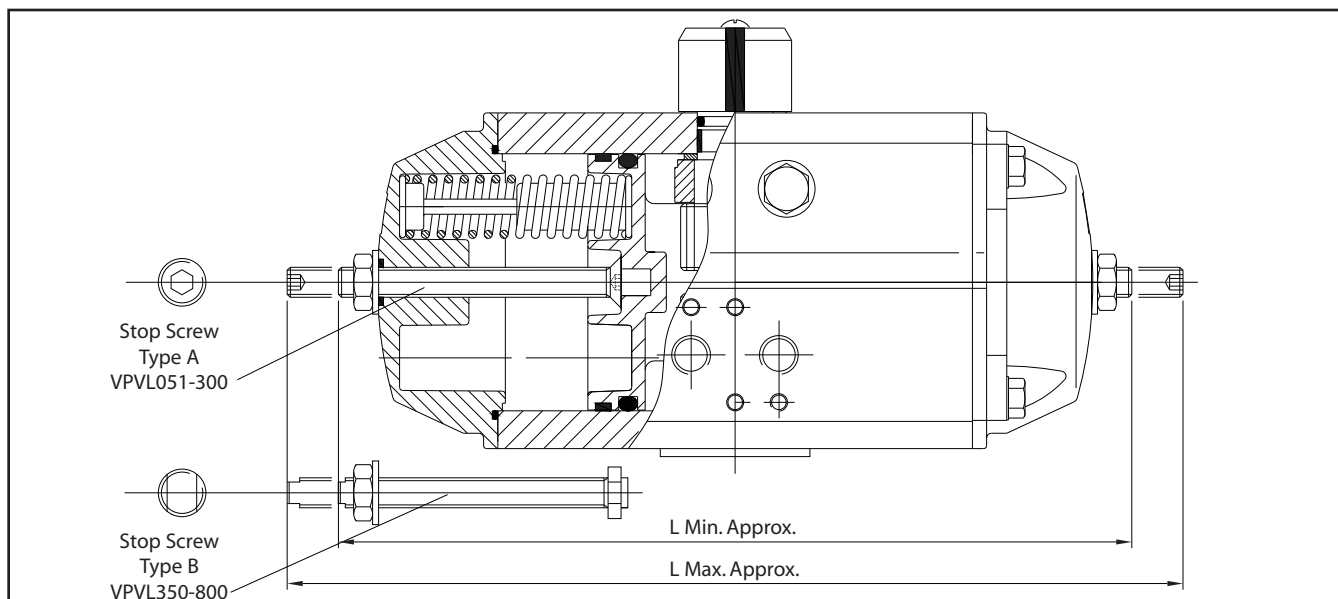
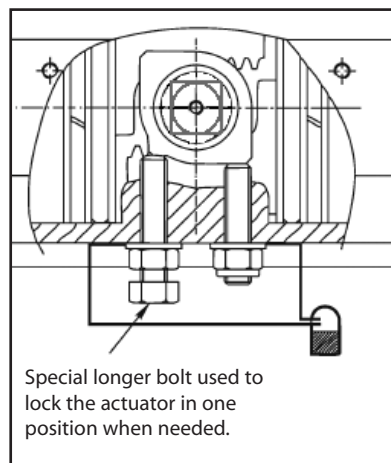

Declutchable Manual Override

A side-declutchable manual override is available for VPVL actuators. It consists of a manual gear actuator mounted between the actuator and the valve. The device is normally disengaged from the shaft. Upon engagement of the override clutch, overriding the actuator is done with ease, aided by the high-reduction ratio of the manual gear unit.

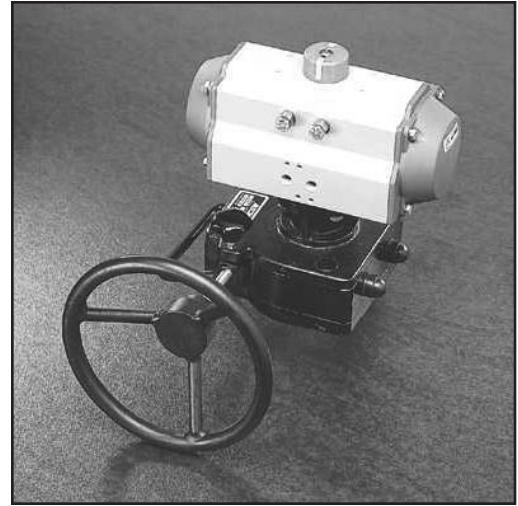

DIMENSIONS

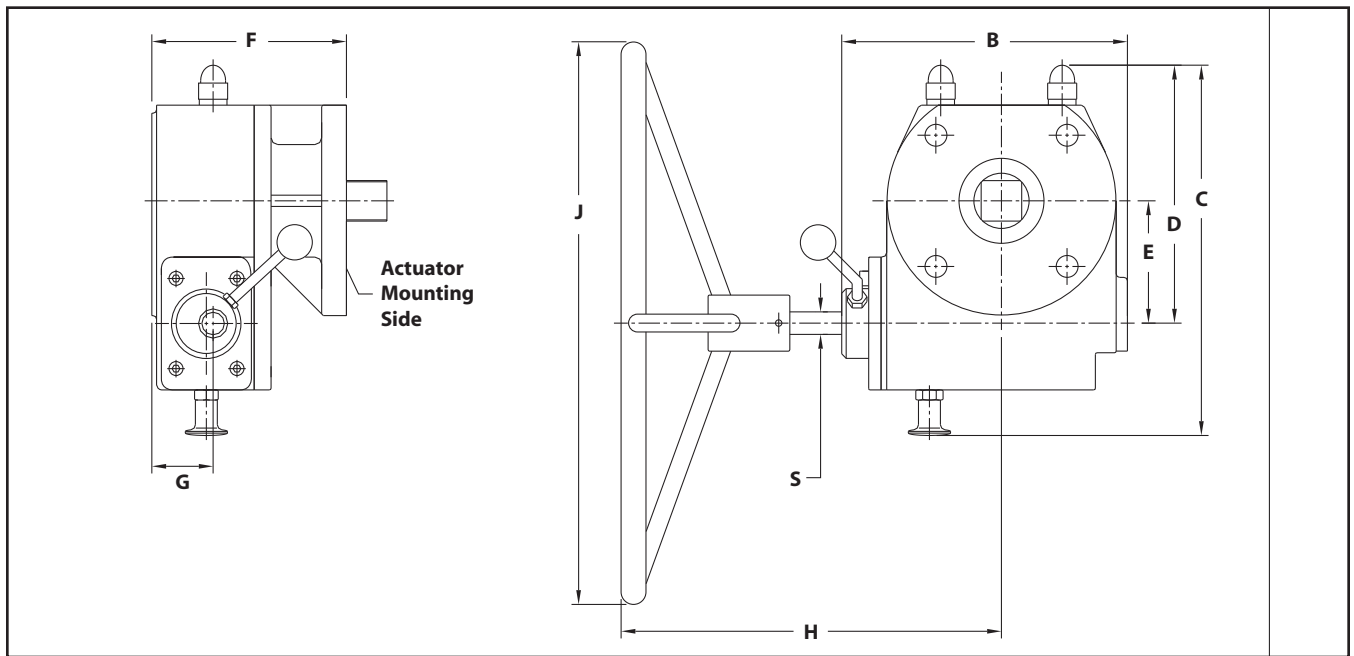

VPVL Actuator Model (DA or SR)	Declutchable Override Kit	Approximate Dimensions - Inches									Approx. Weight lbs.
		B	C	D	E	F	G	H	J	S	
VPVL250 and VPVL300	DO-1	5.75	6.89	5.61	2.36	4.53	1.44	8.94	7.87	0.47	22
VPVL350 and VPVL400	DO-2	7.68	9.49	6.06	2.48	5.63	2.09	10.28	7.87	0.59	40
VPVL450 and VPVL500	DO-3	8.74	11.12	7.46	3.31	6.30	2.48	10.63	11.81	0.79	50
VPVL550 and VPVL600	DO-4	9.84	12.84	9.00	4.23	6.77	2.36	13.31	19.69	0.79	84
VPVL650 and VPVL700*	DO-5	10.87	14.45	10.16	5.00	7.48	2.68	14.41	35.43	0.98	141
VPVL800	DO-6	13.39	16.69	12.32	6.06	8.07	3.07	15.63	39.37	0.98	201

* The VPVL700 DA unit may be used if the air pressure required to produce the needed output torque is lower than 95 psi.

VPVL Actuator Model (DA or SR)	Declutchable Override Kit	Approximate Dimensions - mm									Approx. Weight kgs.
		B	C	D	E	F	G	H	J	S	
VPVL250 and VPVL300	DO-1	146	175	142	60	115	37	227	200	12	10
VPVL350 and VPVL400	DO-2	195	241	154	63	143	53	261	200	15	18
VPVL450 and VPVL500	DO-3	222	282	190	84	160	63	270	300	20	23
VPVL550 and VPVL600	DO-4	250	326	228	107	172	60	338	500	20	38
VPVL650 and VPVL700*	DO-5	276	367	258	127	190	68	366	900	25	64
VPVL800	DO-6	340	424	313	154	205	78	397	1000	25	91

* The VPVL700 DA unit may be used if the air pressure required to produce the needed output torque is lower than 6.5 bar.

DIMENSIONS

Model VPVL 051 - 800

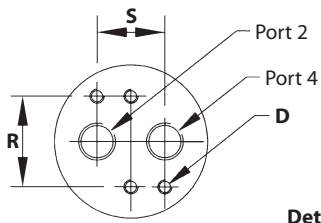
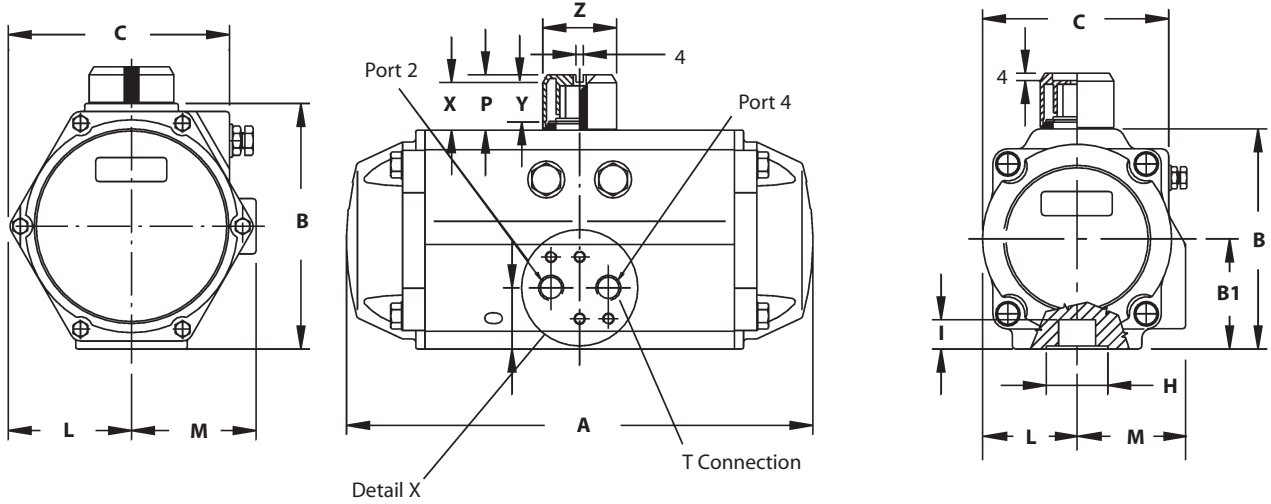

VPVL 051 - 600

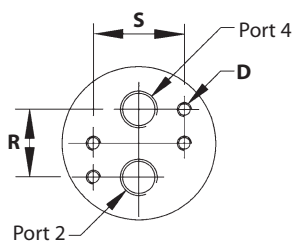

VPVL 011, 650 - 800

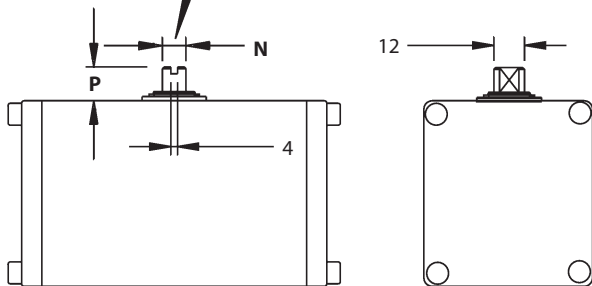
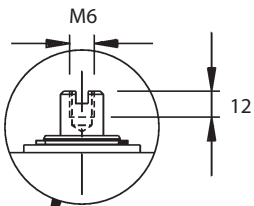
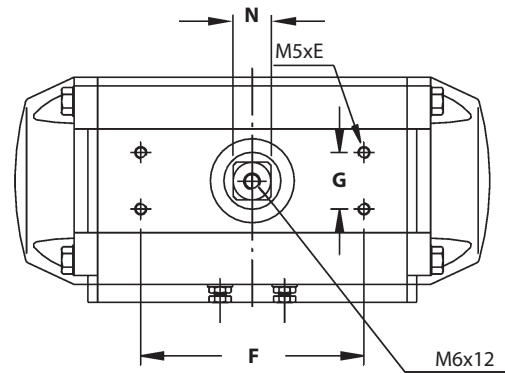

Model VPVL011

BottomView ISO5211

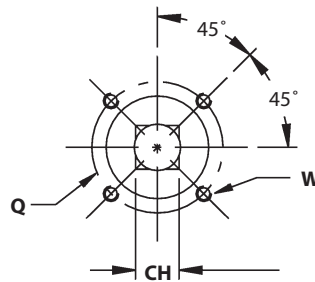

Dimensions- inches / lb.

Size	Dimensions- inches / lb.																Weight										
	A	B	B1	C	D	E	F	G	H	I	L	M	N	O	P	Q	R	S	W	X	Y	T NPT	ISO Flange	CH	Z	DA	SR
011	4.50	1.70	0.00	1.70	M5x4	0.28	1.97	0.98	0.79	0.39	0.80	0.80	0.43	-	0.79	1.40	0.94	1.26	M5	0.57	0.32	1/8	F03	0.35	1.57	1.0	-
051	5.53	2.72	1.36	2.32	M5x8	0.16	3.15	1.18	0.98	0.47	1.14	1.63	0.43	1.04	0.79	1.40	1.26	0.94	M5	0.57	0.31	1/8	F03	0.43	1.57	2.1	2.3
100	6.24	3.35	1.67	2.83	M5x8	0.31	3.15	1.18	1.38	0.63	1.42	1.85	0.43	1.18	0.79	1.97	1.26	0.94	M6	0.57	0.31	1/8	F05	0.55	1.57	3.3	3.8
200	8.29	4.02	2.01	3.33	M5x8	0.31	3.15	1.18	1.38	0.63	1.67	2.05	0.67	1.20	0.79	1.97	1.26	0.94	M6	0.57	0.31	1/8	F05	0.55	1.57	5.9	7.0
250	9.74	4.53	2.26	3.84	M5x8	0.31	3.15	1.18	2.17	0.83	1.95	2.24	0.67	1.28	0.79	2.76	1.26	0.94	M8	0.57	0.31	1/8	F07	0.75	1.57	8.4	9.7
300	10.57	5.00	2.50	4.37	M5x8	0.31	3.15	1.18	2.17	0.83	2.20	2.64	0.67	1.48	0.79	2.76	1.26	0.94	M8	0.57	0.31	1/4	F07	0.75	1.57	11.9	14.3
350	12.40	5.71	2.85	5.00	M5x8	0.31	3.15	1.18	2.76	0.94	2.52	3.03	1.06	1.67	1.18	4.02	1.26	0.94	M10	0.96	0.57	1/4	F10	0.87	2.20	18.5	21.7
400	13.58	6.18	3.09	5.35	M5x8	0.31	3.15	1.18	2.76	0.94	2.74	3.23	1.06	1.77	1.18	4.02	1.26	0.94	M10	0.96	0.57	1/4	F10	0.87	2.20	22.5	27.8
450	16.08	6.97	3.88	6.16	M5x8	0.31	3.15	1.18	3.35	1.38	3.15	3.60	1.06	1.85	1.18	4.92	1.26	0.94	M12	0.96	0.57	1/4	F12	1.06	2.56	32	40
500	17.22	7.72	3.86	6.65	M5x8	0.31	3.15	1.18	3.35	1.38	3.46	3.90	1.06	2.05	1.18	4.92	1.26	0.94	M12	0.96	0.57	1/4	F12	1.06	2.56	44	53
550	19.17	8.68	4.39	7.51	M5x8	0.31	5.12	1.18	3.94	1.57	3.90	4.13	1.42	2.28	1.97	5.51	1.26	0.94	M16	1.75	0.79	1/4	F14	1.42	3.15	55	70
600	21.38	9.65	4.80	8.39	M5x8	0.31	5.12	1.18	3.94	1.57	4.33	4.41	1.42	2.44	1.97	5.51	1.26	0.94	M16	1.75	0.79	1/4	F14	1.42	3.15	78	99
650	24.45	11.75	5.93	9.88	M6x10	0.31	5.12	1.18	5.12	1.89	5.16	5.16	1.42	3.09	1.97	6.50	1.57	1.77	M20	1.75	0.79	3/8	F16	1.81	4.53	115	139
700	26.93	12.99	6.50	11.75	M6x10	0.31	5.12	1.18	5.12	1.97	6.44	6.54	1.42	6.50	1.97	6.50	1.57	1.77	M20	1.75	0.79	1/2	F16	1.81	4.53	183	225
800	34.39	16.14	6.50	15.08	M6x10	0.31	5.12	1.18	7.87	2.24	8.03	8.43	1.42	7.28	1.97	10.00	1.57	1.77	M16	1.75	0.79	1/2	F25	2.17	4.53	295	373

Dimensions- mm / kg

Size	Dimensions- mm / kg																Weight										
	A	B	B1	C	D	E	F	G	H	I	L	M	N	O	P	Q	R	S	W	X	Y	T NPT	ISO Flange	CH	Z	DA	SR
011	114	43	0.0	43	M5x4	7	50	25	20	10	20	20	11	-	20	36	24	32	M5	14.5	8.0	1/8	F03	9	40	0.45	-
051	140	69	34.5	59	M5x8	4	80	30	25	12	29	41	11	26	20	36	32	24	M5	14.5	8.0	1/8	F03	11	40	0.95	1.04
100	158	85	42.5	72	M5x8	8	80	30	35	16	36	47	11	30	20	50	32	24	M6	14.5	8.0	1/8	F05	14	40	1.5	1.7
200	211	102	51.0	85	M5x8	8	80	30	35	16	42	52	17	30	20	50	32	24	M6	14.5	8.0	1/8	F05	14	40	2.7	3.2
250	247	115	57.5	98	M5x8	8	80	30	55	21	50	57	17	33	20	70	32	24	M8	14.5	8.0	1/8	F07	19	40	3.8	4.4
300	268	127	63.5	111	M5x8	8	80	30	55	21	56	67	17	38	20	70	32	24	M8	14.5	8.0	1/4	F07	19	40	5.4	6.5
350	315	145	72.5	127	M5x8	8	80	30	70	24	64	77	27	42	30	102	32	24	M10	24.5	14.5	1/4	F10	22	56	8.4	9.8
400	345	157	78.5	136	M5x8	9	80	30	70	24	70	82	27	45	30	102	32	24	M10	24.5	14.5	1/4	F10	22	56	10	13
450	408	177	98.5	156	M5x8	8	80	30	85	35	80	91	27	47	30	125	32	24	M12	24.5	14.5	1/4	F12	27	65	15	18
500	437	196	98.0	169	M5x8	8	80	30	85	35	88	99	27	52	30	125	32	24	M12	24.5	14.5	1/4	F12	27	65	20	24
550	487	220	111.5	191	M5x8	8	130	30	100	40	99	105	36	58	50	140	32	24	M16	44.5	20.0	1/4	F14	36	80	25	32
600	543	245	122.0	213	M5x8	8	130	30	100	40	110	112	36	62	50	140	32	24	M16	44.5	20.0	1/4	F14	36	80	35	45
650	621	298	150.5	251	M6x10	8	130	30	130	48	131	131	36	78	50	165	40	45	M20	44.5	20.0	3/8	F16	46	115	53	64
700	684	330	165.0	298	M6x10	8	130	30	130	50	164	166	36	165	50	165	40	45	M20	44.5	20.0	1/2	F16	46	115	83	102
800	876	410	165.0	383	M6x10	8	130	30	200	57	204	214	36	185	50	254	40	45	M16	44.5	20.0	1/2	F25	55	115	134	169

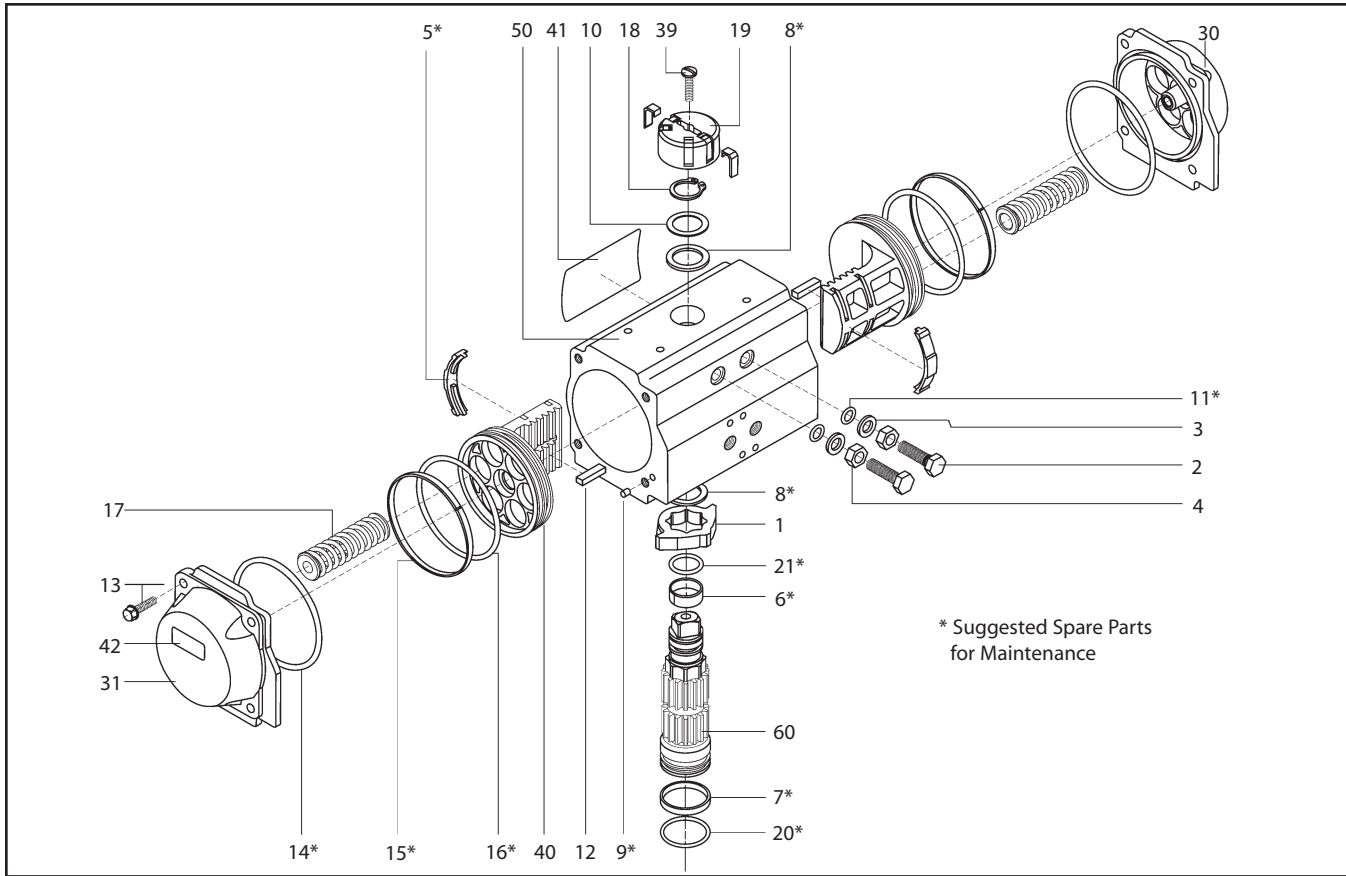

BILL OF MATERIALS AND PARTS LIST

No.	Unit Qty	Part Description	Material	Specifications	Corrosion Protection
1	1	Octi-Cam (Stop Arrangement)	Stainless Steel ¹	EN 10088-3/ISO 1083 ¹	
2	2	Stop Cap Screw	Stainless Steel	ASTM A193	
3	2	Washer (Stop Cap Screw)	Stainless Steel	ISO 3506	
4	2	Nut (Stop Cap Screw)	Stainless Steel	ISO 3506	
5*	2	Bearing (Piston Back)	Polyphthalamide	Amodel ET1001HS	
6*	1	Bearing (Pinion Top)	Polyetherimide	Stanyl TW300	
7*	1	Bearing (Pinion Bottom)	Polyetherimide	Stanyl TW300	
8*	2	Thrust Bearing (Pinion)	Polyphthalamide	Amodel ET1001HS	
9*	2	Plug (Transfer Port)	Nitrile Rubber	NBR 70Shore A	
10	1	Thrust Washer (Pinion)	Stainless Steel	EN 10088-3	
11*	2	O-ring (Stop Cap Screw Seal)	Nitrile Rubber	NBR 70Shore A	
12	2	Piston Guide	Polyphthalamide GF	Amodel AS1145	
13	8/12/ ²	Cap Screw (End Cap)	Stainless Steel	ISO 3506	
14*	2	O-ring (End Cap)	Nitrile Rubber	NBR 70Shore A	
15*	2	Bearing (Piston Head)	Polyphthalamide	Amodel ET1001HS	
16*	2	O-ring (Piston)	Nitrile Rubber	NBR 70Shore A	
17	min. 4/ max.12	Spring (Cartridge)	Alloy Steel	DIN 17223 Part2	Epoxy Coated
18	1	Spring Clip (Pinion)	Carbon Steel	DIN 17222	ENP
19	1	Position Indicator	Polypropylene GF	Hostalen PPN	
20*	1	O-ring (Pinion Bottom)	Nitrile Rubber	NBR 70Shore A	
21*	1	O-ring (Pinion Top)	Nitrile Rubber	NBR 70Shore A	
30	1 ³	Right End Cap ³	Aluminum	UNI 5075	Polyester-Coated
31	1 ³	Left End Cap ³	Aluminum	UNI 5075	Polyester-Coated
39	1	Cap Screw (Indicator)	Stainless Steel	ISO 3506	
40	2	Pistons	Aluminum	UNI 5075	Anodized
41	1	Actuator Identification Label	Polyester Aluminum		
42	2	End Cap Label	Polyester Aluminum		
50	1	Body	Aluminum	ASTM B221	Anodized PTFE-Coated
60	1	Drive Shaft	Carbon Steel Plated	ASTM A105	ENP

* Suggested spare parts for maintenance

Notes: (1) AISI 420 for models VPVL-051 through 300; GS400-15 for models VPVL-350 through 800

(2) Qty 8 pieces for models VPVL-051 through 600; Qty 12 pieces for model VPVL-700

(3) For models VPVL500 through VPVL700, right and left end-caps are symmetric

HOW TO ORDER

To specify a complete VALV-POWR VALUE-LINE Actuator, simply make a selection from the code boxes below.

EXAMPLE: VPVL 400 SR4/5 B AS C, shown below, is a 59 FT•LBS 60-psi (84 N•m @ 4.2 bar) spring-return actuator with spring-to-close rotation, hard-anodized PTFE-coated body, polyester-coated end caps, standard temperature rating, and 100% adjustable travel stops.

1	2	3	4	5	6	7
VPVL	400	SR4/5	B	AS	C	—

NOTE: for multiple options, specify them in order as listed in Item 5, for example: VPVL400 SR4/5 B HT AS Model C.

1	Product Group
VPVL	VALV-POWR VALUE-LINE Double-Opposed Piston Actuator

2	Size
011, 051, 100, 200, 250, 300, 350, 400, 450, 500, 550, 600, 650, 700, 800	Select from torque table

3	Series+
DA	VALV-POWR VALUE-LINE Double-Opposed Piston Actuator
SR4/5	Spring-Return 60-psi (4.1 bar) Spring-to-Close (CW Rotation)
SR6	Spring-Return 80-psi (5.5 bar) Spring-to-Close (CW Rotation)

+ Other spring rates on application

4	Exterior Protection*
B	Hard-Anodized PTFE-Coated Body & Polyester-Coated End Caps

* Consult factory for other protection options.

5	Options
—	Standard Temperature Rating: -4°F to +175°F (-20°C to +80°C)
HT	High-Temperature Rating: -4°F to +300°F (-20°C to +150°C)
LT	Low-Temperature Rating: -40°F to +175°F (-40°C to +80°C)
LX	Low-Temperature Rating: -60°F to +175°F (-51°C to +80°C)
FO	Spring-to-Open (CCW Rotation)
AS	100% Travel Stop
LD	Mechanical Safety Lockout

Note* "LX" option must be ordered complete from the factory.

6	Model
C	Model C

7	Modifier Code
—	Standard
XB	ATEX Approval

Subject to change without prior notice.

Metso Automation Inc.

Europe, Levytie 6, P.O. Box 310, 00811 Helsinki, Finland.
Tel. +358 20 483 150. Fax +358 20 483 151

North America, 44 Bowditch Drive, P.O. Box 8044, Shrewsbury, MA 01545, USA.
Tel. +1 508 852 0200. Fax +1 508 852 8172

Europe, 6-8 rue du Maine, 68271 Wittenheim Cedex, France.
Tel. +33 (0)3 89 50 64 00. Fax +33 (0)3 89 50 64 40

South America, Av. Independência, 2500- Iporanga, 18087-101, Sorocaba-São Paulo
Brazil. Tel. +55 15 2102 9700. Fax +55 15 2102 9748/49

Asia Pacific, 238A Thomson Road, #25-09 Novena Square Tower A, 307684 Singapore.
Tel. +65 6511 1011. Fax +65 6250 0830

China, 19/F, the Exchange Beijing, No. 118, Jianguo Lu Yi, Chaoyang Dist, 100022 Beijing, China.
Tel. +86-10-6566-6600. Fax +86-10-6566-2575

Middle East, Roundabout 8, Unit AB-07, P.O. Box 17175, Jebel Ali Freezone, Dubai,
United Arab Emirates. Tel. +971 4 883 6974. Fax +971 4 883 6836

www.metso.com/automation

