

Q7130A, Q7230A, Q7330A Modutrol IV Interface Modules

INSTALLATION INSTRUCTIONS

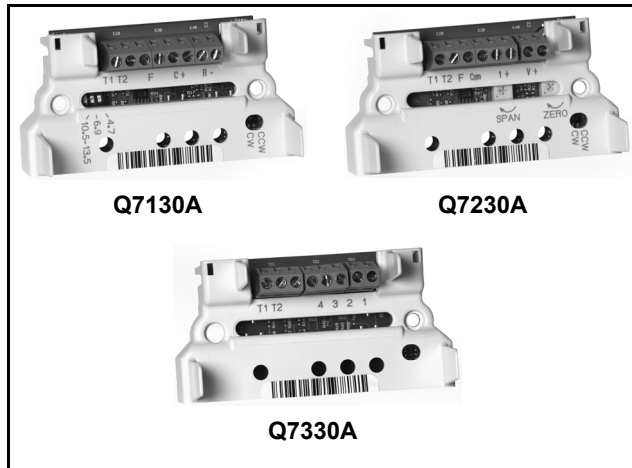

FEATURES

- Mounts inside the wiring box of any Series 90 Modutrol IV Motor (M91XX models). Module protected from weather by the Modutrol IV NEMA 3 wiring box.
- Mates to quick-connect terminals in motor wiring box and provides screw terminals for control wiring connections.
- Features solid state circuitry with surface mount components.
- Plastic enclosure provides easy handling and protection for circuitry.
- Q7130A provides selectable voltage range (4-7, 6-9, or 10.5-13.5 Vdc). Adapts M91XX Modutrol IV Motor to function as M71XX model for M734H,J, M744D, M745G,P replacements. Includes reversing switch to allow replacement of electrically normally open or electrically normally closed motors.
- Q7230A provides current or voltage control (4-20 mA and 2-10 Vdc) with adjustable zero and span. Adapts the M91XX Modutrol IV Motor to function as M72XX model for M744S,T,Y or M745S,T,Y replacements. Includes reversing switch to allow replacement of electrically normally open or electrically normally closed motors.
- Q7330A is an interface to W936 and W945 controls. Adapts the M91XX Modutrol IV Motor to function as M73XX model for M734D, M744A, M745A replacements.

APPLICATION

The Q7130, Q7230, and Q7330 Modutrol IV Interface Modules are used with Series 90 Modutrol IV Motors (M91XX) for conversion to electronic (Series 70) control.



SPECIFICATIONS

IMPORTANT:

The specifications given in this publication do not include normal manufacturing tolerances. Therefore, this unit may not exactly match the listed specifications. Also, this product is tested and calibrated under closely controlled conditions and some minor differences in performance can be expected if those conditions are changed.

Input Impedance:

Q7130A: >100k ohms.
 Q7230A: voltage input >100k ohms; current input 67 ohms.

Temperature Rating: -40° F to +150° F [-40° C to + 66° C].

Dimensions: See Fig. 1.

Models:

- Q7130A Modutrol IV Interface Module:
 Used with M91XX Modutrol IV Motor to replace M71XX Motor applications. Module controls only one motor. See Table 1.
- Q7230A Modutrol IV Interface Module:
 Used with M91XX Modutrol IV Motor to replace M72XX Motor applications. Module controls only one motor. See Table 1.
- Q7330A Modutrol IV Interface Module:
 Used with M91XX Modutrol IV Motor to replace M73XX Motor applications. Module controls only one motor. See Table 1.

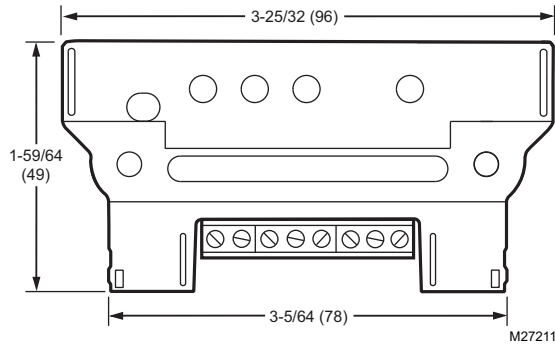

Fig. 1. Q7130,Q7230,Q7330 Modutrol IV Interface Module dimensions in in. (mm).

Electrical Ratings:

Input Voltage: 24 Vac, 50/60 Hz.

Power Consumption: 2 VA.

Table 1. Interface Module Function/Application Chart.

This Model	Provides Interface For	And Replaces These Old Style Motors ^a	When Used with Series 90 Models:
Q7130A	Selectable voltage ranges: 4-7, 6-9, or 10.5 to 13.5 Vdc	M734H	M9164D1009
		M734J	
		M744D ^b	M9184D1021
		M745G	M9185A1018
Q7230A	Adjustable zero and span, voltage or current M9184D1021 control (includes 4-20 mA and 2-10 Vdc).	M744S	M9184D1021
		M744T	
		M744Y	
		M745S	M9185D1004
		M745T	
		M745Y	
Q7330A	W936 or W945 control interface.	M734D	M9164D1009
		M744A	M9184D1021
		M745A	M9185D1004

^a Refer to customer.honeywell.com for cross-reference details.

^b M744D1037 and M744D1045 do not apply.

INSTALLATION

When Installing This Product...

1. Read these instructions carefully. Failure to follow them could damage the product or cause a hazardous condition.
2. Check the ratings and description given in this specification to make sure the product is suitable for your application.
3. Installer must be a trained, experienced service technician.
4. After installation is complete, check out product operation as provided in these instructions.

CAUTION

Disconnect power before installation to prevent electrical shock or equipment damage.

IMPORTANT:

For ease of adjustment, make all stroke and auxiliary switch adjustments before installing the interface module. After installation, access to the stroke adjust cams and auxiliary switches inside the motor is restricted. For complete details on performing these adjustments, refer to the specification sheet packed with the Modutrol Motor.

Installing Terminal Block

CAUTION

When installing the terminal block on the motor quick connects, push the board straight down. Rocking or tilting of the board can damage the electrical connectors and result in an inoperative wiring module.



1. Disconnect power from the M91XX Modutrol IV Motor to prevent electrical shock or equipment damage.
2. Remove wiring box cover from the motor by removing four screws.
3. Disconnect all field wiring from the motor.
4. If motor has an internal transformer, make sure transformer is not powered and disconnect secondary wires from T1 and T2 terminals. Clip quick-connect terminations from transformer secondary (brown) wires. Trim 1/8 to 1/4 in. (3 to 6 mm) of insulation from the ends of the wire. Tin wire ends with solder.
5. Plug terminal block onto quick-connect terminals inside wiring box.
6. Connect field wiring to screw terminals on terminal block. See Fig. 2, 4, and 8 for terminal designations. Trim wire ends neatly and tin with solder.
7. Position circuit module and secure.

SETTINGS AND ADJUSTMENTS

Module Adjustments

Q7130A Adjustments (Fig. 2)

The Q7130A provides selectable range, two-wire voltage control (4-7, 6-9 or 10.5-13.5 Vdc). It includes a clockwise/counterclockwise (cw/ccw) switch for replacing electrically normally open or electrically normally closed motors. Remove film on switch before use.

1. Select desired voltage range using the three-position switch.
2. Select desired rotation. Select cw for electrically normally closed (motor drives clockwise , as viewed from power end, to open with an increase in control signal). Select ccw for electrically normally open (motor drives counterclockwise , as viewed from power end, to close with an increase in control signal).
3. See Fig. 3 for typical system wiring.
4. Set controller to drive motor to fully open position and then to fully closed position to check for proper operation. (See Table 2.)

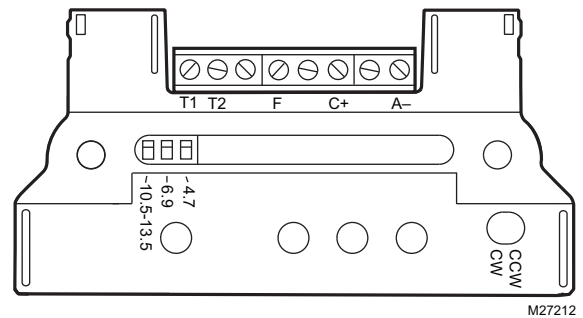

M27212

Fig. 2. Q7130A terminals and adjustments.

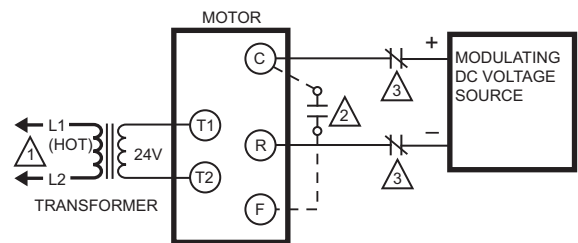

1. POWER SUPPLY. ADD DISCONNECT MEANS AND OVERLOAD PROTECTION AS REQUIRED.
2. OPTIONAL NORMALLY OPEN SWITCH. WITH CCW SELECTION, MOTOR WILL RUN TO FULLY CLOSED; WITH CW SELECTION MOTOR WILL RUN TO FULLY OPEN WHEN THIS SWITCH CLOSSES (AS LONG AS POWER IS APPLIED TO T1, T2 TERMINALS).
3. OPTIONAL NORMALLY CLOSED SWITCHES. FINE SILVER OR DRY CONTACTS REQUIRED. WITH CCW SELECTION, MOTOR WILL RUN TO FULLY OPEN; WITH CW SELECTION, MOTOR WILL RUN TO FULLY CLOSED WHEN SWITCH IN EITHER C OR R LEAD IS OPENED.

M505C

Fig. 3. Typical system wiring for Q7130A Interface Module and M91XX Modutrol Motor.

Table 2. Q7130A/M91XX Checkout Procedure.

Step	Proper Motor Response Switch in Clockwise Position	Switch in Counterclockwise Position
1. Open terminal C or R.	Motor runs closed (fully ccw).	Motor runs open (fully cw).
2. Jumper terminals C and F.	Motor runs fully open (fully cw).	Motor runs fully closed (fully ccw).
3. Remove either T terminal or disconnect power supply.	Spring return motors return to normal spring position (fully ccw ↶ for mechanically normally closed motors; fully cw ↷ for mechanically normally open motors).	

Q7230 Adjustments (Fig. 4 and Table 3)

The Q7230A provides adjustable range (zero and span) for two-wire current or voltage control. Separate potentiometers are provided on the circuit module for adjusting the zero point and the span. It includes a cw/ccw switch for configuring the motor to rotate clockwise or counterclockwise with an increase in control signal.

1. Verify that the zero potentiometer is fully clockwise and that the span potentiometer is fully counterclockwise.
2. Select desired rotation direction [cw (electrically normally closed) is the most common]. The following directions apply for the clockwise setting. For counterclockwise setting, reverse open and closed, and reverse clockwise and counterclockwise. Remove film on switch before use.
3. See Fig. 6 and 7 for typical system wiring.
4. For current control, connect the current input signal to I+ (screw terminal 3) and COM (screw terminal 5). For voltage control, connect the voltage input signal to V+ (screw terminal 1) and COM (screw terminal 5).
5. Set the controller to output the signal required to drive the motor to the closed position. Wait for the motor to stop driving closed.
6. Turn the zero potentiometer slowly counterclockwise ↶ until the motor starts to open.
7. Turn the zero potentiometer slowly clockwise ↷ until the motor is fully closed. This is defined as the zero setting.

8. Set the controller to output the signal required to drive the motor to the fully open position. Wait for the motor to stop driving open.
9. Turn the span potentiometer slowly clockwise ↷ until the motor starts to drive closed. The difference between the fully open position signal and the fully closed position signal is defined as the operating span.
10. Recheck the fully closed position and readjust the zero potentiometer, if necessary. (Turn the zero potentiometer clockwise ↷ to close the motor and counterclockwise ↶ to open the motor.)

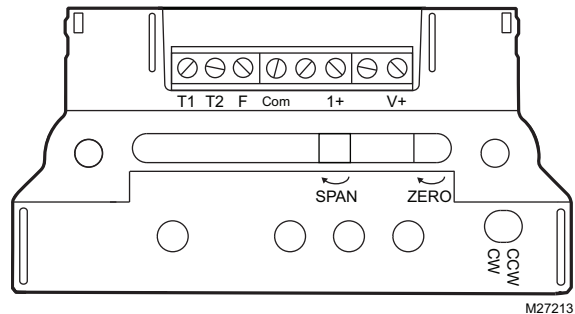

Fig. 4. Q7230A terminals and adjustments.

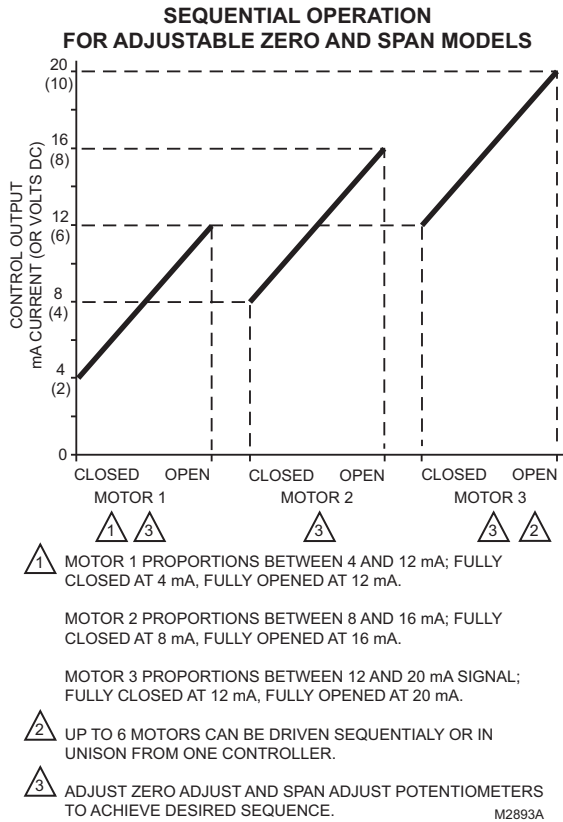

Fig. 5. Sequential operation of three motors with Q7230A Interface Module.

11. Recheck the fully open position and readjust the span potentiometer, if necessary. (Turn the span potentiometer clockwise to close the motor, counterclockwise to open the motor.)
12. For sequential operation at two or more motors (as shown in Fig. 5), repeat the above steps for each motor, individually adjusting each for the desired response to the input signal.

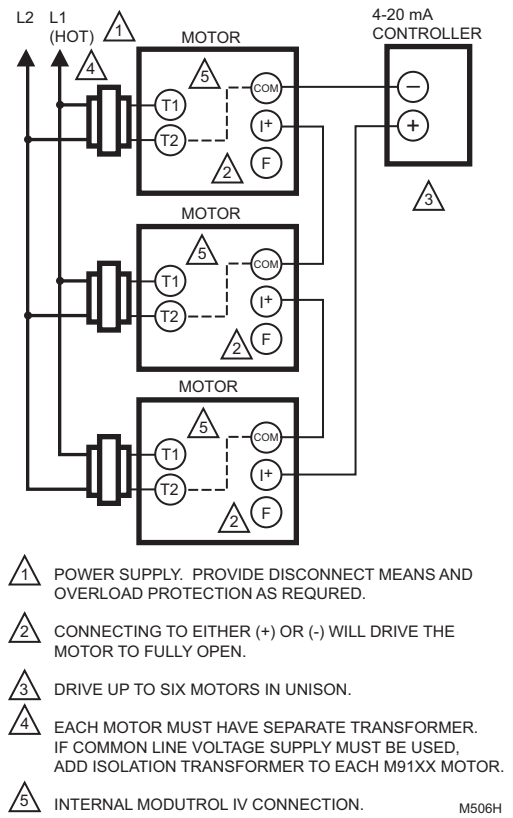

Fig. 6. Typical wiring diagram for Q7230A Interface Module and M91XXX Modutrol IV Motor with 4-20 mA controller.

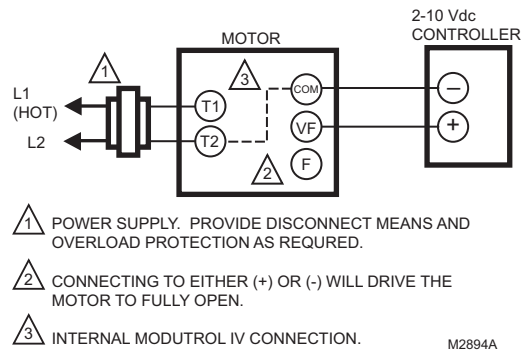

Fig. 7. Typical wiring diagram for Q7230A Interface Module and M91XXX Modutrol IV Motor with 2-10 Vdc controller.

Table 3. Q7230/M91XX Checkout Procedure.

Step	Proper Motor Response Switch in Clockwise Position	Switch in Counterclockwise Position
1. Open terminals (+), (-), F	Motor closes fully ccw	Motor opens fully cw
2. Jumper F to (-)	Motor opens fully cw	Motor closes fully ccw
3. Remove either T terminal	Spring return motors return to normal spring position (fully ccw ↶ for mechanically normally closed motors, fully cw ↷ for mechanically normally open motors).	

(+) and (-) denotes terminals on the controller

Q7330A Adjustments (Fig. 8 and Table 4)

The Q7330A provides control interface for W936 and W945 controllers. This module consists only of the terminal block and does not require any adjustments. See Fig. 8 for terminals.

After the motor stroke is adjusted (if necessary), simply plug the module onto the motor quick-connect terminals and secure to the motor. See Fig. 9 for typical system wiring.

To check proper motor operation:

1. Provide power to the motor.
2. Jumper terminals 1 and 2 to drive motor open (clockwise ↷ as viewed from power end).
3. Jumper terminals 1 and 3 to drive motor closed. Connect field wiring to appropriate screw terminals.

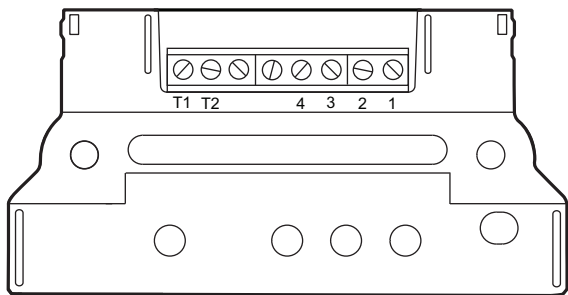
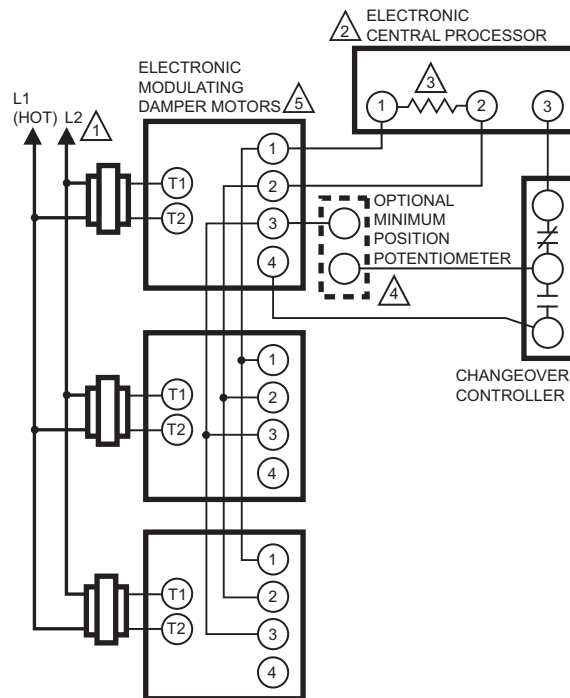

Fig. 8. Q7330A terminals.









- 1 POWER SUPPLY. PROVIDE DISCONNECT MEANS AND OVERLOAD PROTECTION AS REQUIRED.
- 2 SEE APPROPRIATE SYSTEM CONTROL INSTRUCTIONS FOR CONNECTIONS TO CENTRAL PROCESSOR. (LABELED E1 ON W936 OR T1 ON W945).
- 3 FIVE PERCENT CARBON RESISTOR. VALUE VARIES WITH NUMBER OF MOTORS PARALLELED (1000 OHMS/2 MOTORS, 820 OHMS/3 MOTORS).
- 4 AUTHORITY OF MINIMUM POSITION POTENTIOMETER IF USED, INCREASES WITH NUMBER OF MOTORS PARALLELED (135 OHMS ON MOTOR/50 PERCENT STROKE, ON 2 MOTORS/100 PERCENT STROKE, ON 3 MOTORS/150 PERCENT STROKE).
- 5 USE AUXILIARY END OF M9185 TO REPLACE M945B; M745D MOTORS TO SPRING RETURN TO THE NORMALLY OPEN POSITION.

M487C

Fig. 9. Typical wiring diagram for Q7330A Interface Module and M91XX Modutrol IV Motor.

Table 4. Q7330/M91XX Checkout Procedure.

Step	Proper Motor Response for Normally Closed Motor	Proper Motor Response for Normally Open Motor
1. Disconnect leads from terminals 1,2,3,4.	Motor closes. (Fully ccw  as viewed from power end).	Motor opens. (Fully cw  as viewed from the power end)
2. With motor powered jumper terminals 1 and 2.	Motor drives open (clockwise  as viewed from powered end).	Motor drives closed (counterclockwise  as viewed from the power end).
3. Remove either T terminal or disconnect power supply.	Spring return motors return to normal spring position (fully ccw  for mechanically normally closed motors, fully cw  for mechanically normally open motors).	
4. Jumper terminals 1 and 3.	Motor drives closed.	Motor drives open.

Automation and Control Solutions

Honeywell International Inc.
1985 Douglas Drive North
Golden Valley, MN 55422
customer.honeywell.com

Honeywell Limited-Honeywell Limitée
35 Dynamic Drive
Toronto, Ontario M1V 4Z9

