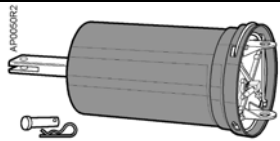


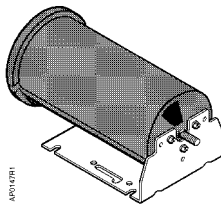
## Powers™ Controls

OEM Literature

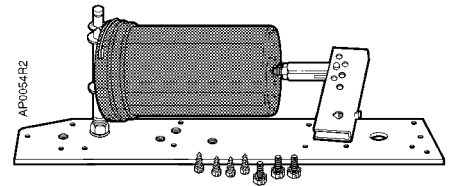
### No. 4 Pneumatic Damper Actuator



**Pivot Mount Actuator  
 with Clevis, Clevis Pin,  
 and Hitch Pin Clip**



**Actuator with Fixed Bracket  
 Mounted**



**Actuator with Universal Kit**

#### Description

The No. 4 Pneumatic Damper Actuator is a totally enclosed pneumatic piston type actuator designed to operate dampers for ventilating systems, mixing box control, and other applications requiring a large effective diaphragm area and long stroke.

#### Features

- All metal body modular construction
- Replaceable, ozone-resistant EPDM rubber rolling diaphragm
- Pivot mounting for extended shaft or frame mounting
- Fixed bracket mounting
- Direct front mounting
- Positioning relay (optional)
- Forward travel stops (optional)
- Adjustable hesitation point (hesitation actuator only)

#### Product Numbers

See Table 1

#### Application

The No. 4 Pneumatic Damper Actuator is recommended for control of outdoor, return air, exhaust, face and bypass, fan discharge, and static pressure control dampers, as well as specialized dampers and air valves found in terminal units such as unit ventilators and mixing boxes.

The No. 4 Pneumatic Damper Actuator is frequently used to operate dampers for fire/smoke control. These damper/actuator combinations have been tested to UL, AMCA, and NFPA standards, and are on file at UL by the damper manufacturer.



Certain actuators in Table 1 are UL Recognized Components under UL's Damper Actuator category (EMKU2). This category covers pneumatic damper actuators intended to be employed on fire dampers and fire/smoke leakage rated dampers.

**Table 1. Product Numbers for No. 4 Pneumatic Damper Actuators.**

Description	Mounting Style	Part Number			
		Nominal Spring Range			
		3-7 psi (21-48 kPa)	3-13 psi (21-90 kPa)	5-10 psi (35-69 kPa)	8-13 psi (55-90 kPa)
Actuator, three mounting screws, bracket no included	Shaft end	331-2910	—	331-2917	331-2963
Actuator with fixed bracket mounted	Shaft end	331-2911	—	331-2934	331-2966
Actuator, integral pivot, clevis, and clevis pin for use with frame mounting accessory	Pivot	331-2904* 331-2929	331-2905 331-2930	331-2906* 331-2931	331-2961* 331-2968
Actuator, integral pivot with pivot post mounted on plate for extended shaft mounting with clevis and crank for 3/8, 7/16, or 1/2-inch (10, 11, or 13 mm) diameter shaft. Parts for frame mounting (blade drive) included with kit.	Universal kit	331-3000	331-3001	331-3002	331-2973*
Contact Siemens OEM Sales for details.	OEM specials	—	—	331-2976*	331-2995* 331-2998*
Any above with positioning relay	Positioner relays can be ordered for factory mounting on any of the above actuators. To order an actuator with a factory-mounted positioner relay, change the third digit in the actuator part number from a 1 to a 2. For example, 331-2961 becomes 332-2961 when ordered with a factory-mounted positioner relay. You may also order the positioner relay separately from the actuator. Be certain to order both the relay AND the mounting kit. See the <i>Accessories</i> section for details.				

\* UL Recognized Component.

**NOTE:** When an actuator is ordered with universal mounting, the mounting plate, pivot post and hardware, clevis, damper crank, and all screws/nuts are included. To order frame mounting accessories if not supplied by the damper manufacturer, contact Siemens Building Technologies, Inc.

Specifications		
Effective diaphragm area		11 inches <sup>2</sup> (71 cm <sup>2</sup> )
Stroke		4 inches (102 mm)
Stroke (Hesitation model)		3 inches (76 mm)
Stem		Stainless steel
Housing		Steel with cathodic epoxy electrocoat
Diaphragm		EPDM rubber
Bearing		Oilite® sintered bronze bushing in aluminum die casting
Maximum Air Pressure		25 psig (172 kPa)
Nominal Spring Ranges		3 to 7 psi (21 to 50 kPa) 3 to 13 psi (21 to 90 kPa) 5 to 10 psi (35 to 70 kPa) 8 to 13 psi (55 to 90 kPa)
Nominal Spring Range (Hesitation model)		2 to 3; 8 to 13 psi (14 to 21; 55 to 90 kPa)
Ambient temperature range	Operating Storage	-20°F to 200°F (-29°C to 93°C) -20°F to 200°F (-29°C to 93°C)

**Specifications,  
 Continued**

Air Connection	Elbow barb fitting for 1/4-inch OD plastic tubing installed in 1/8-inch NPT opening
Mounting	Front, bracket, pivot
Thrust and Torque Rating	See Table 2
Dimensions	See Figures 7 through 11
Agency Approvals	Complies with UL555 and UL555S

**NOTE:** The No. 4 Pneumatic Damper Actuator does not require any periodic cycling. However, it is strongly suggested that all systems are functionally checked periodically, and per local codes and ordinances.

**Table 2. Thrust Torque Ratings.**

Nominal Spring Range	Maximum Thrust lbs. (N)				Torque Rating * lb-in (Nm)			
	Full Stroke Forward			Spring Return (No stroke) 0 psig (0 kPa)	Gradual Operation	2-position Operation or Positioner		
	15 psi (103 kPa)	18 psi (124 kPa)	25 psi (172 kPa)			15 psi (103 kPa)	18 psi (124 kPa)	25 psi (172 kPa)
3-7 psi (21-50 kPa)	88 (391)	121 (538)	198 (881)	33 (147)	30 (3.4)	46 (5.2)	46 (5.2)	46 (5.2)
3-13 psi (21-90 kPa)	22 (98)	55 (245)	132 (587)	33 (147)	30 (3.4)	30 (3.4)	46 (5.2)	46 (5.2)
5-10 psi (35-70 kPa)	55 (245)	88 (391)	165 (734)	55 (245)	30 (3.4)	77 (8.7)	77 (8.7)	77 (8.7)
8-13 psi (55- 90 kPa)	22 (98)	55 (245)	132 (587)	88 (391)	30 (3.4)	30 (3.4)	77 (8.7)	124 (14)
2-3, 8-13 psi (14-21, 55-90 kPa) Hesitation model	22 (98)	55 (245)	132 (587)	22 (98)	23 (2.6)	—	—	—

\* With maximum hysteresis of 2.5 psi (17.2 kPa) @ 90° rotation.

**Accessories**

**Actuator shaft extensions:**

11-7/8 inch extension kit, includes 5/16 inch diameter rod, 1/4 - 28 ball joint connector, and actuator shaft adapter 331-674

Actuator shaft extension kit, includes shaft/clevis adapter, clevis adapter rod and nuts 333-030

**Clevises:**

OEM Stamped metal clevis (requires nut 041-143k) 333-191

Machined steel clevis 333-207

Cast metal (forged) clevis 331-653

Plastic clevis 331-801

**Clevis Pins:**

15/16-inch long 331-292

1-5/32 inch long 331-918

Hitch pin clip for preceding clevises 331-807

**Accessories,  
 Continued**

---

<b>Damper shaft crank (U channel) assemblies:            (includes crank and hold down nut)</b>	
For 1/2-inch damper shaft	331-941
For 5/8-inch damper shaft	333-182
For 3/4-inch damper shaft	333-183
For 1-inch damper shaft	333-181
<b>Damper shaft crank arms with selectable radius:</b>	
For 1/2-inch damper shaft, adjustable from 3/4 to 2-7/8 inch radius	331-795
<b>Damper shaft extensions:</b>	
1/2-inch diameter, 2-1/4 inch long extension	331-631
1/2-inch diameter, 9 inch long extension	333-042
For 1/2-inch hollow shaft, 6 inch long extension	333-184
3/8 to 1/2-inch shaft adapter	331-632
<b>Linkage Kits and components:</b>	
3/8 - 24 ball joint connector, threads onto output shaft of actuator connects to 5/16 inch diameter push rod (331-658x)	331-656
1/4 - 28 ball joint connector (for use with shaft extension 331-956 or shaft extension kit 331-674)	331-657
Linkage kit, includes both ball joint connectors above, plus 4-inch long, 5/16 diameter rod shaft extension, and crank assembly 333-081	331-947
Linkage kit, includes 4-inch long, 1/8 inch thick link, two clevis pins, and crank assembly	331-958
Linkage kit, includes 5-11/32 inch long pivot post, 1/4 - 28 ball joint connector, damper shaft crank arm (331-795), 1/2-inch shaft extension (331-956), and miscellaneous hardware (nuts, washers, etc.)	331-954
<b>Mounting posts, brackets and hardware:</b>	
Standard length, 5-11/32 inch, pivot post	331-547
Extended length, 7-1/3 inch, pivot post	331-565
Pivot post mounting kit, includes extension length pivot post, E-ring clips, miscellaneous hardware	333-045
Universal mounting plate	
3/4-inch damper shaft	331-623
1-inch damper shaft (use with 333-194)	331-623A
Fixed mounting bracket (requires three mounting screws 331-931)	331-916
<b>Positioning Relay and Mounting Kits:</b>	
Positioning Relay	147-2000
Positioning Relay mounting kit, includes, mounting bracket, actuator shaft clevis, feedback assembly, and misc. hardware	147-314

---

**Service Kits**

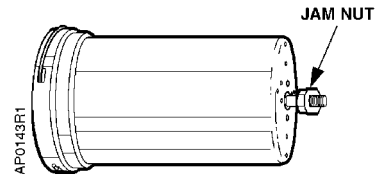
Diaphragms (package of five)

333-071



**WARNING:**

Do not remove the jam nut. The spring is under a heavy load. Repair by trained personnel only.



**Figure 1. Actuator Jam Nut Location.**

**Actuator Sizing**

The quantity of actuators required depends on several torque factors. To determine the quantity of actuators required for the installation:

- Obtain damper torque ratings (ft-lb/ft<sup>2</sup>) from the damper manufacturer.
- Determine the area of the damper.
- Calculate the total torque required to move the damper:

$$\text{Total Torque} = \text{Torque Rating} \times \text{Damper Area}$$

- Calculate the total quantity of actuators required:

$$\text{Number of Actuators} = \frac{\text{Total Damper Torque Required}}{\text{SF}^1 \times \text{Actuator Torque (Table 2)}}$$

**Safety Factor**

<sup>1</sup> Safety Factor: When calculating the number of actuators required, a safety factor should be included for unaccountable variables such as slight misalignments, aging of the damper, etc. A suggested safety factor is 0.80 (or 80% of the rated torque).

See *AB-300 Damper Actuator Sizing and Selection Application Bulletin in the HVAC Systems/Controls Reference Data* (125-1853) for additional sizing information. See *TB-181 Powers™ Controls Maximum Thrust Ratings of Pneumatic Damper Actuators Technical Bulletin* (155-219P25) for additional torque requirements.

## Operation

### Standard Actuator (Figure 2)

The air tubing from a controlling instrument connects to the actuator's upper housing. With no control pressure to the actuator, the compression spring forces the diaphragm and actuator shaft toward the upper housing, but is limited by the jam nut on the actuator shaft. As the control pressure on the diaphragm increases, the spring compression is overcome and the actuator shaft gradually moves outward. Conversely, as control pressure decreases, the spring returns the shaft to the position at which the air pressure on the diaphragm balances the spring tension. For each value of control pressure there is a corresponding position of the shaft.

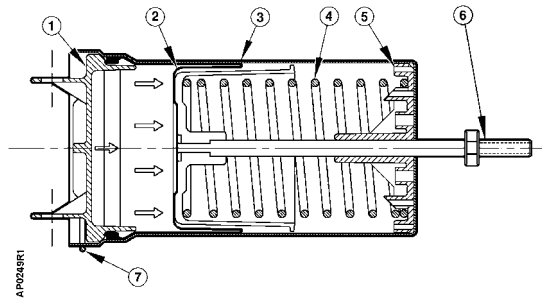
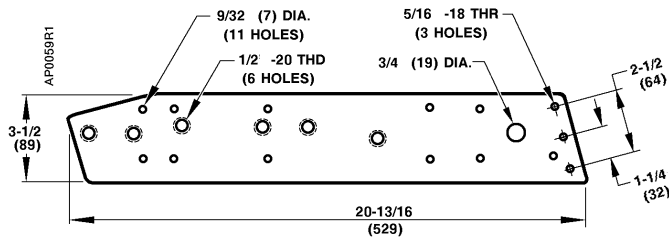


Figure 2. Standard Actuator.

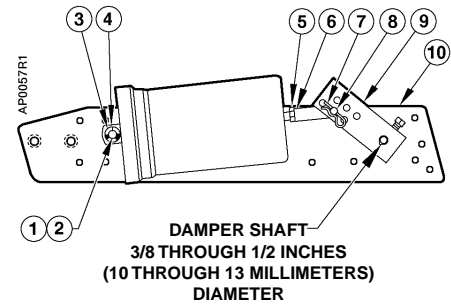
Table 3. Construction Components (Figure 2).

Item	Part Number	Material	Description
1	333-099	Aluminum	Upper Housing with Pivot Ears
2	333-571	Silicone	Diaphragm (package of 5)
3	—	Steel	Lower Housing
4	—	Oil-tempered Steel	Spring
5	—	Zytel	Bearing Plate
6	—	—	Piston Cup and Stem
7	331-915	Music Wire	Retainer Clip

**Operation,  
 Continued**



**Figure 3. Actuator Mounting Plate.**



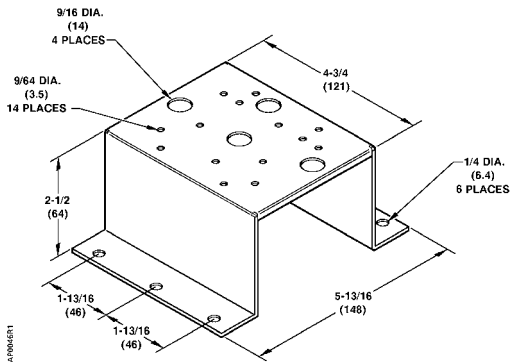
**Figure 4. Actuator Accessories.**

**Table 4. Actuator Accessories (Figures 3 and 4).**

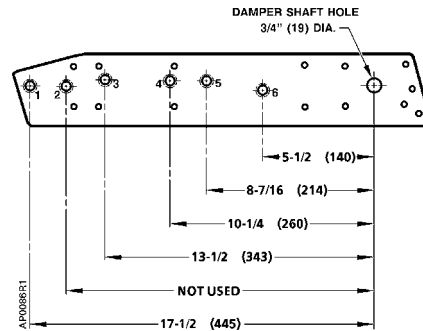
Item	Part No.	Description	Qty.	Material
1	331-565	Pivot shaft	1	Steel
2	047-061J	E-ring	2	Steel
3	146-020K	Lock washer	1	Steel
4	041-162J	Nut	1	Steel
5	041-142	Nut	1	Steel
6	333-207	Clevis	1	Zinc plated steel
7	331-807	Hitch pin	1	Zinc plated steel
8	331-293	Clevis pin	1	Zinc plated steel
9	331-923	Crank assembly	1	Zinc plated steel
10	331-623	Actuator mounting plate	1	Steel
—	034-283	Mounting screws	4	Steel
F	333-034	Rocker	—	Zinc plated steel
F	034-123K	Mounting screws	3	Steel
F	041-230J	Nut	2	Steel
F	030-510J	Screws	2	Steel

“F” Parts for Frame Mounting.

**Operations,  
 Continued**

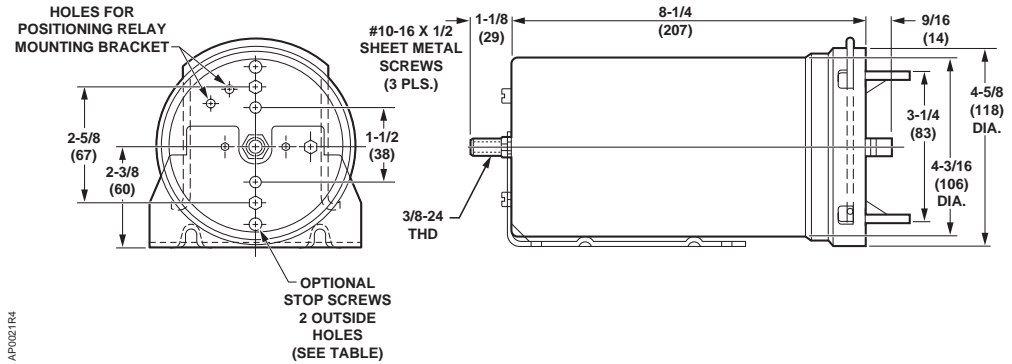


**Figure 5. Offset Mounting Bracket  
 331-186.**

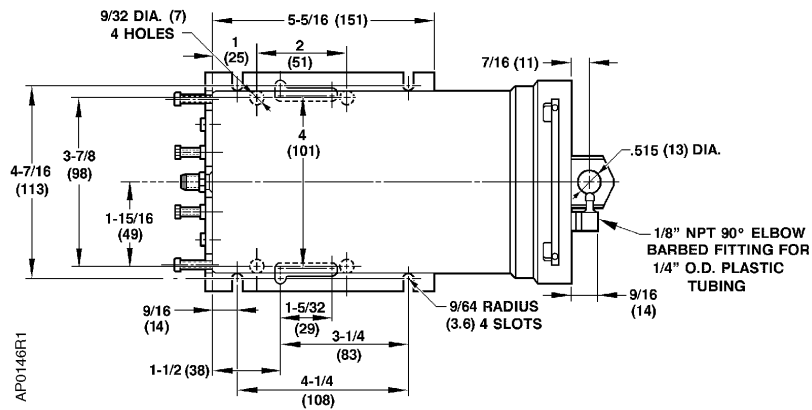


**Figure 6. Actuator Mounting Plate  
 331-623.**

**Dimensions**

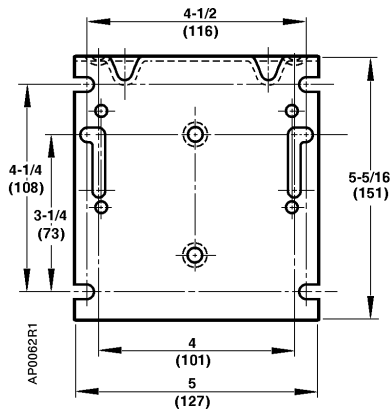


**Figure 7. Dimensions Shown in Inches (mm).**

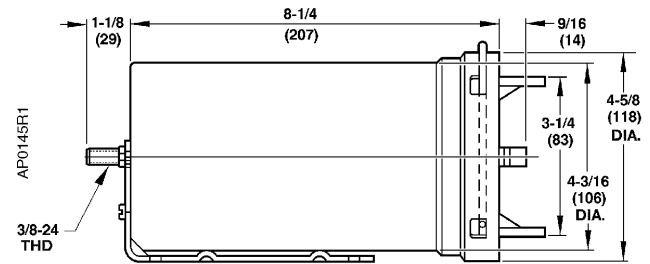


**Figure 8. Dimensions Shown in Inches (mm).**

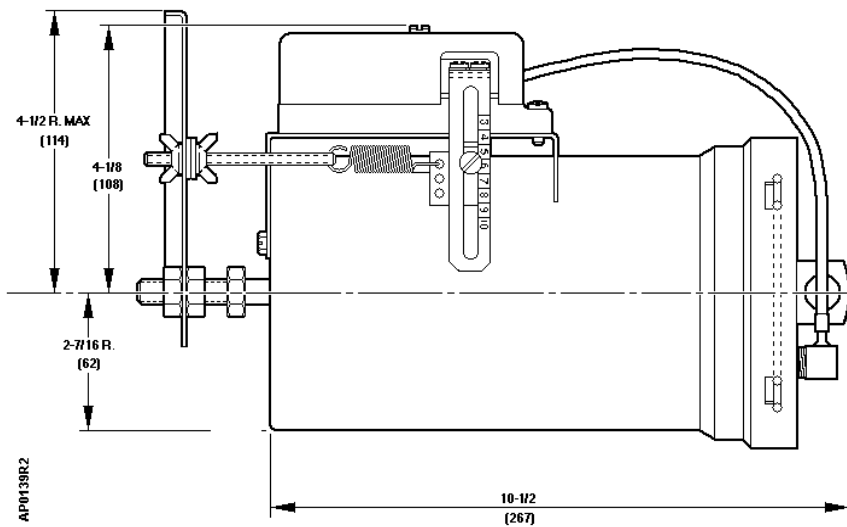
**Dimensions,  
 Continued**



**Figure 9. Fixed Bracket  
 Dimensions in Inches (mm).**



**Figure 10. Fixed Mount Actuator  
 Dimensions in Inches (mm).**



**Figure 11. No. 4 Pneumatic Damper Actuator with the RL 147 Positioning Relay Mounted.  
 Dimensions in Inches (mm).**

Information in this publication is based on current specifications. The company reserves the right to make changes in specifications and models as design improvements are introduced. Powers is a trademark of Siemens Building Technologies, Inc. Oilite is a registered trademark of Beemer Precision, Inc. Other product or company names mentioned herein may be the trademarks of their respective owners. © 2003 Siemens Building Technologies, Inc.