

Installation, Operation, and Maintenance Instructions

This manual is the property of the owner, and is required for future maintenance.
 Please leave it with the owner when the job is complete.

Note: This drawing depicts how the actuator looks after installation. The louver shown is intended to be a general representation and the actual louver model may vary.

Reference the drawing on page 2 for an exploded view and parts list.

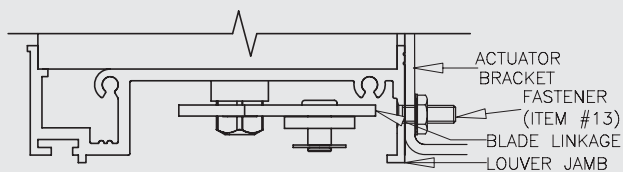
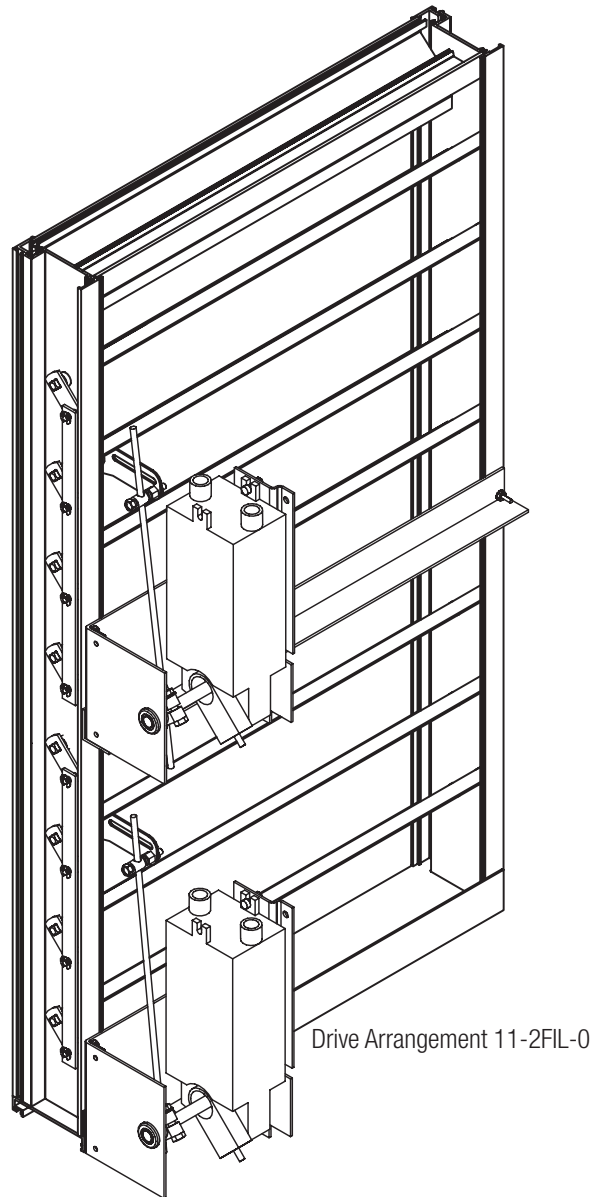
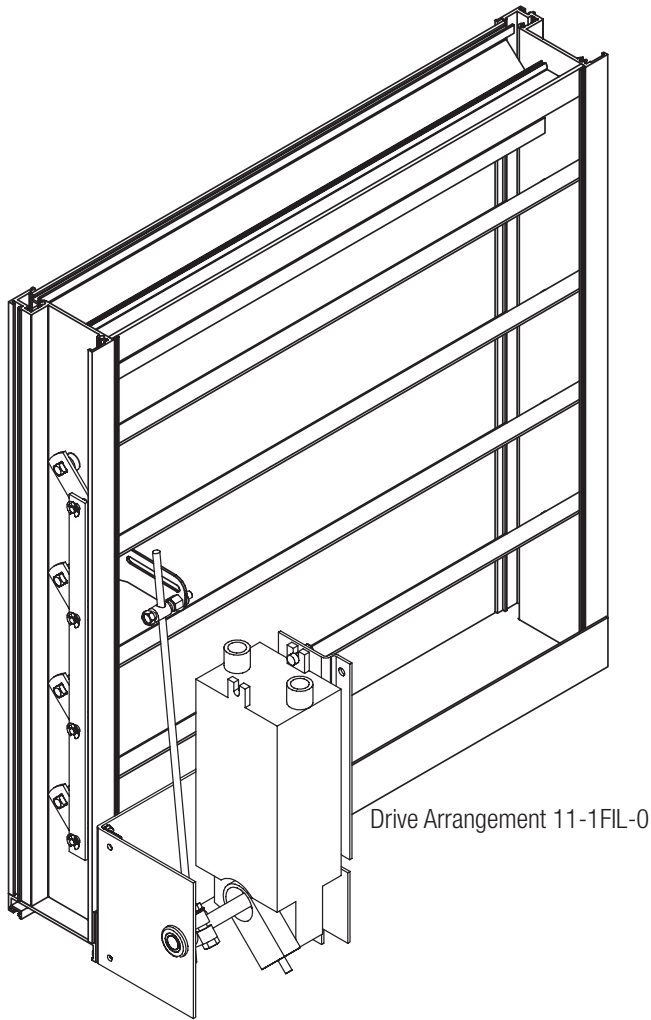

CAUTION: ATTACHING MOUNTING BRACKET WITH FASTENERS OTHER THAN AS SHOWN ABOVE CAN INTERFERE WITH BLADE LINKAGE OPERATION. ANY METHOD OTHER THAN THE ONE SHOWN IS NOT RECOMMENDED.

SAFETY WARNING:

Improper installation, adjustment, alteration, service or maintenance can cause property damage, injury or death. Read the installation, operating, and maintenance instructions thoroughly before installing or servicing this equipment.

Prior to Adjusting

1. Louver MUST BE installed level and square for blades to operate correctly.
2. Install actuator and linkage similar to the drawing on page 1 and make the following linkage adjustments. Place ball swivel at initial location as show below. Adjust crankarm on the actuator so that it is parallel with linkage rod. If unit is "Fail Open" all adjustments will need to be made with the actuator in power on position

Note: at this time the blades should flop freely.

3. Loosen nut and bolt on actuator crankarm so that crank arm rotates freely by hand.

Adjustment Process

1. With blades closed, rotate crankarm on actuator 1/8 turn toward louver from original starting point. Hold blade with ball swivel in closed position and tighten driver blade ball swivel to drive rod.
2. Rotate crankarm on actuator 1/8 turn back to original position. Tighten nut and bolt on crank arm. This will apply extra pressure to blade seals.

Note: For a multiple section unit, adjust actuators independently from each other.

Caution: Before operating louver, make sure the ball swivel on the crankarm is in the correct location. If the blades are not completely closing the ball swivel can be adjusted SLIGHTLY. An over adjustment can cause damage to the blades.

Caution: Before operating the louver, make sure the location of the ball swivel on the crankarm allows the proper travel length.

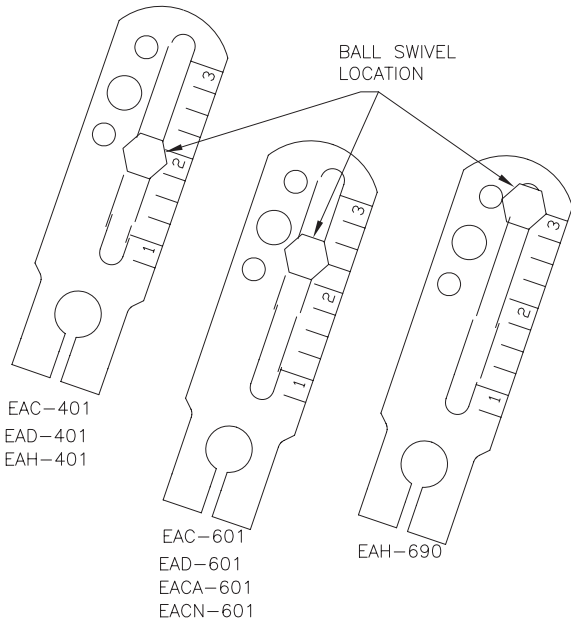
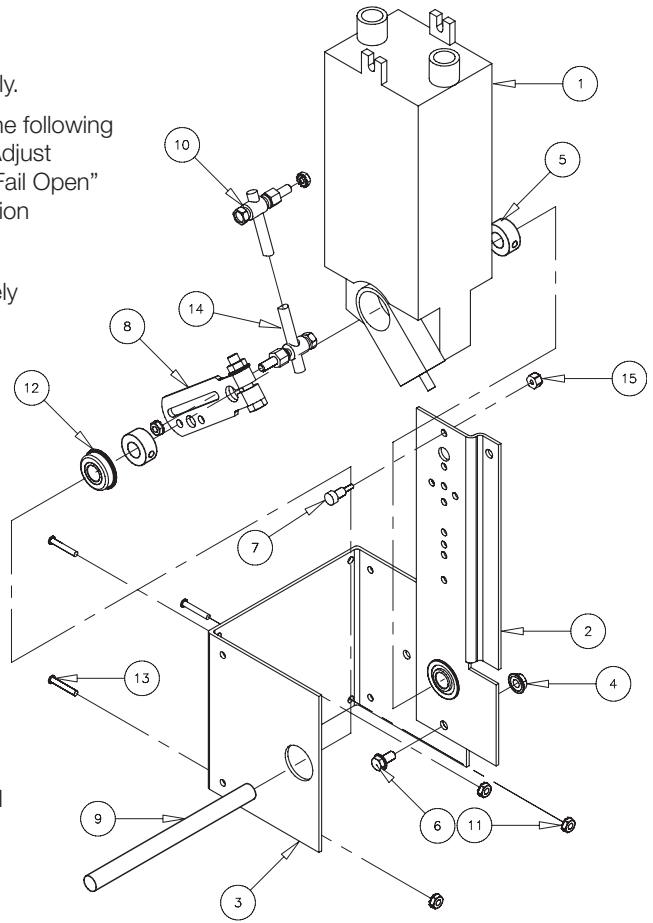

Item No.	Part No.	DA 11-1FIL-0 Qty.	DA 11-2FIL-0 Qty.	Description
1A	382823	1 Required Per Unit	2 Required Per Unit	Actuator MS4120F1006 120V
1B	382824			Actuator MS8120F1002 24V
1C	382825			Actuator MS4620F1005 230V
2	822966	1	2	Anti-Rotation Bracket Assembly
3	712711	1	2	Actuator Mounting Bracket
4	415455	1	2	1/4"-20 Nut Serrated Flange
5	451576	2	4	1/2" x 7/8" Shaft Collar
6	415034	1	2	1/4"-20 Serrated Flange Bolt
7	416048	1	2	CS, SHD. SOC. 1/4" x 3/8" ZP & Bake
8	812097	1	2	Crankarm Assembly
9	593831	1	2	1/2" Dia Rod - 6.5"
10	451554	2	4	1/4-20 Ball Swivel
11	415991	3	6	Keps Hex Nut SS
12	451582	1	2	1/2" Flgd Ball Brg No. PA-641-4
13	416010	3	6	#10-32x1 Threadstud SS
14	656473	1	2	5/16 Dia. Rod (16" long)
15	415934	1	2	Nut, #10-24 HH Nyloc ZP

It maybe necessary to adjust the swivel on the crankarm after the initial adjustments are made. This can be done by sliding the swivel in or out on the crankarm.

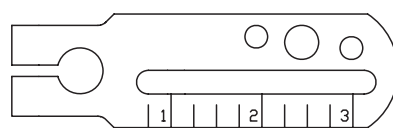

Sliding the swivel out on the crankarm will cause the blade to open more.
Sliding the swivel in on the crankarm will cause the blade to close more.



Copyright © 2006 Greenheck Fan Corporation
Honeywell Actuator
DA 11-1FIL-0 & 11-2FIL-0
December 2006

Greenheck Fan Corporation reserves the right to make product changes.