

These instructions explain how to replace blade seals in the field. Axle (shaft) penetrations through frame are protected by o-ring axle seals. The Viton o-rings may deteriorate due to abrasion, wear, oxidation or exposure to adverse chemicals. Replace as necessary. See Figure 1 & 2.

- 1) Remove actuator crankarms and interconnect linkage from axles. Smooth any burrs.
- 2) Remove external bearings and o-ring cover plate to expose the o-ring. It may be easiest to remove the o-ring stuffing box plate so as to facilitate o-ring removal.
- 3) Remove the old o-ring and the red silicone rubber gasket, if used, from the mounting surface.
- 4) Install new red silicone gasket or apply a thin layer of silicone caulk. Reinstall the o-ring stuffing box plate over the mounting studs.
- 5) Lubricate the new o-ring with petroleum jelly (Vaseline) and install into stuffing box plate.
- 6) Reinstall cover plate and external bearing. Tighten until the red silicone rubber gasket starts to squeeze from behind the o-ring stuffing box.
- 7) Reinstall drive linkage.

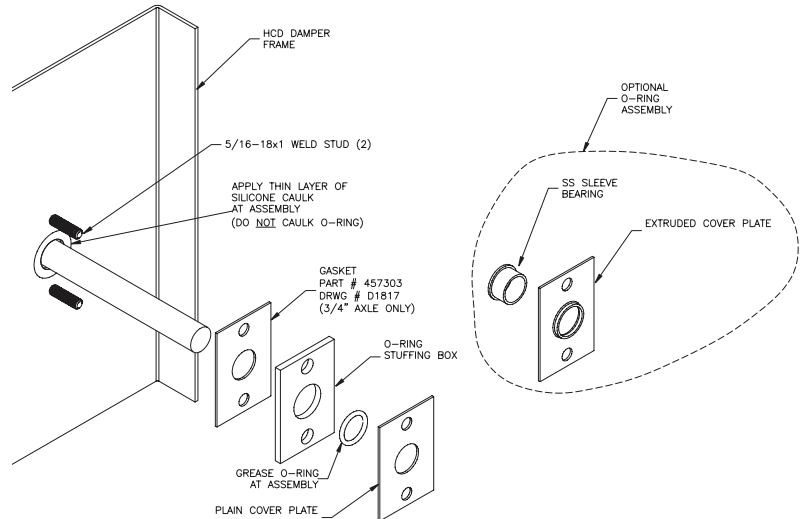

Figure 1

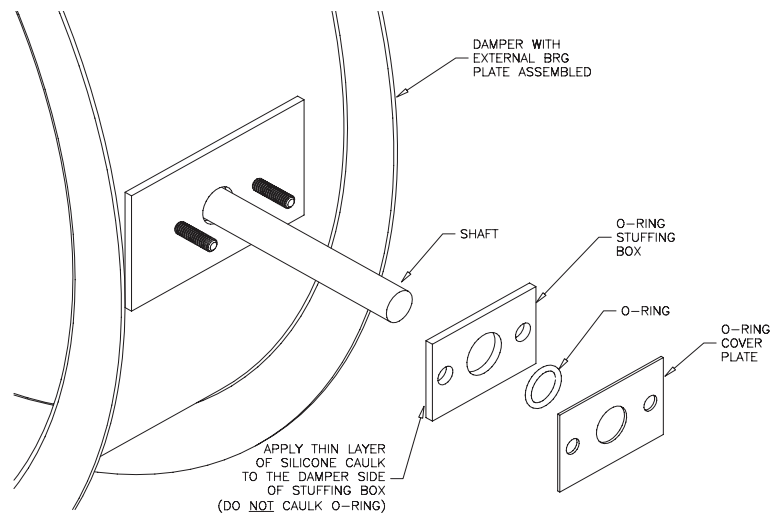

Figure 2