

These instructions apply to the internal field installation of PS Series motor packs on PS Series backdraft dampers. PS Series motor packs rotate to their energized position when power is applied and spring return to their fail position when power is interrupted.

Instructions

- Hook the actuator bracket tab (B) over the blade stop portion of the frame (A). (If a filler strip is attached to the frame, then the bracket tab should be placed between the blade stop part of the frame and the filler strip.)
- Align the actuator bracket mounting holes (C) with the prepunched holes (D) in the base of the damper frame. Insert two screws (2), as shown, and fasten securely with two nuts (4).
- Using a screw (2), nylon spacer (3), flat washer (5), and lock nut (4), attach the formed linkage bar (1) to the damper tie bar (E).
- Disconnect the spring (F) at the actuator crankarm (6).
- Rotate the crankarm clockwise until it contacts the stroke limit tab (G) of the actuator bracket.
- Open the damper blades completely. Align the slots of the actuator drive linkage (7) and the formed linkage bar (1). Install two screws and tighten securely.
- Release the damper blades. Rotate the actuator crankarm counterclockwise to close the blades. Reattach the spring (F) at the crankarm (6).
- Cycle the actuator and check the action for interference or binding of the components. Readjust if necessary.

Part #	Qty.	Description
1	1	SS Offset drive linkage
2	5	SS MS #10-32 x 1/2" PTH
3	1	Spacer, Nylon 5/16" x 0.194" x 1/8"
4	5	SS Nut, #10-32 HH Keps
5	1	SS Washer, Flat #10 0.202" x 0.437" x 0.04"
6	1	Actuator crankarm
7	1	Actuator drive linkage

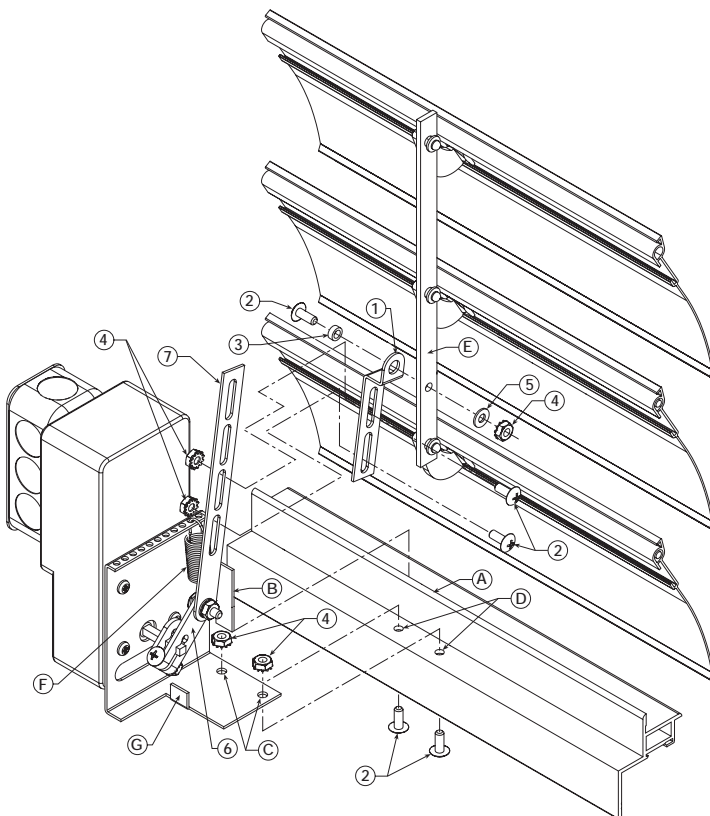

Exploded View

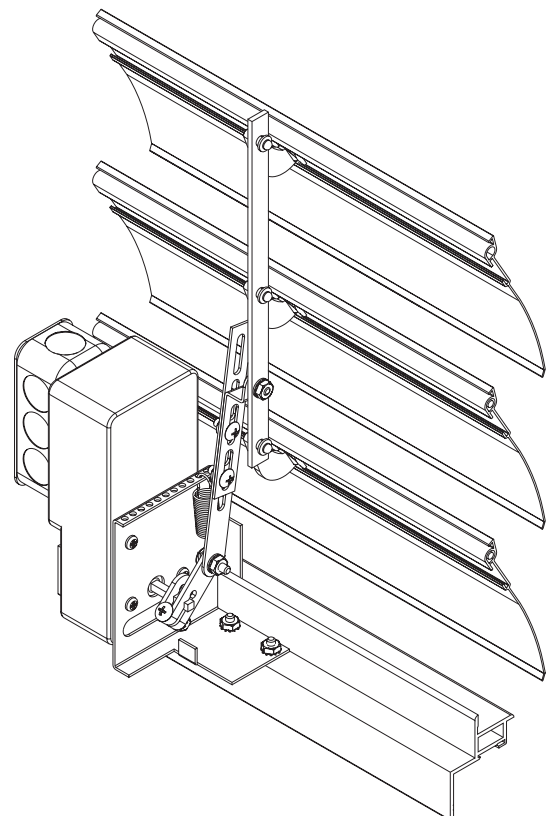

Assembled View