

# Installation, Operation, and Maintenance Instructions

This manual is the property of the owner, and is required for future maintenance. Please leave it with the owner when the job is complete.

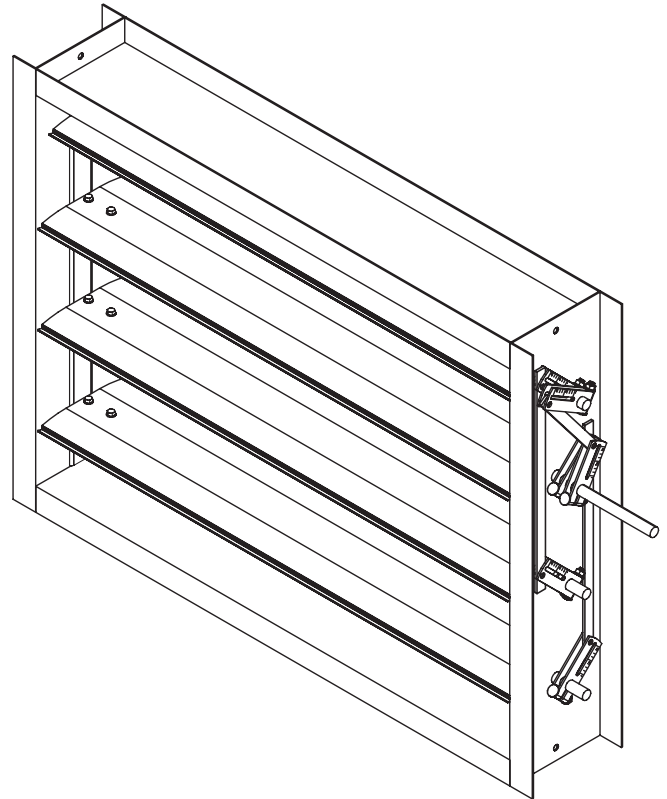
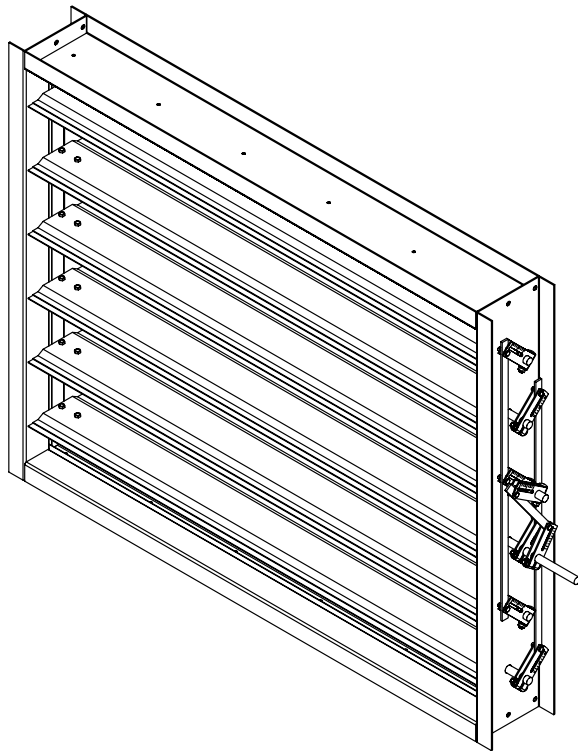

## RECEIVING AND HANDLING

Upon receiving dampers, check for both obvious and hidden damage. If damage is found, record all necessary information on the bill of lading and file a claim with the final carrier. Check to be sure that all parts of the shipment, including accessories, are accounted for.

Dampers must be kept dry and clean. Indoor storage and protection from dirt, dust and the weather is highly recommended. Do not store at temperatures in excess of 100°F (37°C).

## SAFETY WARNING:

**Improper installation, adjustment, alteration, service or maintenance can cause property damage, injury or death. Read the installation, operating, and maintenance instructions thoroughly before installing or servicing this equipment.**

Due to continuing research, Greenheck reserves the right to change specifications without notice.

## Storage of Dampers Prior to Installation

The basic intent of a proper storage of heavy duty/industrial control damper is to prevent physical damage, material corrosion, and deterioration of organic material.

- 1) Visually inspect the damper for damage. Store indoors, protected from sunlight, moisture and flooding. Protect dampers from debris and dirt accumulation. Keep all conduit entry plugs and actuator access covers in place.

## Storage of Dampers Prior to Installation cont.....

---

- 2) Dampers may be stacked and stored horizontally if wood or equivalent spacers are placed between flanges to protect finish. Do NOT store with axles vertical. Place dampers on pallets or supports to allow air circulation. Do NOT store with damper directly on concrete or ground.
- 3) The damper drive should be stored in a clean dry area. Do not stack drives on top of one another. Add desiccant to electrical compartment if storage area temperature drops below 38°F. Damage due to moisture is not covered by actuator warranty.
- 4) Cycle damper with actuator once per year, a minimum of ten open/close cycles, to distribute grease in bearings and actuator.
- 5) Consult manufacturer if storage time exceeds two years.

## Installation Guidelines- Failure to follow instructions will void all warranties

---

The basic intent of a proper installation is to secure the heavy duty/industrial control damper into the opening in such a manner as to prevent distortion and disruption of damper operation. The following items will aid in completing the damper installation in a timely and effective manner.

- 1) Dampers are supplied standard without mounting holes. Drill or punch as required. If mounting holes are supplied, use appropriate gasketing between mating flanges. Closed cell sponge rubber, solid rubber, maximum 60 durometer, or fiberglass drop warp tape is recommended. If damper is replacing existing damper, clean mating surfaces prior to installing new damper.
- 2) Damper blades remain within the frame depth.
- 3) Damper may be installed with flow from either direction. Damper blade centerlines MUST be horizontal. Consult Greenheck for modifications if damper is to be mounted with blade centerlines vertical.
- 4) Isolate damper from high vibratory loadings.
- 5) If any NEMA electrical enclosure is supplied, use appropriate electrical connections so as to maintain the NEMA rating.

### DO'S

- 1) Use damper lifting lugs as provided.
- 2) Install all mounting bolts before tightening. Tighten in even and staggered pattern to evenly compress flange gasketing.
- 3) Mating flange must be flat and in the same plane.
- 4) Verify that damper does not strike mating ductwork or internal ductwork reinforcing when blade is in the open position.
- 5) Provide expansion joints upstream/downstream for angled ductwork so damper is not subjected to thermal/wind load forces off the centerline of damper.

### DON'TS

- 1) Do not lift damper with chain/strap with blade propped open and with chain/strap through frame as this could damage blade seal.
- 2) Do not use actuator, linkage, or axles as lifting point.
- 3) Do not use prybar to match frame holes to mating ductwork as frame can be warped or pulled out-of-round by excessive force.
- 4) Do not tighten mounting bolts by starting at one point and "walking" around the damper as uneven flange compression can result.

## Electrical Guidelines

---

Electrical and/or pneumatic connections to damper actuators should be made in accordance with wiring and piping diagrams developed in compliance with applicable codes, ordinances and regulations.

### **SAFETY CAUTION !**

**Verify power requirements before wiring actuator. Greenheck is not responsible for any damage to, or failure of the unit caused by incorrect field wiring.**

### **SAFETY DANGER !**

**Electrical input may be needed for this equipment. This work should be performed by a qualified electrician.**

# Damper Maintenance

Greenheck's dampers are designed to be trouble free and hassle free under normal operation. Dampers are to be installed square and straight so as to prevent binding during operation. The following annual damper maintenance suggestions will help to insure proper damper operation and increase the life expectancy of the damper.

**Foreign Matter**

Over the course of time, dirt and grime may collect on damper surfaces. The damper surfaces should be cleaned to prevent hindrance to airflow.

**Moving Parts**

Make sure that parts such as linkage, bearings, blades, etc. that are intended to move freely, can do so. Lubricating these components can prevent possible rusting and unnecessary friction increase. Use only a molybdenum spray oil or similar graphite based oil on sleeve bearings as regular lubricating oil will attract dirt.

*Bearings.* Synthetic, oil impregnated, carbon sleeve, and ball bearings (without grease fittings) do not require lubrication. Ball bearings with grease fittings should be lubricated as follows:

Maximum Duct Temperature		Lubricant	Minimum Frequency
°F	°C		
250	121	NLGI Grade 2 lithium 12-hydrostearate grease	twice a year
600	316	Hi temperature synthetic, Mobilith SHC100 or equal	four times a year

**Closure**

Remove foreign materials that may be interfering with blade closure or effective sealing of the blades with each other or with the frame.

*Blade Seals.* Inspect yearly and replace as necessary.

*Axle Seals.* Inspect and adjust as necessary.

**Operation**

While operating the damper through its full cycle, check to see that the blades open and close properly. If there is a problem, check for loose linkage, especially at the actuator. Tighten the linkage where required.

**Actuator**

Cycle test actuator per manufacturer's recommendations.

# Damper Trouble Shooting

The following is a cause and correction list for common concerns with the damper		
Problem	Possible Cause	Solution
Damper does not move	No power to actuator	Verify presence of correct power to actuator
	Actuator failed	Power actuator independently of damper
	Actuator attempting to rotate in wrong direction	Check wiring. Run actuator independent of damper if necessary.
	Linkage/coupling failed	Inspect coupling, keys, and connecting linkage for failed or broken components. Replace as required.
	No modulating signal	Verify presence of modulating signal. Verify signal is compatible with actuator. Verify if signal is driving actuator in the correct direction
	Damper linkage failed	Inspect damper for failed clevis pins, clevises, or crankarms and replace as necessary.
	Obstruction in damper linkage or inside duct	Inspect for projecting mounting bolts, debris inside damper and remove.

## Damper Trouble Shooting cont.....

The following is a cause and correction list for common concerns with the damper		
Problem	Possible Cause	Solution
Damper attempts to move but, does not open fully	Actuator sizing incorrect (excessive torque required)	Verify that correct operating pressures, velocities, and temperatures were given to manufacturer for actuator sizing. Replace actuator if necessary.
	Obstruction in damper linkage or inside duct	Inspect for projecting mounting bolts, debris inside damper and remove.
	Modulating control not going full span	Verify control signal span from controller
	Actuator linkage incorrectly adjusted	Power actuator, independently if necessary, to verify that is moving full stroke. Adjust actuator drive linkage or replace coupling spider if necessary.
	Damper with jamb seals installed with blades vertical	Consult factory, for modifications if vertical blade orientation not specified on damper with seals.
	Damper linkage modified in the field	Readjust linkage so blade rotates fully open and closed.
	Linkage pivots failed	Replace linkage bars, clevises and pins as required.
High noise level	Very high velocity/flow	Reduce flow through damper.
	No seals on dampers	Retrofit with blade edge and jamb seals.
	Damper not closing fully	Readjust actuator or drive linkage to fully close damper.
Excessive leakage across damper	Damper not closing fully	Readjust actuator or drive linkage to fully close damper.
	Damper not equipped with blade and jamb seals	Retrofit with blade edge and jamb seals.
	Blade edge seals failed	Replace blade edge seals.
	Stop angles not contacting blade edges	Close damper. Loosen fasteners and adjust stop angles so as to contact blade edge/blade seals.
	Caulking failed	Recaulk gaps with silicone sealant as required.
Excessive leakage through damper frame	No axle seals specified	Contact manufacturer for available modifications.
	O-ring axle seals worn	Replace o-rings as required.
	Double gland packing not tight	Tighten adjustment nuts on double gland stuffing box.
	Double gland packing worn	Replace packing as required.

### WARRANTY

Greenheck warrants this equipment to be free from defects in material and workmanship for a period of one year from the purchase date. Any units or parts which prove to be defective during the warranty period will be repaired or replaced at our option. Greenheck shall not be liable for damages resulting from misapplication or misuse of its products. Greenheck will not be responsible for any installation or removal costs. Greenheck will not be responsible for any service work or backcharges without prior written authorization.

