

Installation, Operation and Maintenance Manual

Please read and save these instructions for future reference. Read carefully before attempting to assemble, install, operate or maintain the product described. Protect yourself and others by observing all safety information. Failure to comply with instructions could result in personal injury and/or property damage!

Indoor Air Quality – VOC (Volatile Organic Compounds)

The Air Quality Controller – VOC is specifically designed to control a fan with a Vari-Green® motor. The controller senses the level of Volatile Organic Compounds (VOCs) in the space and automatically adjusts the ventilation rate to the space by increasing or decreasing the speed of the supply or exhaust fan based on the level of VOCs.

Applications for this controller include bathrooms, conference rooms, cafeterias, or any other space where air quality is of concern. Ventilating based on the VOC concentration assures that the space will not be over or under ventilated while using the Vari-Green motor technology to operate quietly and efficiently.

The VOC controller has adjustments for air quality setpoint, and minimum and maximum fan speed. The fan speed and VOC level are available as analog outputs to be read by a building automation system or a secondary device.

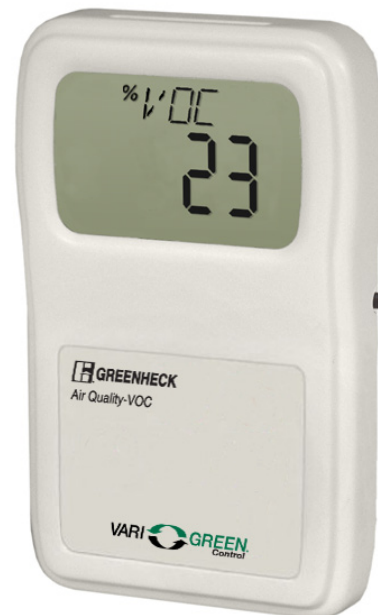

General Safety Information

Only qualified personnel should install this product. Personnel should have a clear understanding of these instructions and should be aware of general safety precautions. Improper installation can result in electric shock, possible injury due to coming in contact with moving parts, as well as other potential hazards. Other considerations may be required if high winds or seismic activity are present. If more information is needed, contact a licensed professional engineer before moving forward.

DANGER

Always disconnect, lock and tag power source before installing or servicing. Failure to disconnect power source can result in fire, shock or serious injury.

CAUTION

When servicing the fan, motor may be hot enough to cause pain or injury. Allow motor to cool before servicing.

CAUTION

Precaution should be taken in explosive atmospheres.

Electrical Safety Information

Follow all local electrical and safety codes, as well as the National Electrical Code (NEC) and the National Fire Protection Agency (NFPA). Where applicable, follow the Canadian Electric Code.

1. The rotation of the wheel is critical. It must be free to rotate without striking or rubbing any stationary objects.
2. Motor must be securely and adequately grounded.
3. Do not spin fan wheel faster than maximum cataloged fan RPM. Adjustment to fan speed significantly affects motor load. If fan RPM is changed, motor current should be checked to make sure it is not exceeding the motor nameplate amps.
4. Do not allow the power cable to kink or come in contact with oil, grease, hot surfaces, or chemicals. Replace cord immediately if damaged.
5. Verify that the power source is compatible with the equipment.
6. Never open access doors to a duct while the fan is running.

Receiving

Upon receiving the product check to make sure all items are accounted for by referencing the bill of lading to ensure all items were received. Inspect each crate for shipping damage before accepting delivery. Notify the carrier if any damage is noticed. The carrier will make notification on the delivery receipt acknowledging any damage to the product. All damage should be noted on all the copies of the bill of lading which is countersigned by the delivering carrier. A Carrier Inspection Report should be filled out by the carrier upon arrival and reported to the Traffic Department. If damaged upon arrival, file a claim with carrier. Any physical damage to the unit after acceptance is not the responsibility of Greenheck Fan Corporation.

Unpacking

Verify that all required parts and the correct quantity of each item have been received. If any items are missing, report shortages to your local representative to arrange for obtaining missing parts. Sometimes it is not possible that all items for the unit be shipped together due to availability of transportation and truck space. Confirmation of shipment(s) must be limited to only items on the bill of lading.

Electrical

The motor amperage and voltage ratings must be checked for compatibility to supply voltage prior to final electrical connection. Wiring must conform to local and national codes. Consult local code authorities for specific requirements.

Storage

Product is protected against damage during shipment. If the product cannot be installed and operated immediately, precautions need to be taken to prevent deterioration of the product during storage. The user assumes responsibility of the product and accessories while in storage. The manufacturer will not be responsible for damage during storage. These suggestions are provided solely as a convenience to the user.

Indoor Only

Do not store this product outdoors. The ideal environment for the storage of this product is indoors, above grade, in a low humidity atmosphere which is sealed to prevent the entry of blowing dust, rain or snow. Temperatures should be evenly maintained between 30° to 110°F (-1° to 43°C) (wide temperature swings may cause condensation and “sweating” of metal parts). All accessories must be stored indoors in a clean, dry atmosphere.

Remove any accumulations of dirt, water, ice, or snow and wipe dry before moving to indoor storage. Allow cold parts to reach room temperature to avoid “sweating” of metal parts. To dry parts and packages, use a portable electric heater to get rid of any moisture buildup. Leave coverings loose to permit air circulation and to allow for periodic inspection. The unit should not be stored on the floor.

Inspection and Maintenance During Storage

While in storage, inspect product once per month. Keep a record of inspection and maintenance performed. If moisture or dirt accumulations are found on parts, the source should be located and eliminated.

Installation and Setup Guide

This guide provides instructions for how to install, wire and program the control system for use when constant pressure in a duct or room system is required. This does not cover ductwork recommendations or other considerations.

Mounting

Mount the controller in the space to be controlled. Keep wire lengths between the controller and the fan to 200 feet or less.

Junction Box Mounting

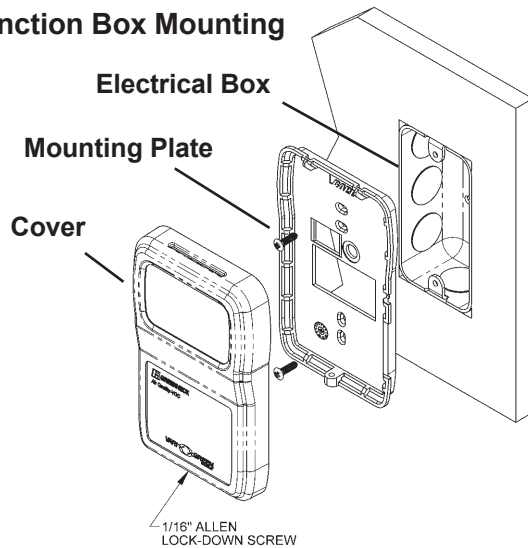

1. Separate the unit from the back plate by driving in the Allen screw until the two pieces come free.
2. Pull the wire through the wall and out of the junction box, leaving about six inches free.
3. Pull the wire through the hole in the base plate.
4. Secure the plate to the box using the #6-32 x 5/8 inch mounting screws provided.
5. Terminate the unit wiring.
6. Mold the foam on the unit's base to the wire bundle to prevent drafts. (see note below)
7. Attach Cover by latching it to the top of the base, rotating the cover down and snapping it into place.
8. Secure the cover by backing out the lock-down screw using a 1/16 inch Allen wrench until it is flush with the bottom of the cover.

Drywall Mounting

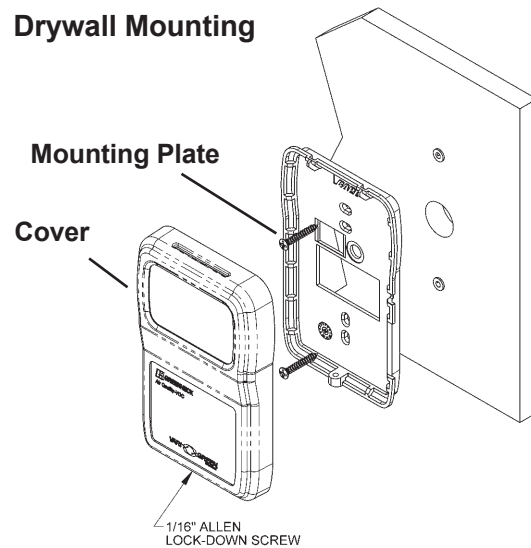

1. Separate the unit from the back plate by driving in the Allen screw until the two pieces come free.
2. Place the base plate against the wall where you want to mount the sensor.
3. Using a pencil mark out the two mounting holes and the area where the wires will come through the wall.
4. Drill two 3/16 inch holes in the center of each marked mounting hole, DO NOT punch the holes or the drywall anchors will not hold. Insert a drywall anchor into each hole.
5. Drill one 1/2 inch hole in the middle of the marked wiring area.
6. Pull the wire through the wall and out of the 1/2 Inch hole, leaving about six inches free.
7. Pull the wire through the hole in the base plate.
8. Secure the base to the drywall anchors using the #6 x 1 inch mounting screws provided.
9. Terminate the unit wiring.
10. Mold the foam on the unit's base to the wire bundle to prevent drafts. (see note below)
11. Attach cover by latching it to the top of the base, rotating the cover down and snapping it into place.
12. Secure the cover by backing out the lock-down screw using a 1/16 inch Allen wrench until it is flush with the bottom of the cover.

NOTE: In any wall-mount application, the air within the wall cavity can cause erroneous readings. The mixing of room air and air from within the wall cavity can lead to condensation, erroneous readings and sensor failure. To prevent these conditions, Greenheck recommends sealing the conduit leading to the junction box, filling the junction box with fiberglass insulation or sealing the wall cavity.

Wiring

All wiring for the Greenheck Air Quality Controller is Class II low-voltage control wiring. See the Wiring Diagram on Page 7 for the wiring overview.

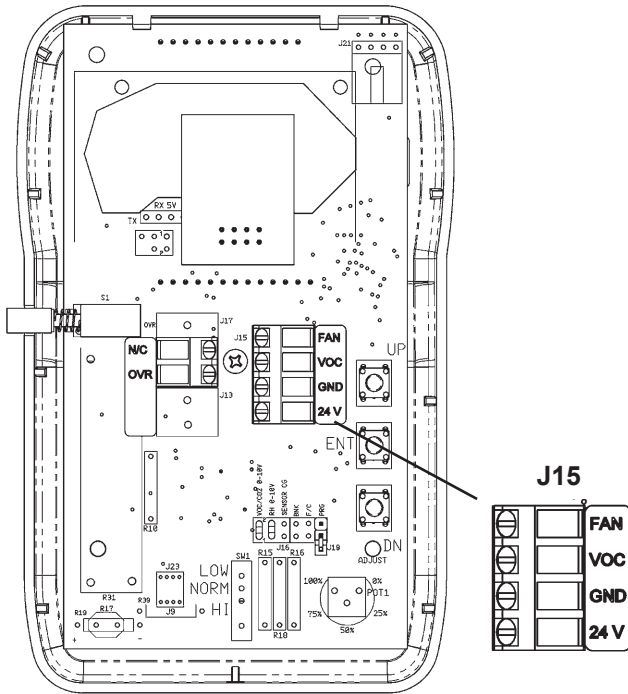

Control box to factory mounted transformer control input.

Controller Terminal	Transformer Control Terminal
J15-FAN	0 to 10V
J15-GND	COM
J15-24V	24V

Optional Remote Override

To add a Remote Override, connect a normally-open switch between terminals J17-OVR and J15-GND on the controller. (See Wiring Diagram on pg. 7.) Closing this switch will activate the Remote Override feature. Opening the switch will deactivate the override.

Optional VOC Level Output Reference

The VOC level is available an output signal of 0 to 10VDC from J15-VOC to J15-GND. (See Wiring Diagram on pg. 7.) The signal is the 0 to 100% VOC level.

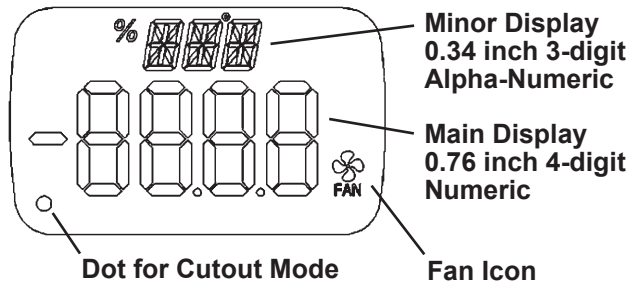

Display

On the front of the controller is a two-line display. The Minor Display describes the units or variable that is being displayed. The Main Display shows the numeric value. The Fan Icon is illuminated whenever the Fan Speed Output voltage is at or above the Output Minimum (as specified in parameter P7). The dot in the lower left is used to signal Fan Cutout Mode.

Normal Operation (J19 = RUN)

The Air Quality Controller ships from the factory set to control VOCs to 40% contamination – the display indicates the measured VOC Level (%VOC), the Fan Speed Output spans 2 to 10 Volts and the Fan Cutout Mode is disabled.

Scroll Button and Display Mode

The controller ships from the factory with the display set to indicate the measured VOC Level (%VOC). Pressing the scroll button at any time switches the display to the Air Quality Setpoint (%SET). A second push of the scroll button switches the display to the Fan Speed in percent (%SPD), and a third push returns the display to the VOC Level (%VOC).

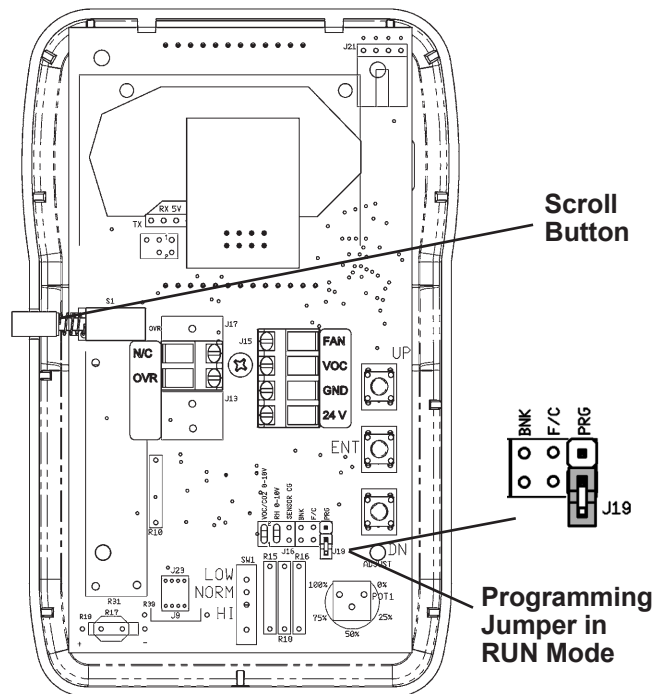

Programming (J19 = PRG)

The unit ships with factory default parameter setpoints. Parameter setpoints may be edited in the field by an HVAC technician. During parameter editing, the output voltage is set to zero.

General Programming

- Enter the edit mode by removing the unit from its base and placing jumper J19 on the PRG pins. The minor display will show the parameter name and the major display will show the parameter number.
- Press the UP or DN programming switch to select the parameter you wish to edit.
- Press the ENT program switch to select the parameter and enter the parameter edit mode. The minor display shall show the parameter name and the major display shall show the parameter value.
- Press the UP or DN programming switch to change the parameter value.
- Press the ENT program switch to store the parameter value and return to the parameter selection mode.
- Return to normal operation by placing the J19 jumper on a single pin.

Parameter Display	Description	Default Setting
<i>%SET</i> P0	Air Quality Setpoint	40%
<i>FAC</i> P1	Factory Defaults	0 (See Below)
<i>DIS</i> P2	Display Units	2 Air Quality in % VOCs
<i>CUT</i> P3	Fan Cutout Enable	0 Fan Cutout Disabled
<i>TIM</i> P4	Fan Cutout Timer	30 Seconds
<i>%OVR</i> P5	Output Override Percent	100%
<i>%SPD</i> P6	Output State	1 Automatic
<i>MIN</i> P7	Output Minimum	20%
<i>MAX</i> P8	Output Maximum	100%

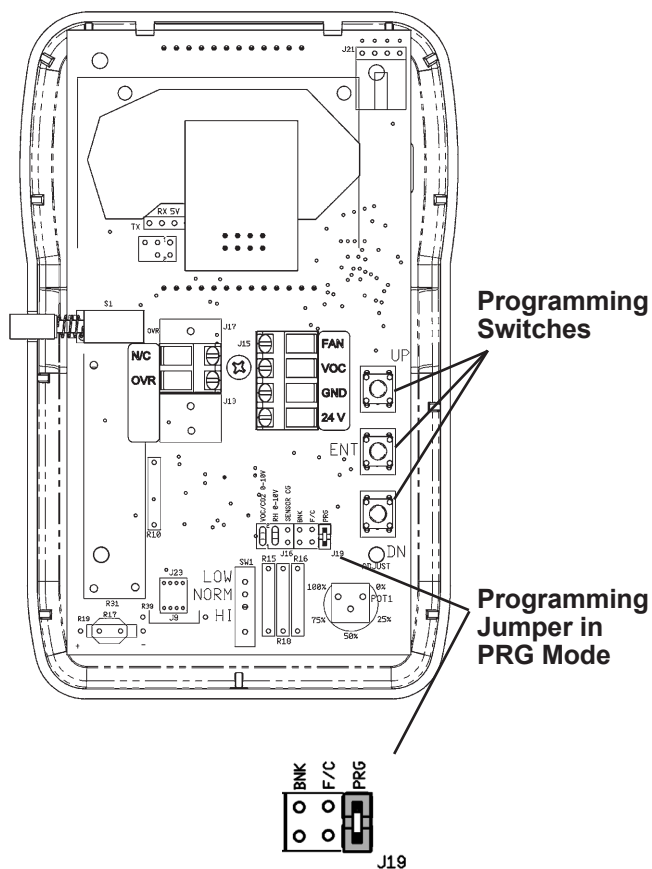

Parameter Descriptions

Air Quality Setpoint, Parameter P0

Factory Default = 40% VOC Level

Adjustable from 27 to 100% VOC Level in increments of 1%

Factory Defaults, Parameter P1

Factory Default = 0

0 = Entry Condition

1 = Set all parameters to the factory default setting

Display Units, Parameter P2

Factory Default = 2

0 – Display OFF

1 – Fan Speed Output in Percent

2 – Air Quality in % VOCs (Factory Default)

Note: If P2 is set to zero, the Dot and Fan Icon will still display normally, but the main and minor display will be off. If a Remote Override is used and the override switch is closed, the main and minor display will become active for as long as the contacts are closed. Pushing the scroll button will activate the main and minor for a few seconds.

Fan Cutout, Parameter P3

Factory Default = 0

0 – Fan Cutout Disabled

1 – Fan Cutout Enabled

The Fan Cutout is designed to shut off the exhaust fan when the VOC level falls below the Air Quality Setpoint.

With the Fan Cutout Enabled, when the %VOC measurement is 2% below the Air Quality Setpoint (as set by Parameter P0), the Fan Cutout timer is activated and the dot on the display will flash. After the Cutout Time has elapsed (as set by Parameter P4), the Fan Speed Output on the controller will go to 0 Volts, shutting off the exhaust fan. The Fan Icon on the display will extinguish and the Dot will be on steady.

When the %VOC measurement rises 5% above the Air Quality Setpoint, the controller leaves Fan Cutout mode and returns to normal operation. The Dot will extinguish and the Fan Icon will turn on.

Fan Cutout Timer, Parameter P4

Factory Default = 30 Seconds

0 to 300 seconds in 1 second increments

See Parameter P3 for operational details

Output Override Percent, Parameter P5

Factory Default = 100%

20% to 100% in 1% increments

During normal operation, when the remote override switch is closed, the Fan Speed Output on the controller will immediately ramp to the P5 Output Override Percent and stay there until the remote override switch is opened. The remote override can be activated by any normally-open voltage-free contact. (See Wiring Diagram on pg. 7.) Closing the contact will activate the override.

When the override is activated, the Fan Icon on the display will turn on and the minor display will show %OVR and the main display will show the Fan Speed Output percent value.

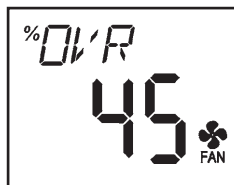

Output State, Parameter P6

Factory Default = 1

0 – Manual Control

1 – Normal Operation

The Output State allows manual control of the Fan Speed for system setup and commissioning tests. Exiting this parameter returns the controller to normal operation.

When entering this parameter, the value will be 1 (normal operation). Press the Down program switch to set the parameter value to 0 and then press the Enter program switch. The unit is now in Manual Control.

The major display will read 50 for 50% output (5 VDC output). The minor display will show %SPD.

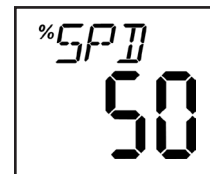

Pressing the Up program switch increases the displayed value and proportionally increases the Fan Speed Output from the controller. Pressing the Down program switch decreases the displayed value and proportionally decreases the Fan Speed Output.

The Fan Speed can be set to any value from 20% to 100% (for 2 to 10 VDC Fan Speed Output) or it can be set to 0 for 0 VDC Fan Speed Output.

The Fan Speed will remain at the displayed value until the Output State Parameter is returned to Normal Operation mode.

Output Minimum, Parameter P7

Factory Default = 20%

20 to 100% in 1% increments

Sets the controller's minimum Fan Speed Output level.

Note: the controller will not allow the output minimum to be set higher than the output maximum.

Output Maximum, Parameter P8

Factory Default = 100%

20 to 100% in 1% increments

Sets the controller's maximum Fan Speed Output level.

Note: the controller will not allow the output maximum to be set lower than the output minimum.

Wiring Diagram

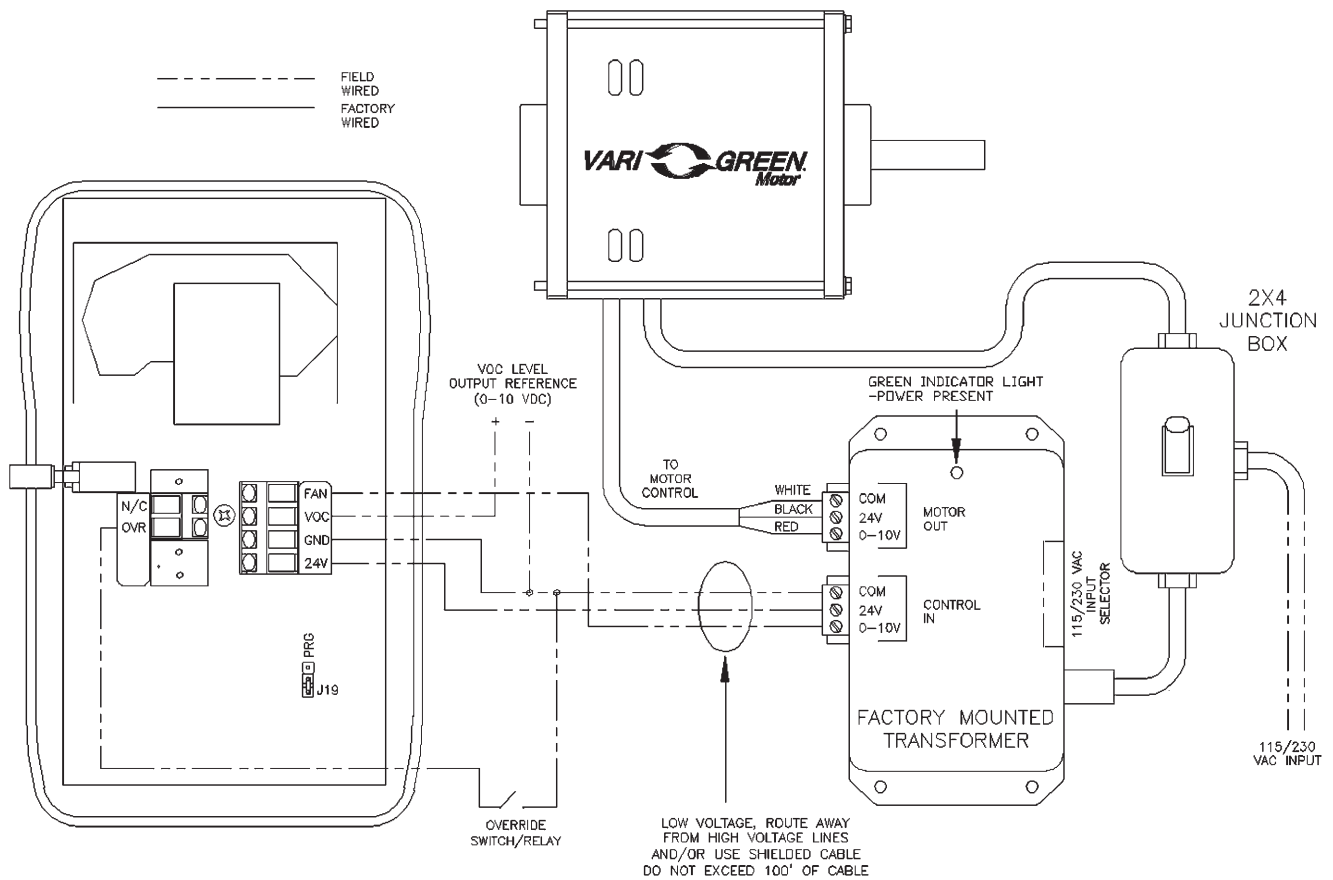

Troubleshooting

Problem	Potential Solution
Fan always at minimum speed	<ul style="list-style-type: none"> Place an opened permanent or white board marker underneath the controller. The fan should increase speed within a few minutes.
Fan always at high speed	<ul style="list-style-type: none"> Check that the air quality measurement is decreasing. If there is a large contamination it may take a while to exhaust the VOCs. Setpoint may be too low for persistent background VOCs. Check the space for a spill.
Fan Cutout not working properly	<ul style="list-style-type: none"> Setpoint may be too low for persistent background VOCs. If the controller will not turn the fan off, verify that the measured %VOC is at least 2% below set point. Verify that the cutout timer has started by looking for the flashing dot. If the controller will not restart the fan, verify that the measured %VOC is at least 5% above the setpoint.

Warranty

Greenheck warrants this equipment to be free from defects in material and workmanship for a period of one year from the shipment date. Any units or parts which prove defective during the warranty period will be replaced at our option when returned to our factory, transportation prepaid. Motors are warranted by the motor manufacturer for a period of one year. Should motors furnished by Greenheck prove defective during this period, they should be returned to the nearest authorized motor service station. Greenheck will not be responsible for any removal or installation costs.

As a result of our commitment to continuous improvement, Greenheck reserves the right to change specifications without notice.

Greenheck Vari-Green® Motor catalog provides additional information describing the equipment, fan performance, available accessories, and specification data.

AMCA Publication 410-96, Safety Practices for Users and Installers of Industrial and Commercial Fans, provides additional safety information. This publication can be obtained from AMCA International, Inc. at: www.amca.org.



Phone: (715) 359-6171 • Fax: (715) 355-2399 • E-mail: gfcinfo@greenheck.com • Web site: www.greenheck.com