



Part Number 475289

Field Installation Instructions for Extension Pin, Extension Pin Kit & Manual Quadrant Operators on VCD-40 Dampers

NOTE: FOR DAMPERS INSTALLED IN DUCTS

Extended Control Shaft is installed from outside of duct after damper is installed. Install as shown below.

TOOLS REQUIRED:
 5/16 in. Hex Nut Driver
 3/8 in. Electric Drill
 1/2 in. Open End Wrench

Part Number 846031 Extension Pin with Clip			
No.	Qty	Description	Part Number
1	1	Extended Control Shaft	452509
2	1	Retaining Clip	451738

Part Number 865083 1/2 in. Extension Pin Kit			
No.	Qty	Description	Part Number
1	1	Standoff Brackets	864190
2	1	Extension Pin	452509
3	1	Retaining Clip	451738
4	3	1/4-20 Nut	451738
5	3	14-20 x 1/2 in. Stud	415609

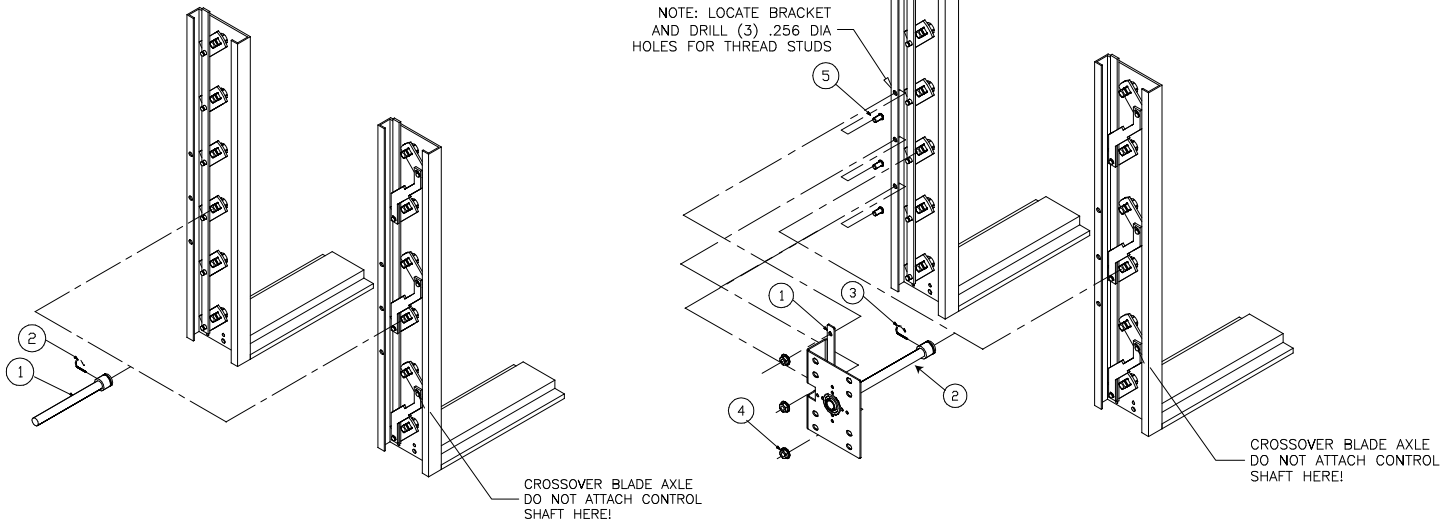

Before Installing Damper in the Duct

1. If damper has more than one blade, determine which blade axle will be driven by the extended control shaft. Always attach extended control shaft to a blade axle which is directly connected to the main linkage tiebar. **DO NOT** attach extended control shaft to a crossover blade axle.
2. Cut hole approximately 1 in. (25mm) diameter in duct where damper drive blade axle will be located. Hole must provide clearance for enlarged portion of extended control shaft.

After Damper Is Installed in Duct

1. Push extended control shaft through hole in duct and onto drive blade axle. Retainer clip should "click" into groove on drive blade axle and hold shaft into place.
 Standard Control Shaft location is the third blade from the bottom on dampers with three or more blades. Control Shaft location is the first blade from the bottom on dampers with one or two blades.

Before Installing Damper in the Duct

1. If damper has more than one blade, determine which blade axle will be driven by the extended control shaft. Always attach extended control shaft to a blade axle which is directly connected to the main linkage tiebar. **DO NOT** attach extended control shaft to a crossover blade axle.
2. Cut hole approximately 1 in. (25mm) diameter in duct where damper drive blade axle will be located. Hole must provide clearance for enlarged portion of extended control shaft.

After Damper Is Installed in Duct

1. Push extended control shaft through hole in duct and onto drive blade axle. Retainer clip should "click" into groove on drive blade axle and hold shaft into place. Standard Control Shaft location is the third blade from the bottom on dampers with three or more blades. Control Shaft location is the first blade from the bottom on dampers with one or two blades.
2. Install the stand off bracket with bearing over the extended control shaft and screw bracket to duct. Make sure screws (provided by others) do not interfere with damper linkage or blade movement.

Caution: Stand off bracket with bearing is needed to support the extended control shaft. If not installed as directed, the extended control shaft may not operate the damper correctly.

Part Number 865085 1/2 in. Extension Pin Kit with Manual Quadrant			
No.	Qty	Description	Part Number
1	1	Extension Pin Kit	809735
2	2	#10 x 1/2 in. Self Drilling SMS	415555
3	1	1/2 in. dia. Manual Quadrant	455648
4	1	OPEN & CLOSED Labels	452690
5	1	Washer (included with No. 3)	

Part Number 813938 1 in. Manual Quadrant Kit			
No.	Qty	Description	Part Number
1	1	1 in. Quadrant Bracket	649366
2	1	Quadrant Lever Arm Assembly	814406
3	1	3/8 -16 Spinlock Nut ZP	415457
4	1	3/8 -16 x 2.5 in. Carriage Bolt	415485
5	1	3/8 -16 x 1 in. Short shank Carriage Bolt	415820
6	1	3/8 -16 Wing Nut	415821
7	4	1/4 -20 1/2 in. Self Threading Screw	415264
8	1	Label - Open/Close	452690
9	1	5/8 in. Flat Washer	415381

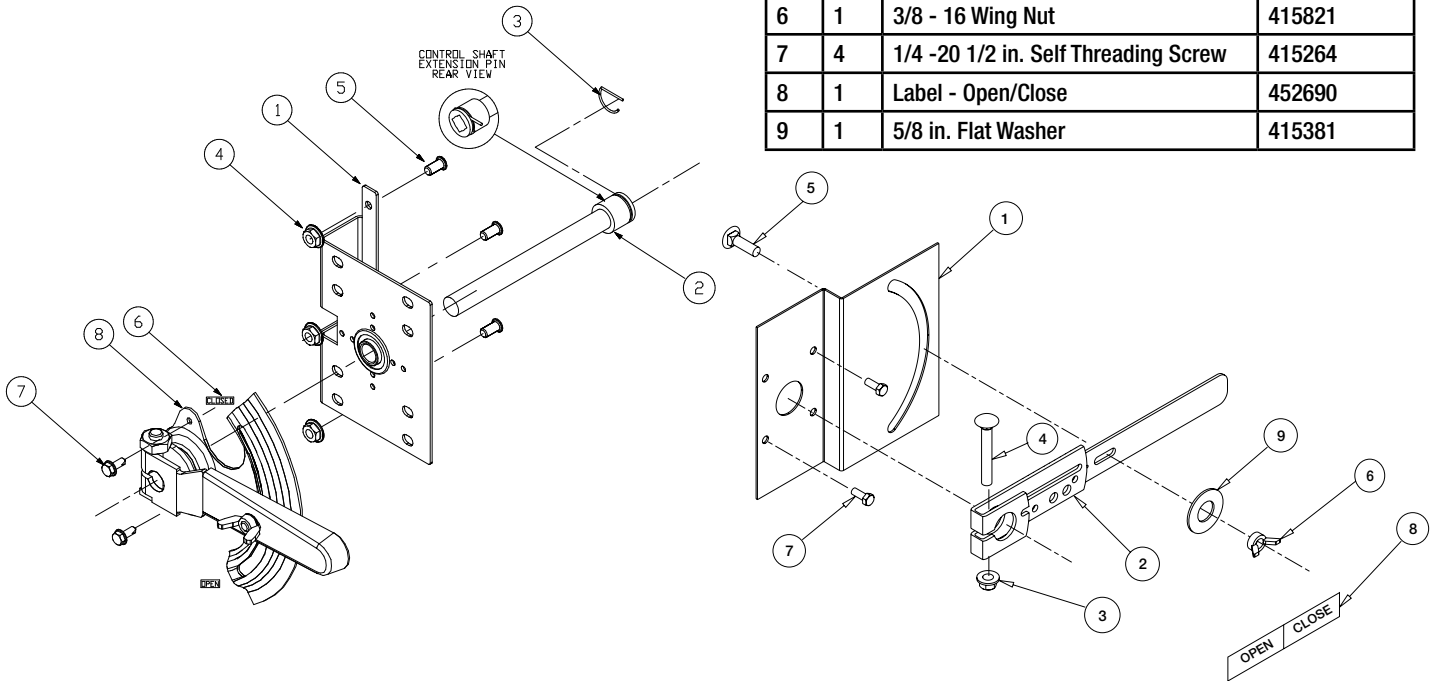

Non-Jackshafted Dampers

Control damper should be mounted in the duct and the shaft extension mounted onto the correct blade of the damper before continuing with these instructions.

After Extended Shaft is Installed

1. Assemble Manual Quadrant to extension bracket assembly (screws provided).
2. With damper either fully open or closed, lock manual quadrant to extended control shaft so manual quadrant can move damper between open and closed. Note: Tighten down bolt on manual quadrant to 250 in. lb. of torque. Apply "OPEN" and "CLOSED" labels if damper movement is opposite to that engraved in the manual quadrant.
3. Set damper to desired position and tighten wing nut on manual quadrant to hold damper in place.

Jackshafted Dampers

1. The jackshaft is, either, 1/2 in. diameter or 1 in. diameter depending upon the size of the damper. The manual quadrant kit for the 1/2 in. diameter jackshaft is Part #865085 and the manual quadrant kit for a 1 in. diameter jackshaft is Part #813938.
2. With damper either fully open or closed, lock manual quadrant to jackshaft so manual quadrant can move damper between open and closed. Note: Tighten down bolt on manual quadrant to 250 in. lb. of torque. Apply "OPEN" and "CLOSED" labels if damper movement is opposite to that engraved in the manual quadrant.
3. Set damper to desired position and tighten wing nut on manual quadrant to hold damper in place.

