

Installation Instructions

These instructions apply to the internal field replacement of the Siemens Series actuators on Greenheck VCD control damper models.

Tools Required:
Wrenches: (1) 1/2 in., (1) 7/16 in.,
(1) 3/8 in., (1) 10 mm

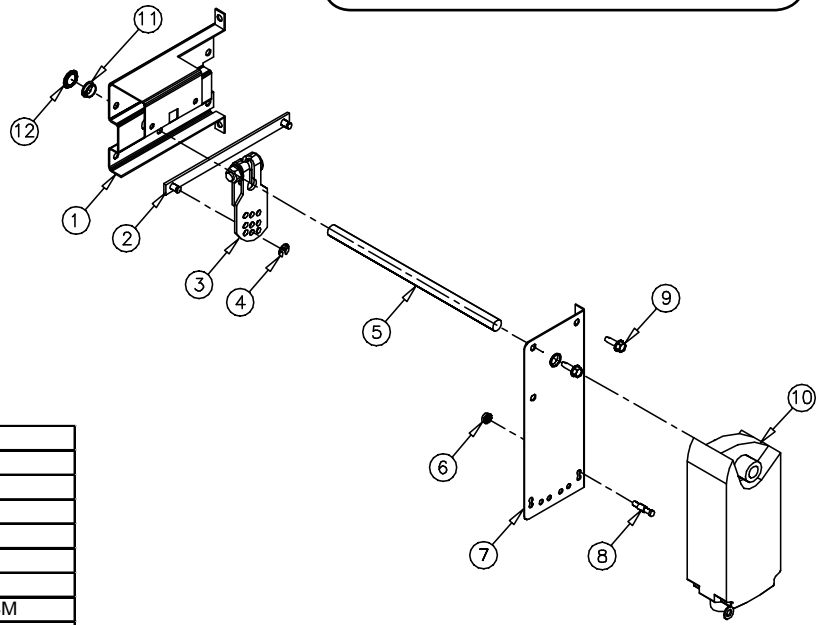

ACTUATOR	PART #
GND121.1U 24V	383774
GND126.1U 120V	383775
GND221.1U 120V	383776
GND226.1U 120V	383777
GND321.1U 230V	383778
GND362.1U 120V	383779

ITEM #	QTY	PART #	DESCRIPTION
1	1	723981	INTERNAL ACTUATOR BRKT
2	1	839475	DRIVE LINK ASSEMBLY
3	1	829206	1/2" CRANKARM ASSEMBLY
4	1	451588	1/4" E-RING
5	1	593831	6.5" JACKSHAFT, 1/2" DIA.
6	1	415385	10-32 KEPS NUT
7	1	846591	1/2" ANTI-ROTATION BRKT. ASM
8	1	416122	THREADED MOUNTING STUD
9	2	415264	1/4-20x1/2 TCS
10	1	SEE CHART	ACTUATOR
11	1	370159	1/2" SNAP IN BEARING
12	1	416179	RETAINING RING 1/2"

Figure 1: Siemens Series internal mount (exploded view).

⚠ WARNING
Equipment Damage or Electrical Power Hazard. Line voltage can cause death or serious injury and short equipment circuitry. Disconnect power supply before installation.

⚠ CAUTION
Device Malfunction Hazard. Improper set screw tightening causes device malfunction. Tighten set screws with proper torque to prevent damper shaft slippage.

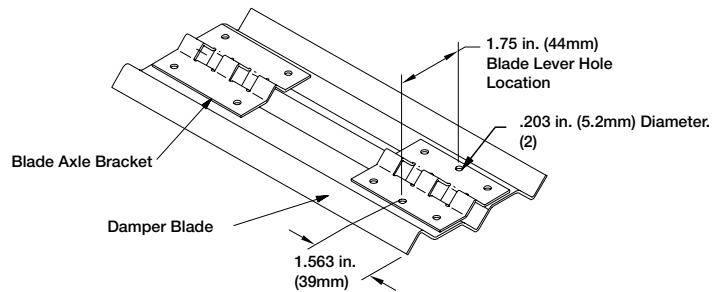

Detail A

Instructions

Siemens GND Series

These installation instructions assume a damper is already mounted in a duct or sleeve. Have damper blades in the fail position.

1. Drill (2) .203 inch holes in the third blade from bottom, at location shown in *Detail A*.
2. Attach blade drive lever to blades using (2) 1/4" 20 x 1/2" thread cutting screws, self drilling screws or 1/4" - 20 x 1 1/4" bolts.
3. Fasten internal actuator bracket (item 1) to the left jamb of damper frame using (2) thread cutting screws. Snap bearing (item 11) into the internal actuator bracket (item 1).
4. Snap bearing (item 11) into the anti-rotation bracket (item 7) and attach to the internal mount bracket (item 1) using [2] thread cutting screws (item 9).
5. Slide 1/2" diameter rod (item 5) slightly through the anti rotation bracket (item 7). Install crankarm (item 3) and drive link (item 2) onto the 1/2" diameter rod and (item 5) and install retaining ring (item 12) to lock drive link onto the internal actuator bracket (item 1).
6. Install threaded mounted stud (item 8) to the anti rotation bracket (item 7) using #10-32 Keps nut (item 6).
7. Attach actuator (item 10) to the anti-rotation bracket assembly (item 7). Tighten actuator onto shaft.
8. Connect drive link to blade drive lever using e-clip. With blades closed and the actuator in its fail position, position blades in their fail position and tighten the crankarm to the 1/2 in. shaft.
9. Connect all electrical leads to the actuator. Apply power to the actuator. The damper blades should power position and return to the fail position when power is disconnected.

Model	Volts	Running	Holding
GND121.1	24	0W	0W
GND126.1	24		
GND221.1	120	0	0
GND226.1	120		
GND321.1	230V	0	0
GND326.1	230V		

