

These instructions apply to the external field installation of Belimo actuators on Greenheck model VCD Control Dampers when they are duct mounted or sleeved. For severe environment actuator kits, reference page 3 & 4.

Tools Required:
Wrenches:
(1) 3/8 in., (1) 7/16 in., and (1) 10mm

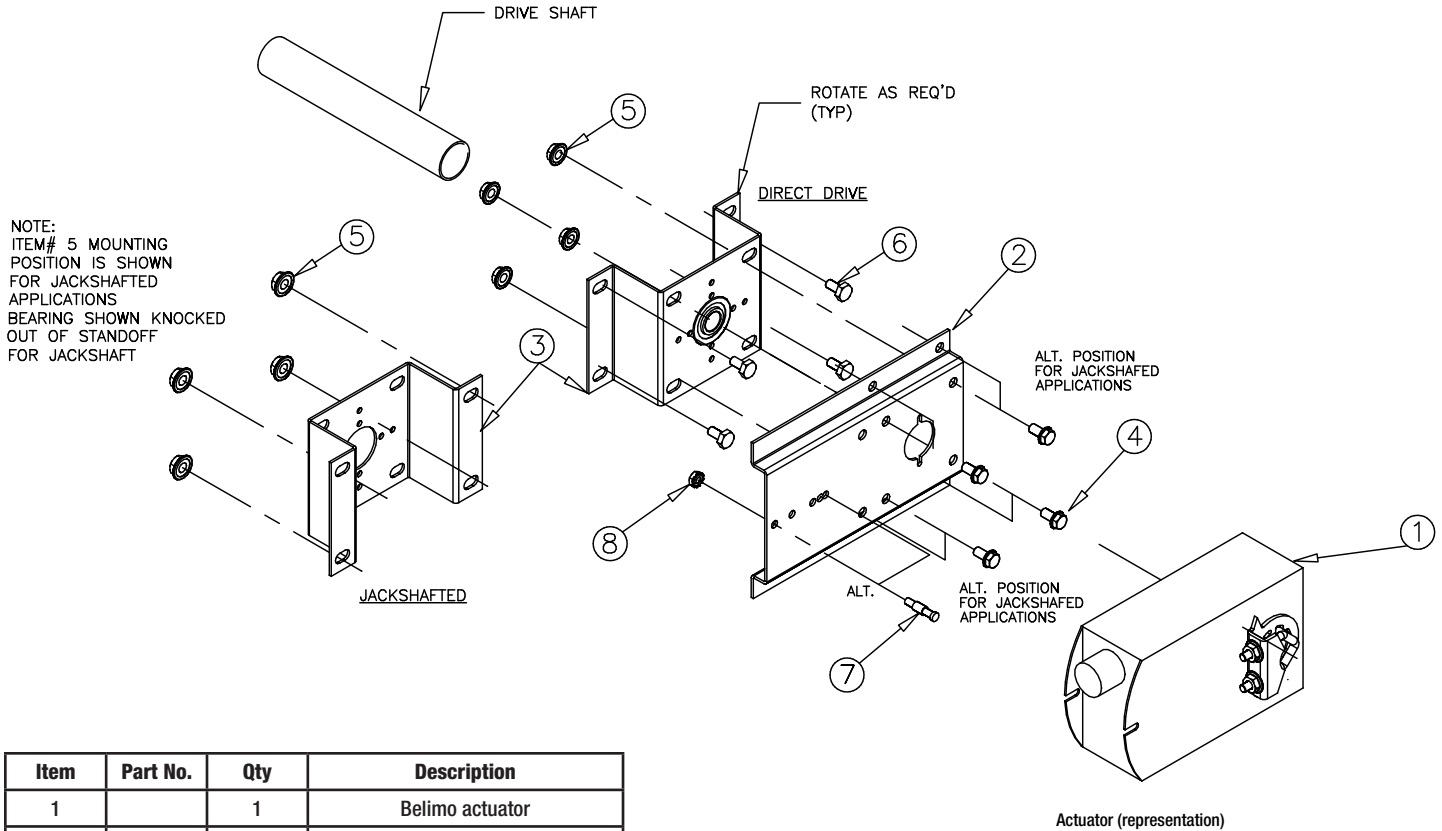

| Item | Part No. | Qty | Description |
|------|----------|-----|-----------------------|
| 1 | | 1 | Belimo actuator |
| 2 | 723092 | 1 | Anti-rotation bracket |
| 3 | 815027 | 1 | Standoff bracket |
| 4 | 415475 | 4 | 1/4 -20 x 1/2" bolt |
| 5 | 415455 | 4 | 1/4-20 spinlock nut |
| 6 | 415586 | 4 | #14 TEK screw |
| 7 | 416122 | 1 | Anti-rotation pin |
| 8 | 415385 | 1 | Keps hex nut zp. |

⚠ WARNING
Equipment Damage or Electrical Power Hazard. Line voltage can cause death or serious injury and short equipment circuitry. Disconnect power supply before installation.

⚠ CAUTION
Device Malfunction Hazard. Improper set screw tightening causes device malfunction. Tighten set screws with proper torque to prevent damper shaft slippage.

Instructions:

These installation instructions assume the damper is already mounted in a duct or sleeve with the damper shaft extending beyond the duct or sleeve 6 inches (152mm).

1. Install the stand off bracket.

Dampers with a jackshaft

- 1a. Mount the stand off bracket (item 3) onto the jackshaft bracket with [4] 1/4 - 20 x 1/2 in. bolts (item 4) and [4] 1/4 - 20 spinlock nut (item 5) Orient the anchor bracket perpendicular to the damper on the duct or sleeve so that the bracket shaft hole is centered on the jackshaft.

Dampers without a jackshaft (Shaft Extension)

- 1b. Mount the stand off bracket (item 3) and extension pin, as detailed in extension pin kit instructions, spanning across the damper frame flanges. Orient the anchor bracket perpendicular to the damper on the duct or sleeve so that the bracket shaft hole is centered on the shaft extension. Fasten to the damper frame with (4) #14 Tek screws or equal (item 6), supplied by others. Be sure not to run the screws into the damper linkage, which is between the flanges.

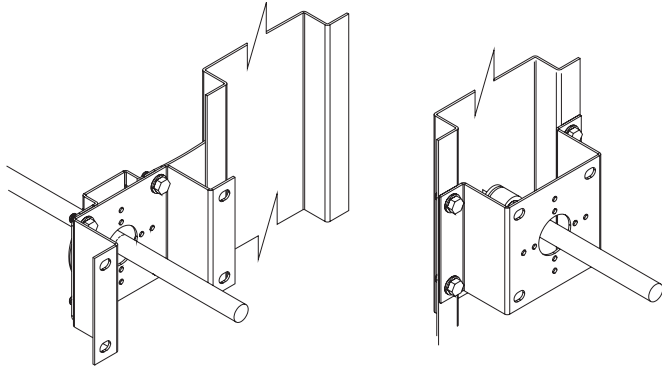

Orientation of Stand Off Bracket for a jackshaft driven damper

Orientation of Stand Off Bracket for a directly driven damper

2. If the fail rotation of the damper is counter clockwise, this is a Left Hand installation and the universal clamp should be on the side labeled CCW on the actuator (usually shipped in this orientation). If the fail rotation of the damper is clockwise, this is a Right Hand installation and the universal clamp should be on the side labeled CW on the actuator.

To change the universal clamp from one side to the other side, remove the retaining clamp and then the universal clamp from the actuator. Replace the universal clamp on the correct side of the actuator making sure that the corresponding tab is pointing to 0° and fits onto the actuator. Slip the clamp on and then lock in place using the retaining clamp.

Note: All fail rotations refer to the damper shaft rotation needed to achieve the desired blade fail position. If fail position is closed, make sure damper blades are fully close and ensure blade seals are compressed prior to tightening the actuator clamp to the damper extension pin or jackshaft. Inspect the damper blades and the damper shaft to determine the proper damper shaft rotation for the desired blade fail position.

3. Slide the actuator and the mounting bracket (item 2) onto the damper shaft. Mount the mounting bracket (item 2) to the stand off bracket (item 3) using (4) 1/4 in.-20 x 1/2 in. bolts (item 4), and (4) 1/4 in. - 20 Spinlock nuts (item 5). Use the outer four holes of the mounting bracket for jackshafted models and the inner four holes for directly driven models.

Note: The mounting bracket (item 2) may be attached in three positions: parallel with the duct, perpendicular up from the duct, or perpendicular down from the duct. Choose a position that offers the most clearance for the application.

4. Verify that the damper is in its fail position. Tighten the universal clamp to the damper shaft.
5. The wiring illustration is located on the face of the actuator. Wiring should be per an approved project or job wiring diagram and must comply with all applicable electrical codes.
6. Apply power to the actuator. The damper blades should fully open or close. No adjustments are required.

| Model | Volts | Running | Holding |
|-----------|-------|---------|---------|
| AMB24-3 | 24 | 2.5W | 2.5W |
| AMB24-SR | 24 | | |
| FSLF24 | 24 | 5VA | 3.5VA |
| FSLF24-S | 24 | | |
| FSLF120 | 120 | 18VA | 6.5VA |
| FSLF120-S | 120 | | |
| FSLF230 | 230 | 17VA | 6VA |
| FSLF230-S | 230 | | |
| LF24-SR | 24 | 2.5W | 1W |
| LF24-SR-S | 24 | | |
| LMB24-3 | 24 | 1.5W | 1.5W |
| LMB24-3-S | 24 | | |
| LMB24-SR | 24 | | |
| NMB24 | 24 | 2W | 2W |
| NMB24-SR | 24 | 2.5W | 2.5W |
| TF24 | 24 | 2W | 1.3W |
| TF24-S | 24 | | |
| TF120 | 120 | 2.5W | 1.3W |
| TF120-S | 120 | | |
| TF24-SR | 24 | 2W | 1W |
| TF24-SR-S | 24 | | |

Severe Environment (316SS)

These instructions apply to the external field installation of Belimo actuators on Greenheck model SEVCD Control Dampers when they are duct mounted or sleeved

Tools Required:
Wrenches:
 (1) 3/8 in., (1) 7/16 in., and (1) 10mm

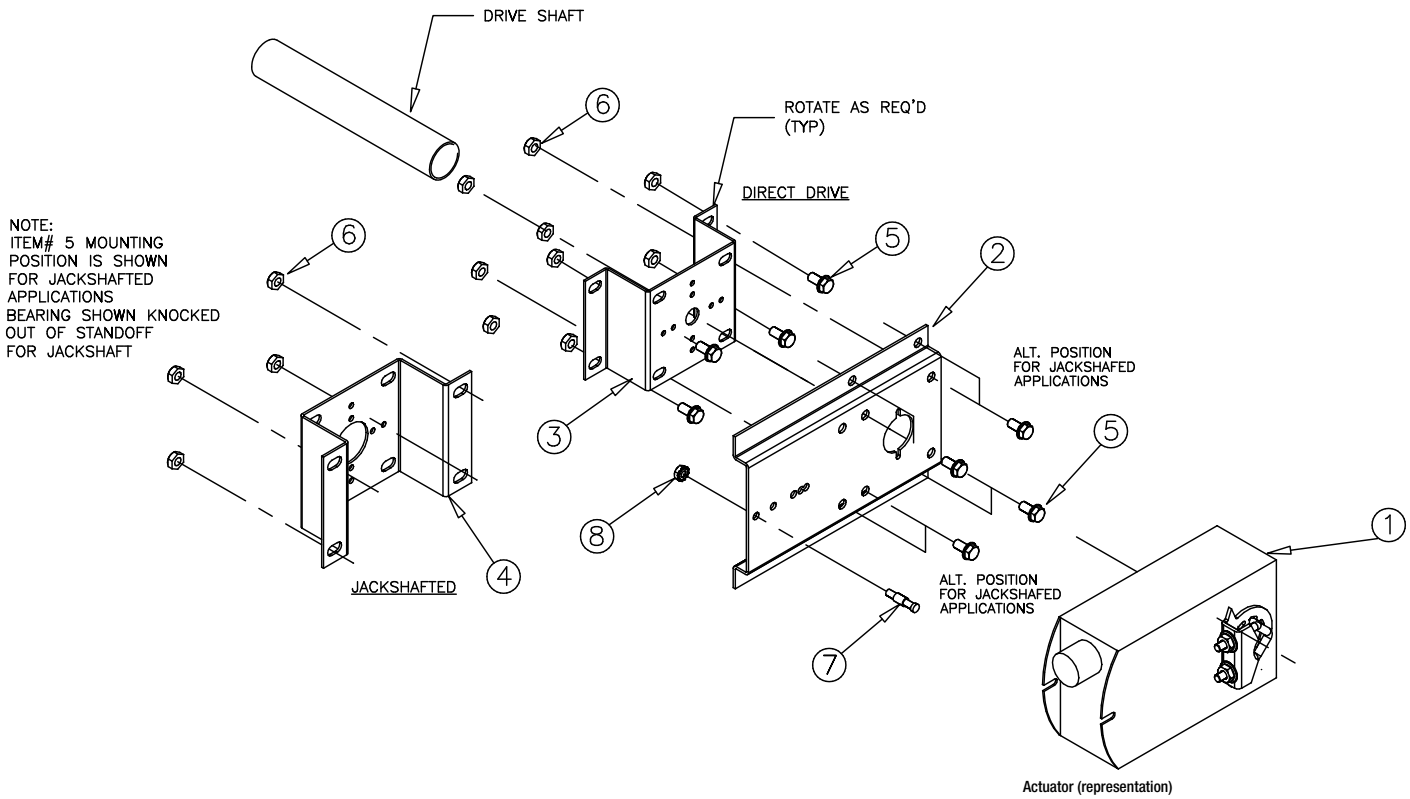

| Item | Part No. | Qty | Description |
|------|----------|-----|--|
| 1 | | 1 | Belimo actuator |
| 2 | 689990 | 1 | Anti-rotation bracket 316SS |
| 3 | 687784 | 1 | Standoff bracket non-jackshafted units 316SS |
| 4 | 687405 | 1 | Standoff bracket jackshaft units 316SS |
| 5 | 415475 | 8 | CS 1/4-20 x 1/2" bolt 316SS |
| 6 | 415702 | 8 | 1/4-20 hex nut 316SS |
| 7 | 463888 | 1 | Belimo mounting stud 316SS |
| 8 | 415702 | 1 | #10-32 SS nut |



WARNING

Equipment Damage or Electrical Power Hazard. Line voltage can cause death or serious injury and short equipment circuitry. Disconnect power supply before installation.



CAUTION

Device Malfunction Hazard. Improper set screw tightening causes device malfunction. Tighten set screws with proper torque to prevent damper shaft slippage.

Instructions for Severe Environment (316SS):

These installation instructions assume the damper is already mounted in a duct or sleeve with the damper shaft extending beyond the duct or sleeve 6 inches (152mm).

1. Install the stand off bracket.

Dampers with a jackshaft

- 1a. Mount the stand off bracket (item 4) onto the jackshaft bracket with (4) 1/4-20 x 1/2 in. stainless steel bolts (item 5) and 1/4-20 hex nuts (item 6). Orient the anchor bracket perpendicular to the damper on the duct or sleeve so that the bracket shaft hole is centered on the jackshaft.

Dampers without a jackshaft (Shaft Extension)

- 1b. Mount the stand off bracket (item 3) and extension pin, as detailed in extension pin kit instructions, spanning across the damper frame flanges. Orient the anchor bracket perpendicular to the damper on the duct or sleeve so that the bracket shaft hole is centered on the shaft extension. Fasten to the damper frame with (4) 1/4-20 x 1/2 in. stainless steel bolts (item 5) and 1/4-20 hex nuts (item 6). Be sure not to run the screws into the damper linkage, which is between the flanges.

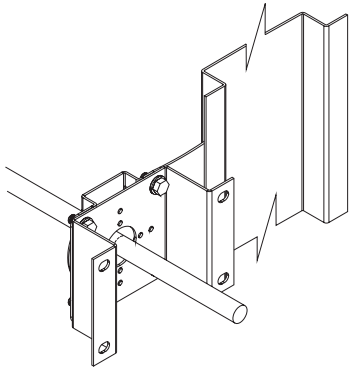

Orientation of Stand Off Bracket for a jackshaft driven damper

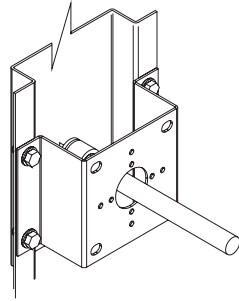

Orientation of Stand Off Bracket for a directly driven damper

2. If the fail rotation of the damper is counter clockwise, this is a Left Hand installation and the universal clamp should be on the side labeled CCW on the actuator (usually shipped in this orientation). If the fail rotation of the damper is clockwise, this is a Right Hand installation and the universal clamp should be on the side labeled CW on the actuator.

To change the universal clamp from one side to the other side, remove the retaining clamp and then the universal clamp from the actuator. Replace the universal clamp on the correct side of the actuator making sure that the corresponding tab is pointing to 0° and fits onto the actuator. Slip the clamp on and then lock in place using the retaining clamp.

Note: All fail rotations refer to the damper shaft rotation needed to achieve the desired blade fail position. If fail position is closed, make sure damper blades are fully closed and ensure blade seals are compressed prior to tightening the actuator clamp to the damper extension pin or jackshaft. Inspect the damper blades and the damper shaft to determine the proper damper shaft rotation for the desired blade fail position.

3. Slide the actuator and the mounting bracket (item 2) onto the damper shaft. Mount the mounting bracket (item 2) to the stand off bracket using (4) 1/4 in.-20 x 1/2 in. bolts (item 5), and (4) 1/4 in. - 20 Spinlock nuts (item 6). Use the outer four holes of the mounting bracket for jackshafted models and the inner four holes for directly driven models.

Note: The mounting bracket (item 2) may be attached in three positions: parallel with the duct, perpendicular up from the duct, or perpendicular down from the duct. Choose a position that offers the most clearance for the application.

4. Verify that the damper is in its fail position. Tighten the universal clamp to the damper shaft.
5. The wiring illustration is located on the face of the actuator. Wiring should be per an approved project or job wiring diagram and must comply with all applicable electrical codes.
6. Apply power to the actuator. The damper blades should fully open or close. No adjustments are required.

