

Centrifugal Fan Isolation Base Assembly Instructions

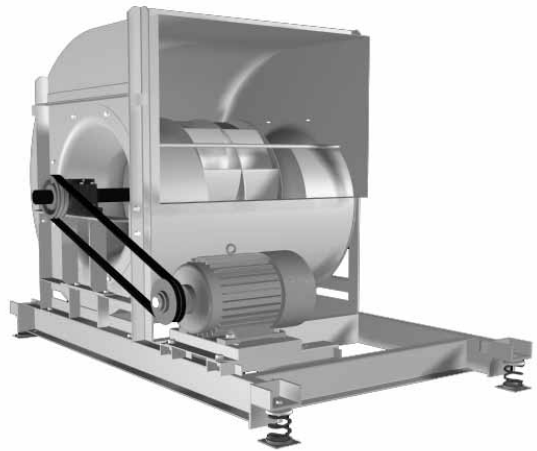
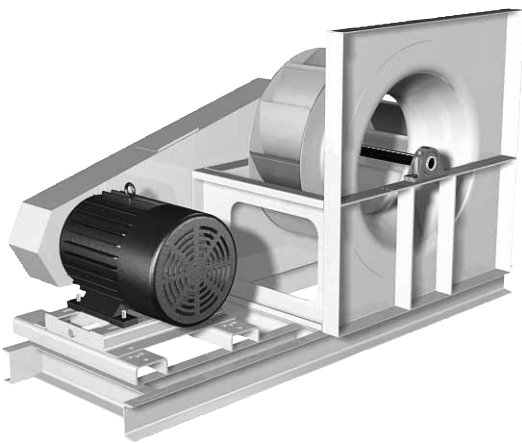
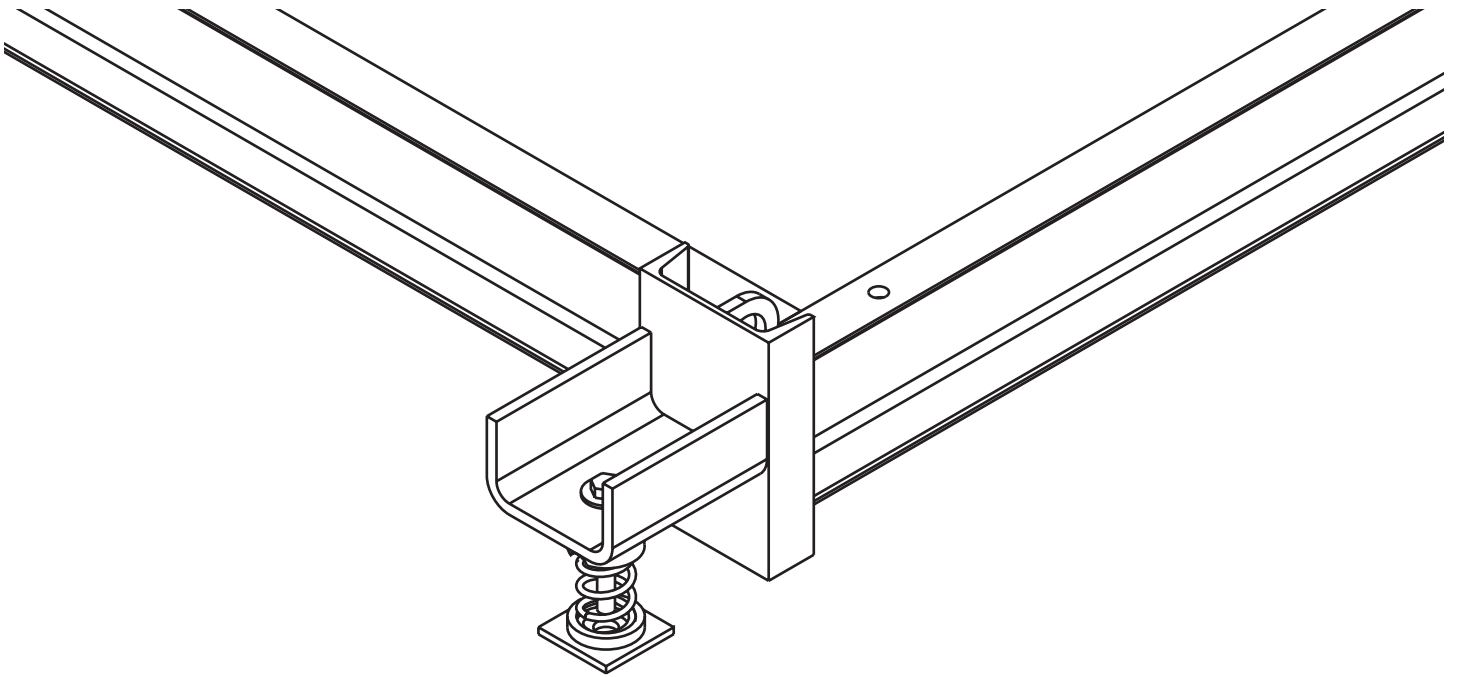

For use with the following Greenheck Models

BISW, AFSW, BIDW, AFDW, QEP, IPA, IPO and IPW

Base Fasteners

A Fastener Kit is enclosed with your fan unit. Assorted fasteners will be used to attach the isolation base to the fan frame. Note that this kit contains fasteners used for multiple fan sizes. There will be leftover fasteners that can be discarded. A diagram of the hardware assembly sequence can be found on the next page.

One of three kits will ship with the unit dependent on the model and size of the fan. Refer to the Fastener Kit Parts List to ensure the appropriate kit was shipped and that it includes the correct pieces. If the fan uses Kit #2 or #3, use the largest bolt that will fit through the base channel and fan framework along with the appropriate washers and nuts, the others may be discarded. GFC part numbers 818034, 818035 and 818036 are the stainless steel versions of these kits.

Fastener Kit Parts List #1 GFC Part #818031 or #818034 (SS)	
Quantity	Description
6	3/8 Bevel Washer
6	3/8-16 x 2.25 HH Bolt (2.00 = SS)
6	3/8-16 Hex Nut
12	3/8 Flat Washer
6	3/8 Lock Washer

Fans that use Kit #1	Arrangement	Class
Single Width 12-18	1, 9	Class III
Single Width 12-16	3	Class I, II, III
Double Width 12-16	3	Class I, II, III
Plenum 12-16	3	Class I, II, III

Fastener Kit Parts List #2 GFC Part #818032 or #818035 (SS)	
Quantity	Description
6	3/8 Bevel Washer
6	3/8-16 x 2.25 HH Bolt (2.00 = SS)
6	3/8-16 Hex Nut
12	3/8 Flat Washer
6	3/8 Lock Washer
6	1/2 Bevel Washer
6	1/2-13 x 2.50 HH Bolt (2.00 = SS)
6	1/2-13 Hex Nut
12	1/2 Flat Washer
6	1/2 Lock Washer

Fans that use Kit #2	Arrangement	Class
Single Width 7-33	1, 9, 10	Class I, II
Single Width 20-33	1, 9	Class III
Single Width 18-36	3	Class I, II, III
Double Width 18-36	3	Class I, II, III
Plenum 18-36	3	Class I, II, III
Industrial 5-19	1, 9, 10	SD, HD

Fastener Kit Parts List #3 GFC Part #818033 or #818036 (SS)	
Quantity	Description
6	1/2 Bevel Washer
6	1/2-13 x 2.50 HH Bolt (2.00 = SS)
6	1/2-13 Hex Nut
12	1/2 Flat Washer
6	1/2 Lock Washer
6	5/8 Bevel Washer
6	5/8-11 x 2.25 HH Bolt (3.00 = SS)
6	5/8-11 Hex Nut
12	5/8 Flat Washer
6	5/8 Lock Washer

Fans that use Kit #3	Arrangement	Class
Single Width 36-73	1, 9, 10	Class I, II, III
Single Width 40-73	3	Class I, II, III
Double Width 40-43	3	Class I, II, III
Plenum 40-73	3	Class I, II, III
Industrial 21-41	1, 9	SD, HD

All dimensions shown are in inches.

Single Width refers to GFC fan models AFSW, BISW

Double Width refers to GFC fan models AFDW, BIDW

Plenum refers to GFC fan model QEP

Industrial refers to GFC fan models IPA/IPO/IPW

Installation Instruction for Isolation Base Fastener Kit

Align the holes in the Fan Mounting Angle of the assembled fan with the holes in the Isolation Base. Utilize the largest bolt possible along with the appropriate washers and nuts. Place the correct flat washer on the provided SAE Grade 5 bolt followed by the matching sized bevel washer. Insert the bolt/washer assembly through the bottom of the hole in the Isolation Base and Fan Mounting Angle. Be sure the bevel washer is aligned properly so the bolt protrudes from the hole perpendicular to the Fan Mounting Angle. Next, place the other flat washer of the same size on the bolt followed by the lock-washer of the same size. Fasten the assembly with the matching size hex nut. Install and hand-tighten all hardware assemblies to ensure proper alignment, then torque each to their specified value as follows:

- 3/8 inch bolt – 25 ft-lbs
- 1/2 inch bolt – 100 ft-lbs
- 5/8 inch bolt – 130 ft-lbs

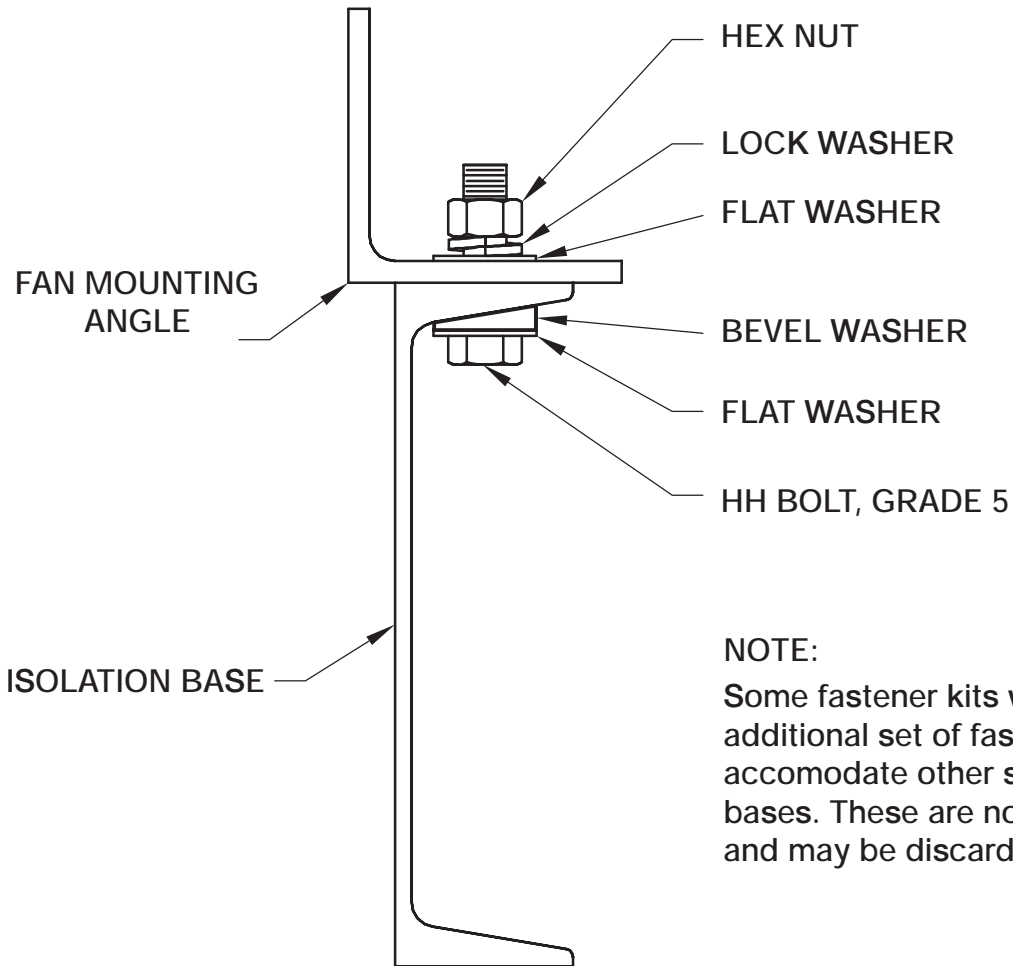

NOTE:

Some fastener kits will include an additional set of fasteners to accommodate other size fans and bases. These are not required and may be discarded.

Motor Slide Base

Motor slide bases are used for mounting a motor to the structural base. They are also used for making belt tension adjustments. Greenheck will ship the motor slide base pre-assembled to the structural base for arrangement 1 & 3 fan configurations.

NOTE: Design of base may vary by motor style.

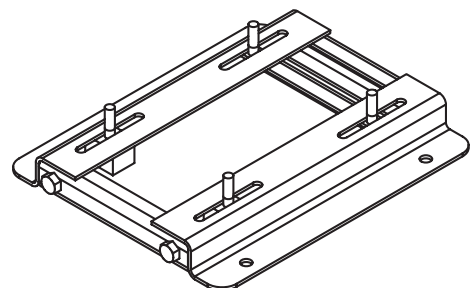

Motor Slide Base

Types of Isolation

There are several types of bases available for use with centrifugal/industrial process fans. Table 1 shows available uses for specific sizes and styles of fans.

Table 1

Arrangement	Fan Type	Direct Mount	Structural Base	Inertia Base
1	AF/BISW	No	Yes	Yes
	IPA*			
3	AF/BISW	No	Yes	Yes
	AF/BIDW			
4, 8	IPA*	Consult Factory	Yes	Yes
9	AF/BISW 7-36	Consult Factory	Yes	Yes
	IPA 5-19*			
	AF/BISW 40-73	Consult Factory	Yes	Yes
	IPA 21-41*			
10	AF/BISW 7-36	Yes	Yes	Yes
	AF/BISW 40-73	Consult Factory		
	IPA 5-19*	Yes		

Structural Base — Consult Factory on DB, BAD or TAD discharges.

Inertia Base — Not available on DB, BAD or TAD discharges.

*Consult Factory for isolation options for material handling fans (IPW/IPO)

Below are photos of the isolation types offered: Direct Mount [no structural base], Structural Base, and Inertia Base. Bases can be supplied with or without isolators. Contact a Greenheck representative for additional information on each type of base and their advantages.

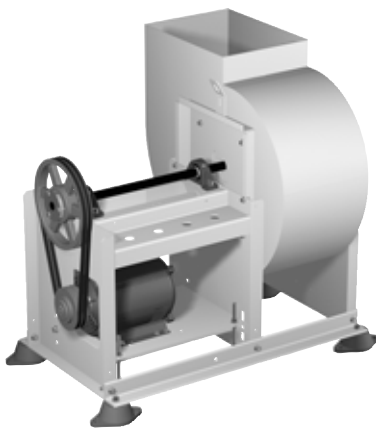

Direct Mount
with Neoprene Isolators



Structural Base or
Concrete Filled Inertia Base
with Free Standing Spring Isolators

Isolator Options

Greenheck offers several types of isolators for centrifugal products, including free-standing, restrained spring, housed spring, and neoprene mounts. Refer to pages 6 through 8 for installation instructions for the type of isolator shipped with the unit.

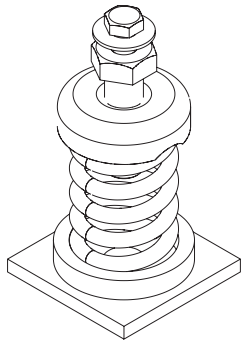

Free-Standing spring isolators are unboxed, laterally stable steel springs. They provide a minimum horizontal stiffness of 0.8 times the rated vertical stiffness and provide an additional 50% overload capacity. These isolators are equipped with a top mounted adjusting bolt and a non-skid, ribbed elastomeric pad to increase stability. Springs are color coded to indicate load capacity.

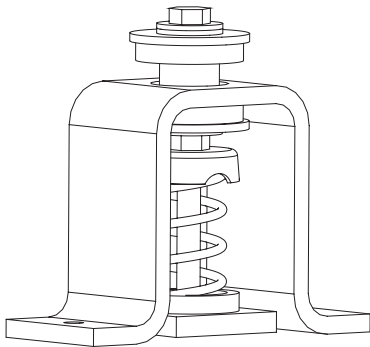

Restrained spring isolators consist of laterally stable, free-standing springs assembled in a steel housing. These assemblies are designed for vertical and horizontal motion restraint. Restrained spring isolators are provided with leveling bolts that can be used for blocking during equipment installation. Springs provide 50% overload capacity and are color coded to indicate load capacity. Restrained spring mounts are recommended for equipment subject to wind loading or large torquing forces. They are also used for equipment subject to large weight changes such as swingout fans.

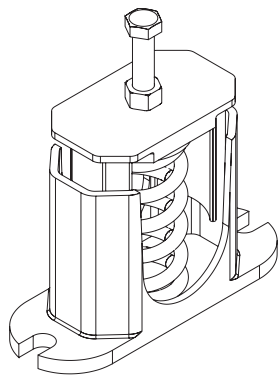

Housed spring isolators consist of steel springs assembled into a cast iron housing with a top mounted adjusting bolt and an acoustical non-skid base. Housed spring isolators include resilient inserts to prevent metal-to-metal contact and provide snubbing for side loads. Springs provide an additional 50% overload capacity and are color coded or identified to indicate load capacity.

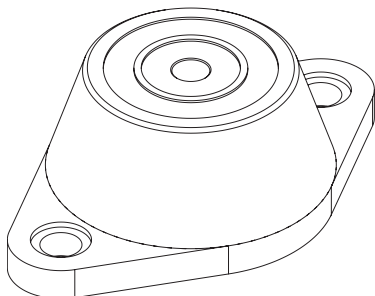

Neoprene Mountings consist of a steel top plate and base plate completely embedded in colored (oil-resistant) neoprene for easy capacity identification. Neoprene mountings are furnished with a tapped hole in the center. This enables the equipment to be bolted securely to the rubber mount.

*As a result of our commitment to continuous improvement,
Greenheck reserves the right to change isolator styles or vendors without notice.*

Installation Instructions for Free Standing Isolators

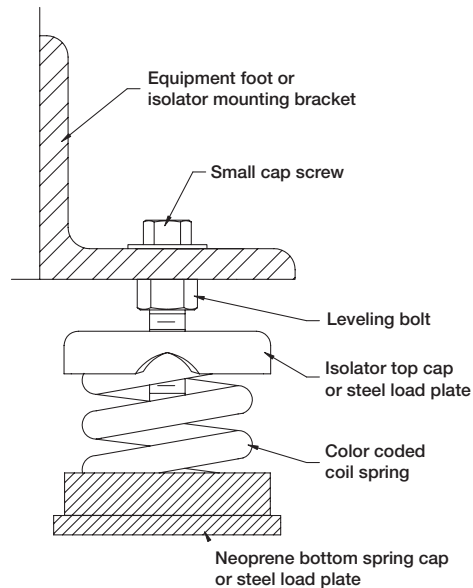

1. Thread the leveling bolt into the top load plate of the spring until the head of the bolt is within 1/8 inch of the top load plate of the spring.
2. Coordinate the location of each isolator with the appropriate submittal drawing and with the color code chart provided for each spring.
3. Remove the small cap screw and washer. Raise the equipment base with jacks or similar tools (do not attempt to raise the equipment via one (1) lifting point, but lift evenly around the perimeter of the equipment). Slide the spring isolator under the equipment or mounting bracket with the bolt head on the underside of the bracket.
4. Insert the small cap screw through the bracket and thread into the top of the leveling bolt and tighten finger tight.
5. If the equipment weighs 1000 lbs. or more, the placement of blocks beneath the equipment near each isolator point will assist installation. The height of each block should be such that the equipment will be at its required operating height when sitting on the blocks.
6. Lower the equipment (evenly) onto the spring isolators or blocks, taking care not to overload any one isolator and taking care not to push the equipment sideways.
7. For small equipment where blocks are not used, turn the leveling bolt counter clockwise on the lowest equipment corner until the equipment is level. Do not attempt to place all the weight on one spring, but distribute the load proportionately by adjusting each isolator in sequence.
8. For larger equipment where blocks are used, turn the leveling bolt counter clockwise until the equipment just comes free from the blocks. The blocks may then be removed. It may be desired to leave the equipment on the blocks until it is operating, thus eliminating future releveling should there be a major weight shift during equipment start up.
9. Continue to adjust each leveling bolt (in sequence) until the equipment is at its operating height, shown in the appropriate submittal drawing.
10. Tighten the small cap screw, thus securing the spring isolator to the supported equipment and locking the leveling bolt against turning.
11. Do not attempt to move the equipment laterally while it is supported on the isolators. If it is necessary to move the equipment, remove the weight from the isolators by raising the equipment. Failure to follow this procedure could result in bent or broken leveling bolts or springs, or damage to the neoprene bottom spring cap.

Installation Instructions for Restrained Spring Isolators

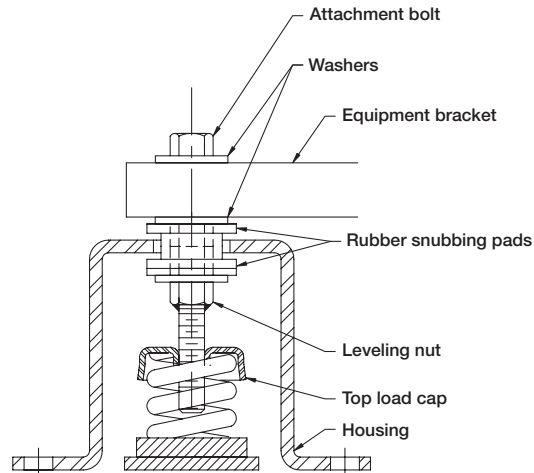

1. Coordinate the location of each isolator with the appropriate submittal drawing.
2. Remove the attachment bolt and one washer from the top of the leveling nut. Insert leveling nut assembly into the equipment bracket as shown in diagram. Be sure the top load cap is screwed all the way up to the leveling nut.
3. Align the fan base isolator holes and center the isolator housings on the leveling bolts. Lower the fan base onto the housing and mark the isolator housing anchor bolt locations.
4. Raise the fan base off the housings and install the isolator anchors in the floor.
5. Center the spring under the top load cap and lower the equipment. The isolator housing should support the equipment with approximately the desired floor clearance.
6. Loosely bolt equipment to the isolator using the attachment bolt.
7. Adjust the isolator by turning the leveling nut counterclockwise one turn. Repeat this step to each isolator leveling nut, one turn at a time, until the housing top plate is centered between the rubber snubbing pads on the leveling screw on all isolators.

NOTE: If one isolator reaches the desired position before the others, stop turning that leveling nut. It may be necessary to turn that leveling nut clockwise at some point to return it to the desired position once the other isolators reach their centered positions.

8. When all isolators have the housing top plate centered between the rubber snubbing pads on the leveling screw, install the anchor nuts to firmly attach the housing to the floor.
9. Tighten the attachment bolt, thus bolting the isolator to the supported equipment and locks the leveling bolt against turning.

Installation Instruction for Housed Spring Mounts

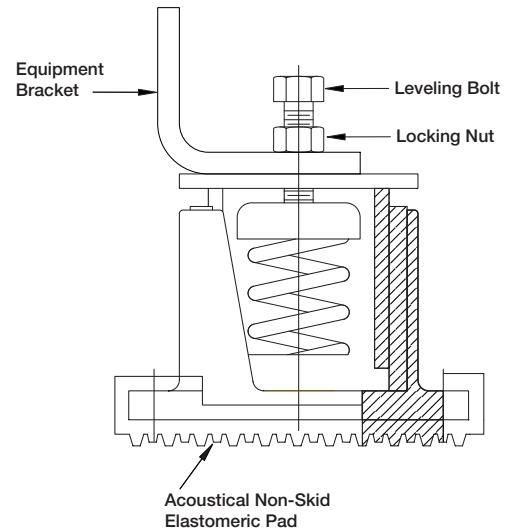
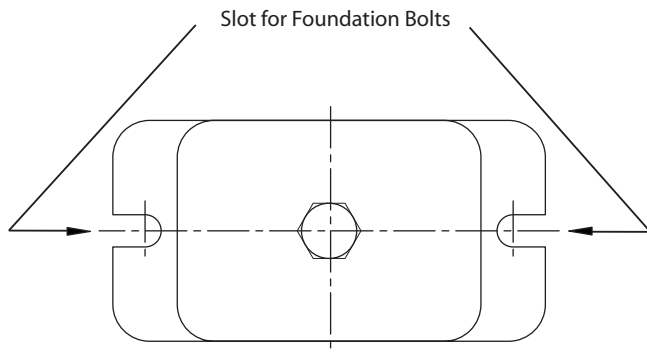

1. Set mountings on sub-base, shimming or grouting where required to provide a flat and level surface at the same elevation for base mountings (1/4 inch maximum difference in elevation can be tolerated). Support the full underside of the base plate; do not straddle gaps or small shims.
2. Bolt mountings to floor through slots.
3. Set the unit or base on the mountings. The weight of the unit will cause the upper housing of the mount to go down, possibly resting on the lower housing.
4. Turn nuts up on leveling bolts so that they will not interfere with the leveling procedure. Insert bolts through the holes in the fan or isolation base and turn them into the tapped hole in the upper housing of the mounting by hand as far as they will go.
5. With wrench, screw down one complete clockwise turn on the leveling bolt of each mounting. Repeat this procedure until 1/4 inch clearance between upper and lower housing is obtained on one or more mountings.
6. Take additional turns on all mountings having less than 1/4 inch clearance, until all mountings have at least this clearance.
7. Level the fan by taking additional turns on all mounts at the low side. Clearance should not exceed 1/2 inch. Greater clearance indicates that mountings were not all installed at the same elevation and shims are required.
8. Turn locking nut on leveling bolt down against fan or isolation base and lock in place with wrench to complete adjustments.