

Installation, Operation and Maintenance Manual

Please read and save these instructions for future reference. Read carefully before attempting to assemble, install, operate or maintain the product described. Protect yourself and others by observing all safety information. Failure to comply with instructions could result in personal injury and/or property damage!

General Safety Information

When Installing or Servicing the Fan

Do not depend on any switch as the sole means of disconnecting power when installing or servicing the fan. Always disconnect, lock and tag power source before installing or servicing. Failure to disconnect power source can result in fire, shock, or serious injury. Motor will restart without warning after thermal protector trips. Do not touch operating motor, it may be hot enough to cause injury.

Do not place any body parts or objects in fan, motor openings, or drives while motor is connected to power source.

Do not use this equipment in explosive atmospheres!

1. Read and follow all instructions and cautionary markings. Make sure electrical power source conforms to requirements of equipment and local codes.
2. Ventilators should be assembled, installed and serviced by a qualified technician. Have all electrical work performed by a qualified electrician.
3. Follow all local electrical and safety codes in the United States and Canada, as well as the National Electrical Code (NEC), the Occupational Safety and Health Act (OSHA), and the National Fire Protection Association (NFPA) Bulletin 96 in the United States. Ground motor in accordance with NEC Article 250 (grounding). Follow the Canadian Electric Code (CEC) in Canada.
4. Motor and fan must be securely grounded (bare metal) to a suitable electric ground, such as a grounded water pipe or ground wire system.

In United States, to reduce the risk of injury to persons, OSHA complying guards are required when fan is installed within 7 feet of floor or working level.

In Canada, to reduce the risk of injury to persons, CSA complying guards are required when fan is installed below 2.5 meters (8.2 feet) above floor or grade level.

1. Do not kink power cable or allow it to come in contact with sharp objects, oil, grease, hot surfaces or chemicals. Replace damaged cords immediately.
2. Make certain that the power source conforms to the requirements for the equipment.
3. Never open access door to a duct with the ventilator running.
4. Motor must be securely and adequately grounded. This can be accomplished by wiring with a grounded, metal-clad race way system by using a separate ground wire connected to the bare metal of the motor frame, or other suitable means.

Pre Starting Checks

1. Inspect for any damage that may have occurred during transit.
2. Shipping damage claim must be filed with carrier.
3. Check all bolts, screws, set-screws, etc. for looseness that may have occurred during transit. Retighten as required. Rotate propeller by hand to be sure it turns freely.

Installation

Installation, troubleshooting and parts replacement is to be performed only by a qualified personnel. Consult and follow applicable building codes which will supercede this document.

NOTE: Refer to motor nameplate for wiring procedures. Refer to switch manufacturer for installation and wiring procedures.

1. Cut an appropriate sized hole in the roof surface. Follow curb manufacturer's installation instructions. Caulk and flash curb to ensure a water tight seal.
2. Install optional backdraft damper. Secure damper flange to curb damper tray, with fasteners provided.
3. Remove motor cover.
4. Place ventilator on curb.
5. Secure ventilator to roof curb using a minimum of eight fasteners.
6. Check ventilator propeller for free rotation.
7. Check all fasteners for tightness.
8. Mount and wire safety disconnect switch under ventilator cover and wire motor per wiring diagram on motor.
9. Replace motor cover.
10. Wire control switches at ground level.

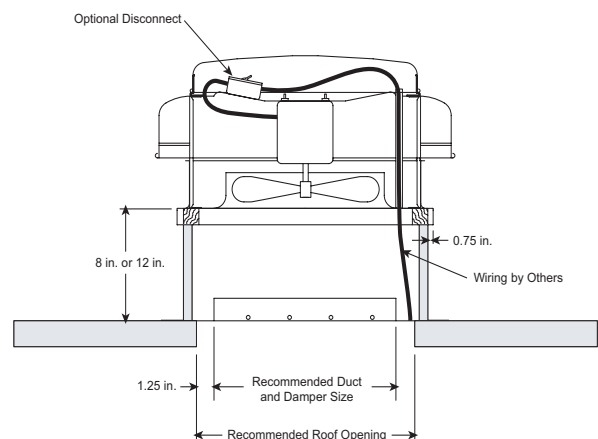

Operation

1. Before starting up or operating, check all fasteners for tightness. In particular, check set screws in propeller hub. While in the OFF position, or before connecting the ventilator to power, turn the fan propeller by hand to be sure it is not striking the venturi or any obstacle.
2. Start the ventilator up and shut it off immediately to check rotation of the propeller with directional arrow in the motor compartment. Ventilator propeller should rotate counter-clockwise on all models when viewed from the top and *clockwise for size 10 only*.
3. When the ventilator is started, observe the operation and check for any unusual noises.
4. With the system in full operation and all duct work attached, measure current input to the motor and compare with the nameplate rating to determine if the motor is operating under safe load conditions.
5. Keep inlets and approaches to ventilator clean and free from obstruction.

Maintenance

Disconnect and lockout power source before servicing.

Uneven cleaning of the propeller will produce an out of balance condition that will cause vibration in the ventilator.

1. Keep inlets and approaches to ventilator clean and free from obstruction. Depending on the usage and severity of the contaminated air, a regularly scheduled inspection for cleaning the fan propeller, ventilator, and surrounding areas should be established.
2. Check for unusual noises when fan is running.
3. Periodically inspect and tighten set-screws.
4. Follow motor manufacturer's instructions for motor lubrication.

Parts List

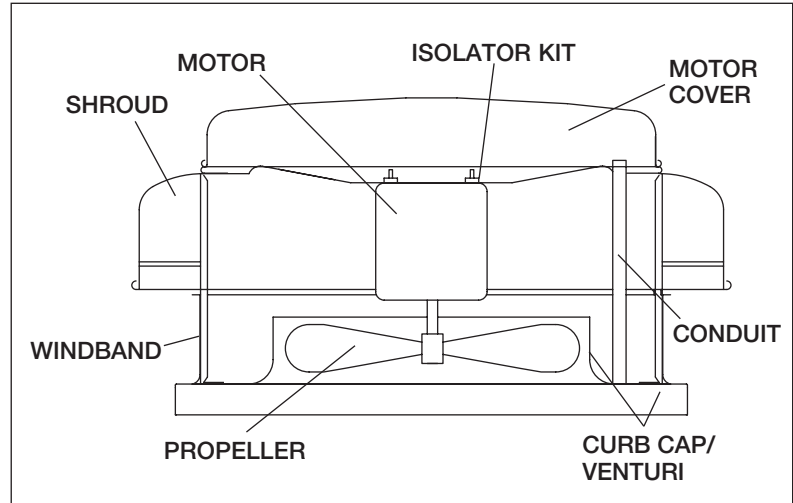

Troubleshooting

Problem	Cause	Corrective Action
Ventilator Inoperative	Blown fuse or breaker	Replace or repair motor
	Defective motor	Replace or repair
	Incorrectly wired	Shut power OFF and check wiring for proper connections
Insufficient Airflow	Blocked duct or clogged filters	Clean or replace
	Speed too slow	Check for correct drives
	Damper closed	Inspect/repair damper
	Incorrect propeller rotation	Check motor wiring
	Loose fitting duct sections	Check for secure connection where duct permitting air loss sections are joined (suggest duct tape at seams for sealed closure)
Excessive Noise or Vibration	Loose propeller	Tighten set screws
	Accumulation of material on propeller	Clean
	Ventilator base not securely anchored	Secure properly
	Motor hood loose and rattling	Tighten acorn nuts securing motor hood
	Fan propeller out of balance	Replace propeller
Motor Overloads or Overheats	Propeller RPM too high	Check drives
	Shorted motor winding	Replace motor
	Incorrect propeller rotation	Check motor wiring
	Over/Under line voltage	Contact Power Company

Warranty

Greenheck warrants this equipment to be free from defects in material and workmanship for a period of one year from the shipment date. Any units or parts which prove to be defective during the warranty period will be replaced at our option when returned to our factory, transportation prepaid. Motors are warranted by the motor manufacturer for a period of one year. Should motors furnished by Greenheck prove defective during this period, they should be returned to the nearest authorized motor service station. Greenheck will not be responsible for any removal or installation costs.

As a result of our commitment to continuous improvement, Greenheck reserves the right to change specifications without notice.

Greenheck Centrifugal Utility Fan catalog provides additional information describing the equipment, fan performance, available accessories, and specification data.

AMCA Publication 410-96, Safety Practices for Users and Installers of Industrial and Commercial Fans, provides additional safety information. This publication can be obtained from AMCA International, Inc. at www.amca.org.

