

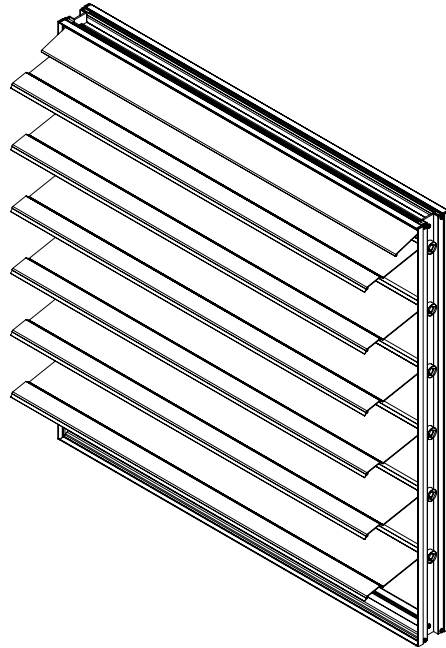

**Part number 468391
ES, EM & GM series**

Installation, Operation, and Maintenance Instructions

This manual is the property of the owner, and is required for future maintenance. Please leave it with the owner when the job is complete.



RECEIVING AND HANDLING

Upon receiving dampers, check for both obvious and hidden damage. If damage is found, record all necessary information on the bill of lading and file a claim with the final carrier. Check to be sure that all parts of the shipment, including accessories, are accounted for.

Dampers must be kept dry and clean. Indoor storage and protection from dirt, dust and the weather is highly recommended. Do not store at temperatures in excess of 100°F(37°C).

SAFETY WARNING:

Improper installation, adjustment, alteration, service or maintenance can cause property damage, injury or death. Read the installation, operating, and maintenance instructions thoroughly before installing or servicing this equipment.

Due to continuing research, Greenheck reserves the right to change specifications without notice.

Pre-Installation Guidelines

The basic intent of a proper installation is to secure the damper into the opening in such a manner as to prevent distortion and disruption of damper operation. The following items will aid in completing the damper installation in a timely and effective manner.

- 1) Check the schedules for proper damper locations within the building. Visually inspect the damper for damage.
- 2) Lift or handle damper using sleeve or frame. Do not lift damper using blades or linkage. When handling multiple sections assemblies, use sufficient support to evenly lift at each section mullion (see drawing). Do not drag, step on, apply excessive bending, twisting, or racking. (See Figure 1)
- 3) Do not install screws in damper frame that will interfere with damper blades and prevent them from opening and/or closing.

Pre-Installation Guidelines continued...

- 4) Damper must be installed into duct or opening square and free of twist or other misalignment. Damper must not be squeezed or stretched into duct or opening. Out of square, racked, twisted or misaligned installations can cause excessive leakage and/or torque requirements to exceed damper/actuator design.
- 5) Damper must be kept clean, dry and protected from dirt, dust and other foreign materials prior to and after installation. Examples of such foreign materials include but are not limited to:
 - a) Drywall/mortar dust
 - b) Firesafing materials
 - c) Wall texture
 - d) Paint overspray
- 6) Damper should be sufficiently covered as to prevent overspray if wall texturing or spray painting will be performed within 5 feet (1.50m) of the damper. Excessive dirt or foreign material deposits on damper can cause excessive leakage and/or torque requirements to exceed damper/actuator design.
- 7) ACCESS: Suitable access (actuators maintenance, etc.) must be provided for damper inspection and servicing. Where it is not possible to achieve sufficient size access, it will be necessary to install a removable section of duct.

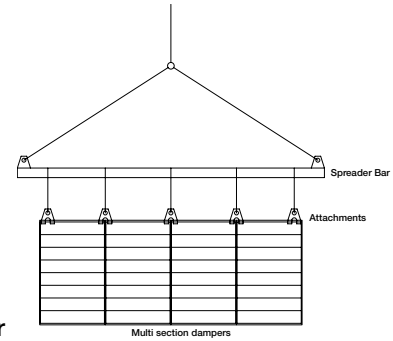

Figure 1

EM/ES/GM Damper Counterbalance Adjustment Procedure

The following instructions should be followed when attempting to maximize the counterbalance effect on the EM or GM model dampers. Be aware that when the balance setting is highly sensitive, friction wear and contamination will have an adverse effect to the operation of the damper. The sensitivity of the counterbalance should only be set to meet the application requirements. The damper must be mounted square and plumb and operate freely before any weight adjustments are performed.

Counterbalance adjustment for EM/ES/GM-30, 31 & 32 Models: Vertical Mount – Horizontal Airflow

Adjustment #1 will effect the balance of the blades in the open position. Adjustment #2 will effect the balance of the blades in the closed position along with a small change to the open position balance.

If the damper blades do not achieve full open position under airflow and you want them to open further or all the way, then adjustment #1 will need to be performed. If the damper blades do not open completely and adjustment #1 has been addressed, then more weight is required.

If the airflow through the damper is light and the blades only slightly move from the closed position, then adjustment #2 and #1 are required.

Adjustment #1:

Moving the weight stack along the length of the mounting bracket slot will effect the full open balance of the blade assembly. Moving the weights further away from the blade pivot point will cause the blades to become more balanced so that at some point, and with enough weight, the blades would remain open. Care must be taken to ensure that when the weights are moved outward from the blade pivot point they will not interfere with the adjacent blade when the blades close. Moving the weights back towards the blade pivot point will allow the blades to close.

Adjustment #2:

The damper is assembled with the counterbalance weights and bracket installed such that, when the blades are closed, the counterbalance weights and bracket are positioned directly inline with the blade pivot points. This position of the weights will provide a slight load that will hold the blades in the closed position. To reduce this load, the counterweight-mounting brackets can be bent away from the adjacent blade surface. Bending the counterweight mounting brackets will move the counterweight stack behind the blade pivot point and therefore allow the blades to start opening at lower airflow rates. This adjustment should be performed in small increments since the blades will not fully close if the brackets are bent to far. Performing adjustment #2 will have a small effect on adjustment #1 therefore, if adjustment #1 is critical, then adjustment #1 may need to be repeated.

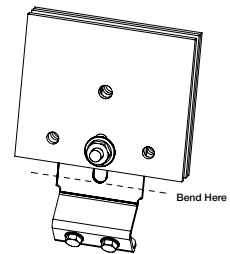
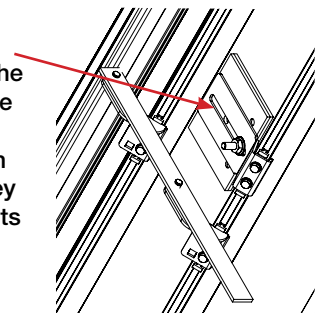

Counterbalance Adjustment for EM/ES-10, 11 & 12 Models: Horizontal Mount - Vertical Airflow Up

Adjustment #1 will effect the balance of the blades in the closed position. Adjustment #2 will effect the balance of the blades in the open position along with a small change to the balance in the closed position balance.

If the damper blades are partially opening under airflow and you want them to open further or all the way, then adjustment #1 will need to be performed. If the blades remain in the full open position then adjustment #2 is required.

If the airflow through the damper is light and the blades only slightly move from the closed position, then adjustment #1 is required. If the airflow through the damper is light and the blades do not reach full open position then adjustment #2 may be excessive or adjustment #1 may need to be increased or both adjustments may need to be addressed.

Adjustment #1:

Moving the weight stack along the length of the mounting bracket slot will effect the full closed balance of the blade assembly. Moving the weights further away from the blade pivot point will cause the blades to become more balanced so that at some point, and with enough weight, the blades would remain open without air pressure being applied. Care must be taken to ensure that when the weights are moved away from the blade pivot point the weights will not interfere with the adjacent blade when the blades close. Moving some of the weights back towards the blade pivot point will allow the blades to return to the closed position.

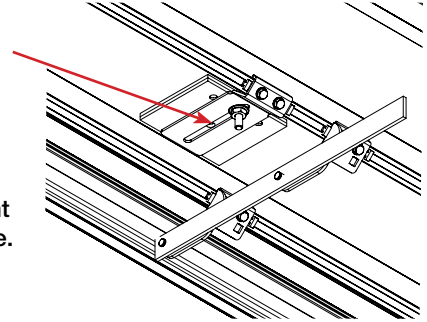

Adjustment #2:

The damper is factory assembled with the counterbalance assembly installed such that, the counterbalance weights and bracket are positioned at a slight angle to the surface of the blade. This angle will position the weights such that they will provide a slight load that will cause the blades to rotate from the full open position toward the closed position. If for some reason the blades remain in the open position then you will need to increase this load. To do this the counterweight-mounting brackets should be bent further away from the blade surface. Bending the counterweight mounting brackets will move the counterweight stack away from the blade surface and therefore the torsion effect will force the blades to start closing. This adjustment should be performed in small increments to each weight bracket. Performing adjustment #2 will have a small effect on adjustment #1 therefore, if adjustment #1 is critical, then adjustment #1 may need to be repeated.

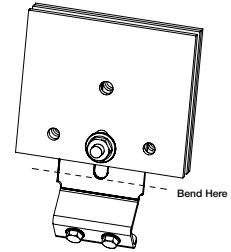

Counterbalance Adjustment for EM/ES-40, 41 & 42: Horizontal Mount - Vertical Airflow Down

Adjustment #1 will effect the balance of the blades in the closed position. Adjustment #2 will effect the balance of the blades in the open position along with a small change to the balance in the closed position.

If the damper blades are only opening partially under airflow and you want them to open further or all the way, then adjustment #1 will need to be performed. If the damper blades do not close completely and adjustment #1 has been addressed, then more weight is required. If the blades remain in the full open position then adjustment #2 is required.

If the airflow through the damper is light and the blades only slightly move from the closed position, then adjustment #1 is required.

Adjustment #1:

Moving the weight stack along the length of the mounting bracket slot will effect the full closed balance of the blade assembly. Moving the weights closer to the blade pivot point will cause the blades to become less balanced so that at some point, the blades would fall open. Care must be taken to ensure that when the weights are moved outward from the blade pivot point the weights will not interfere with the adjacent blade when the blades close. Moving the weights away from the blade pivot point will force the blades to close properly. Care must be taken to ensure that when the weights are moved outward from the blade pivot point the weights will not interfere with the adjacent blade when the blades close. Performing adjustment #1 will have a small effect on adjustment #2 therefore, if adjustment #2 is critical, then adjustment #2 may need to be repeated.

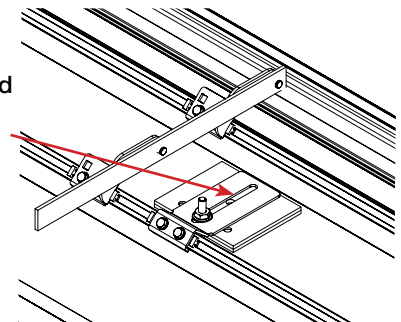

Adjustment #2:

The damper is factory assembled with the counterbalance weights and bracket installed such that, when the blades are closed, the counterbalance weights and bracket are positioned directly inline or slightly ahead of the blade pivot points. The position of the weights will provide a slight load that will cause the blades to rotate from the full open position toward the closed position. To increase this load, the counterweight-mounting brackets can be bent toward the adjacent blade surface. Bending the counterweight mounting brackets will move the counterweight stack which will force the blades to start closing. This adjustment should be performed in small increments to each weight bracket since bending the brackets too much will cause the weight stack to interfere with the adjacent blade surface. Performing adjustment #2 will have a small effect on adjustment #1 therefore, if adjustment #1 is critical, then adjustment #1 may need to be repeated.

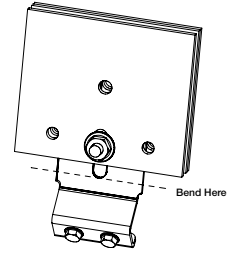

Multi-section Assembly

When the finished damper assembly is made up of multiple sections, the sections will require field assembly. Frame clips are provided for this purpose. The frame clips are a snap fit component that fit over the joint between adjoining sections. The clips will require the use of a rubber hammer or similar tool to install as shown below. Install frame clips on the front side and backside of the assembly. For added strength, screws may be used on the backside of the frames in lieu of or in addition to the frame clip. Do not install screws on the front side of the frame where they could interfere with the operation of the blades.

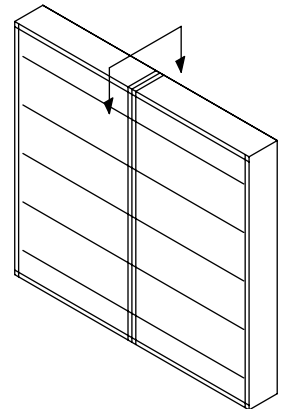
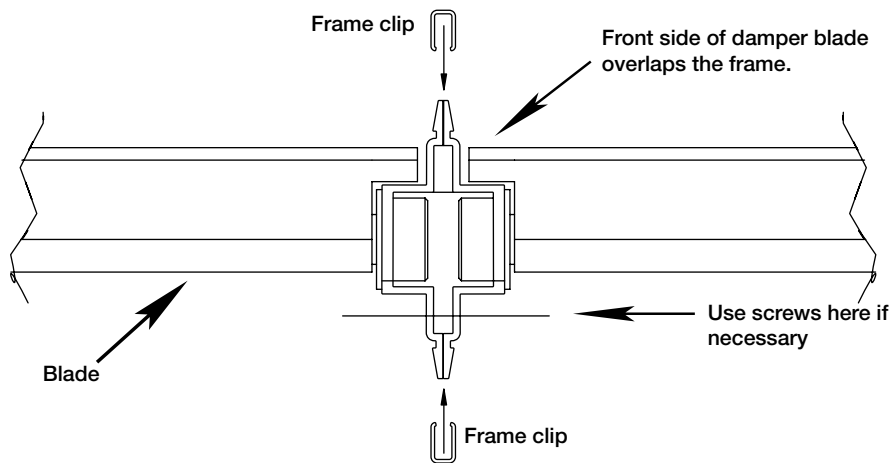

Vertical joint shown. Horizontal joint is similar.

