



GREENHECK

Fire and Combination Fire Smoke Dampers
Vertical or Horizontal Mount

Part number 464603
IMO-XXX & SSIMO-XXX series
Vertical or Horizontal Mount

Installation, Operation and Maintenance Instructions

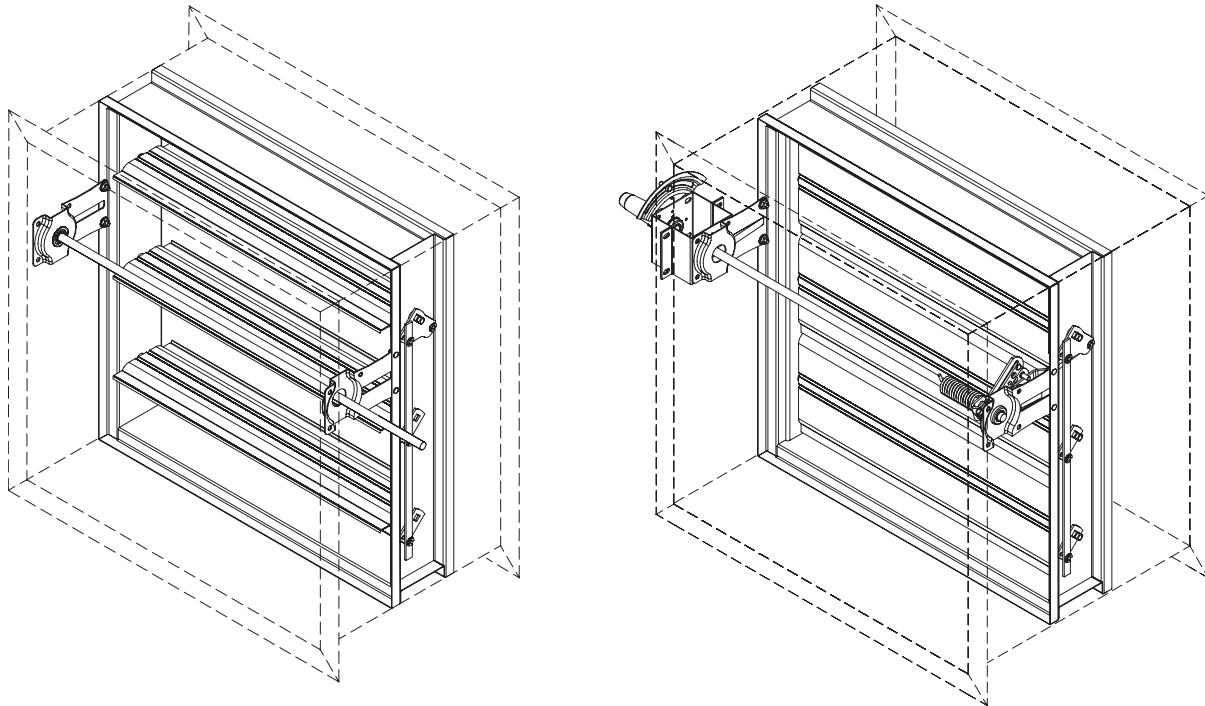

International Maritime Fire Test Procedure Code

USCG Type Approved
Approval Number 164.139/0007/0

RECEIVING AND HANDLING

Upon receiving dampers, check for both obvious and hidden damage. If damage is found, record all necessary information on the bill of lading and file a claim with the final carrier. Check to be sure that all parts of the shipment, including accessories, are accounted for.

Dampers must be kept dry and clean. Indoor storage and protection from dirt, dust and the weather is highly recommended. Do not store at temperatures in excess of 100°F (37°C).

WARRANTY

Greenheck warrants this equipment to be free from defects in material and workmanship for a period of one year from the shipment date. Any units or parts which prove to be defective during the warranty period will be repaired or replaced at our option. Greenheck shall not be liable for damages resulting from misapplication or misuse of its products. Greenheck will not be responsible for any installation or removal costs. Greenheck will not be responsible for any service work or backcharges without prior written authorization.

SAFETY WARNING:

Improper installation, adjustment, alteration, service or maintenance can cause property damage, injury or death. Read the installation, operating, and maintenance instructions thoroughly before installing or servicing this equipment.

This manual is the property of the owner, and is required for future maintenance. Please leave it with the owner when the job is complete.

Installation Instructions

Greenheck's IMO dampers were tested per the International Maritime Organization's Fire Test Procedure (FTP) code in a Class A bulkhead and in a Class A deck for 60 minutes. The FTP code requires that the ductwork (coaming) be insulated and that the damper be bolted or welded to the duct.

1. Insulating the Duct

The ductwork must be insulated a minimum of 6 in. (152mm) on the damper side and 18 in. (457mm) on the non-damper side (see figures 1-4). Any US Coast Guard type approved insulation with an A60 rating can be used. The insulation is to be installed on the duct with 0.106 in. (2.7mm) steel pins and 1.12 in. x 1.24 in. x 0.4 in. (28mm x 31mm x 10mm) steel clips.

2. Attaching Damper to Duct

The damper can be installed to the duct using either bolts or welding. If bolts are used, they are to be a minimum of 0.375 in. (9.5mm) diameter and 1 in. (25mm) long. The fasteners should be spaced 6 in. (152mm) OC and a maximum of 2 in. (51mm) from the corners.

Horizontal Airflow- Vertical Damper mount

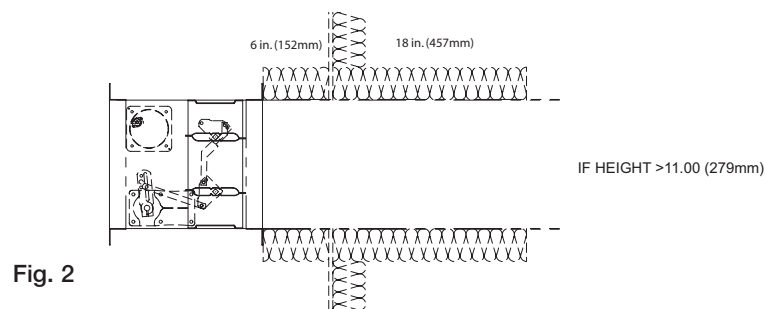
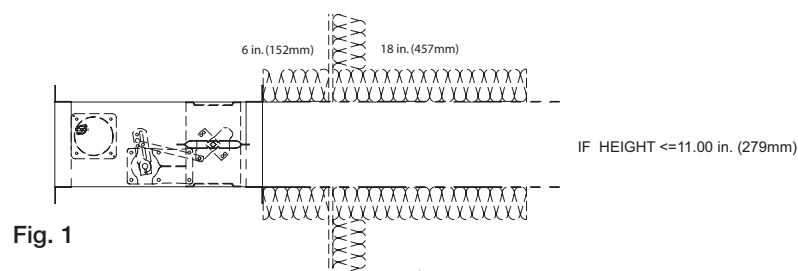

Vertical Airflow- Horizontal Damper mount

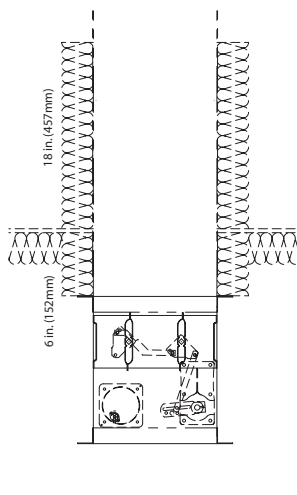
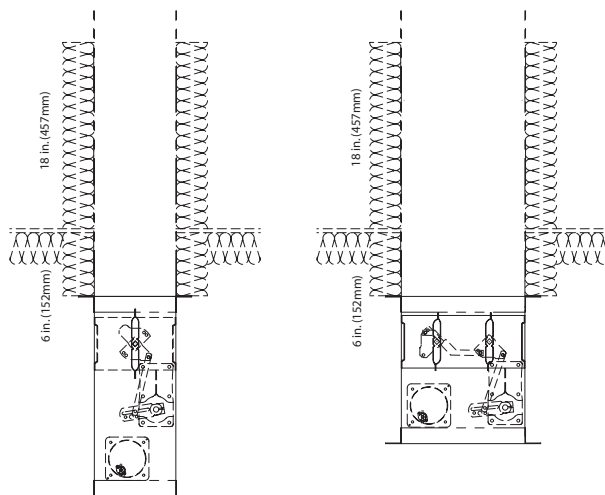

Size Limitations

Damper model	Maximum Single Section size	Maximum Overall size for Multi-section dampers
IMO-310	32 in. x 32 in. (813mm x 813mm)	64 in. x 32 in. (1626mm x 813mm)
SSIMO-310	32 in. x 32 in. (813mm x 813mm)	64 in. x 32 in. (1626mm x 813mm)
IMO-311	32 in. x 32 in. (813mm x 813mm)	64 in. x 32 in. (1626mm x 813mm)
SSIMO-311	32 in. x 32 in. (813mm x 813mm)	64 in. x 32 in. (1626mm x 813mm)

Manually operated dampers (IMO-310 & SSIMO-310)

Manually operated dampers utilize a spring and fusible link assembly to close the damper during elevated temperature conditions. No electrical power is required for these models.

Motor operated dampers (IMO-311 & SSIMO-311)

Motor operated dampers are supplied with an electric thermal response device which cuts power to the spring return actuator upon sensing an elevated temperatures. See below for electrical connections.

Connection and Operation of Temperature Response Devices (RRL standard, OCI option, and PRV option)

RRL - Dampers will be supplied with a thermostat-type temperature response device, as a standard. The device is a RRL (resettable link device), which only incorporates one thermostat and therefore the damper remains closed as soon as its sensor temperature is reached. The RRL does not contain blade indication switches. Refer to **Figure 5** for wiring of the RRL thermostat.

If RRL is ordered with a pneumatic actuator, an EP switch is required with an appropriate electric power circuit to allow the electric thermostat to control the pneumatic actuator.

OCI - The OCI (open or closed indicator) option contains a single pole, double throw switch used to indicate the damper blade

position. The switch provides a positive open or closed signal when used in conjunction with remote indicator lights. Refer to **Fig. 6** for wiring of the OCI option.

PRV - The PRV (pneumatic relief valve) option is heat responsive device used with pneumatic actuators. This can be used in place of EP switch where a RRL is used. The PRV activates when temperature in excess of the temperature of the fusible link are detected. When the fusible link melts, air from the actuator is exhausted to close the dampers. Pneumatic actuators are to be piped per local code.

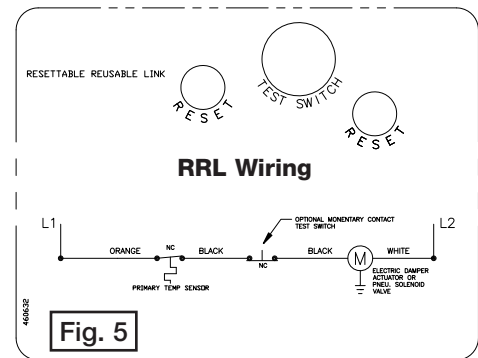

Fig. 5

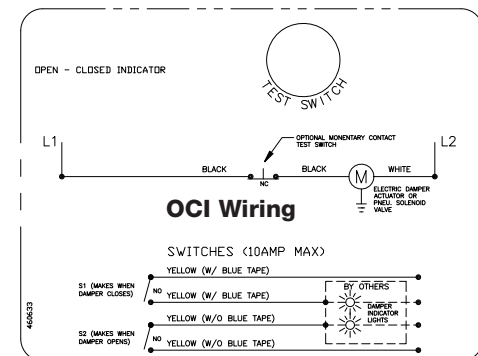

Fig. 6

RATINGS

Integral Switch Type: Single Pole, double throw

Electrical Capacity: 10 Amps, 1/3 hp, 120 or 240 Vac
 1/2 Amp, 125 Vdc; 1/4 Amp 250 Vdc
 5 Amps, 120 Vac "L" (lamp load)
 1.0 Amps, 24 Vac
 1.5 Amps, 24 Vdc

Temperature Limit: 165° F (standard primary sensor)
 212° F (optional primary sensor)

Damper Maintenance

Dampers do not typically require maintenance as long as they are kept dry and clean. If cleaning is necessary, use mild detergents or solvents. If lubrication is desired for components such as axle bearings, jackshaft bearings and jamb seals, do not use oil-based lubricants or any other lubricants that attract contaminants such as dust.

Dampers and their actuator(s) must be maintained, cycled, and tested in accordance with:

- The latest editions of NFPA 80, 90A, 92A, UL864, and local codes.
- Actuator manufacturer recommendations.

Damper Trouble Shooting

The following is a possible cause and correction list for common concerns with the dampers.

Symptom	Possible Cause	Corrective Action
Damper does not fully open and/or fully close	Frame is 'racked' causing blades to bind on jamb seals	Adjust frame such that it is square and plumb
	Actuator linkage loose	Close damper, disconnect power, adjust and tighten linkage
	Defective motor	Replace
	Screws in damper linkage	Locate screws and remove
	Actuator linkage hitting wall or floor	Damper installed too far into wall. Move out to line designated on damper label.
	Contaminants on damper	Clean with a non-oil-based solvent (see Damper Maintenance)
RRL or TOR sensor tripped	Heat	Push reset button located on backside of RRL or TOR.
Damper does not operate	No power supplied to the actuator	

