

# MODEL TSU Make-Up Air Unit

Part # 464441



Installation

Start-Up

Operation

Troubleshooting

Maintenance

Reference

## FOR YOUR SAFETY

If you smell gas

1. Open windows
2. Don't touch electrical switches
3. Extinguish any open flames
4. Immediately call your gas supplier

## FOR YOUR SAFETY

The use and storage of gasoline or other flammable vapors and liquids in open containers in the vicinity of this appliance is hazardous.

## \*\*WARNING\*\*

Disconnect and secure all electrical power to the "OFF" position prior to inspection or servicing. Failure to comply with this safety precaution could result in serious injury or death.

## \*\*WARNING\*\*

Improper installation, adjustment, alteration, service or maintenance can cause property damage, injury or death. Read the installation, operating, and maintenance instructions thoroughly before installing or servicing this equipment.

## \*\*IMPORTANT\*\*

All factory provided lifting lugs must be used when lifting any unit. Failure to comply with this safety precaution could result in property damage, serious injury or death.

## Report any damaged equipment to the shipper immediately!

All units are shipped on a skid or packaged to minimize damage during shipment. The transporting carrier has the responsibility of delivering all items in their original condition as received from Greenheck. The individual receiving the equipment is responsible for inspecting the unit for obvious or hidden damage, recording any damage on the bill of lading before acceptance and filing a claim (if required) with the final carrier. Some accessory items are stored inside the unit during shipping. Care must be taken during installation to prevent damage to units.



# TABLE OF CONTENTS

<b>I</b>	<b>Installation</b>	
	Unit - Slab Mounted	.I-1
	Unit - Rail Mounted	.I-2
	Unit - Curb Mounted	.I-3
	Filter Section / Weatherhood	.I-5
	Evaporative Cooler	.I-6
	Evaporative Cooling Piping	.I-7
	Water Wizard™ Evaporative Control	.I-9
	Electrical Wiring	.I-10
	Direct Gas Piping	.I-13
	Building Pressure Control	.I-15

<b>S</b>	<b>Start-Up</b>	
	Blower	.S-1
	Direct Gas	.S-3
	Evaporative Cooling	.S-9
	Water Wizard™ Evaporative Controls	.S-11

<b>O</b>	<b>Operation</b>	
	Recirculating/VAV Units	.O-1
	Electrical	.O-2
	Water Wizard™ Evaporative Control	.O-3

<b>T</b>	<b>Troubleshooting</b>	
	Blower	.T-1
	Heater	.T-2
	Vibration	.T-5
	Evaporative Cooler	.T-6
	Water Wizard™ Evaporative Control	.T-7

<b>M</b>	<b>Maintenance</b>	
	Routine	.M-1
	Fall	.M-4
	Log	.M-5

<b>R</b>	<b>Reference</b>	
	Gas Train Layout	.R-1
	Control Center Layout	.R-2
	Warranty	.R-2

## STORAGE

When a unit is not going to be in service for an extended period of time, certain procedures should be followed to keep the unit in proper operating condition:

- Plug all piping
- Rotate fan wheel monthly and purge bearings once every one to three months (depending on environment).
- Energize fan motor once every three months
- Store belts flat to keep them from warping and stretching
- Store unit in location without vibration
- Cover unit with tarp to protect from dirt and moisture
- After storage period, purge grease before putting fan into service

### NOTE!

Do not cover unit with a black tarp, this would promote condensation.

### NOTE!

Improper storage which results in damage to the unit will void the warranty.

# Installation - Slab Mounted Unit

## Step 1 Pour Concrete Slab

Pour the concrete slab. The slab should be one foot larger than the unit on all sides. The slab should be at least four inches thick and poured on a bed of gravel to ensure proper drainage. Allow the concrete slab to properly cure before installing the unit.

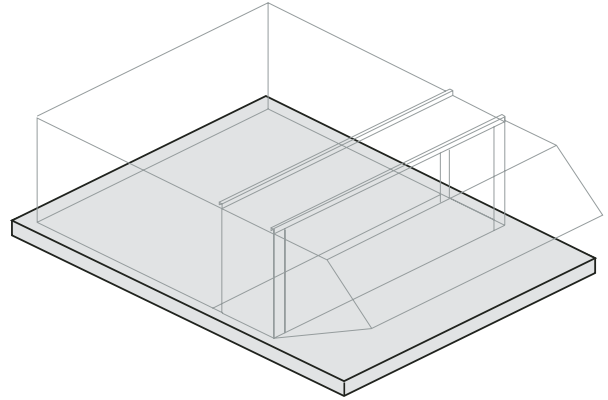

## Step 2 Install Unit

Use a crane and a set of spreader bars hooked to the factory lifting lugs to lift and center the unit on the concrete slab. Fasten the unit to the slab through the factory provided lifting lugs.

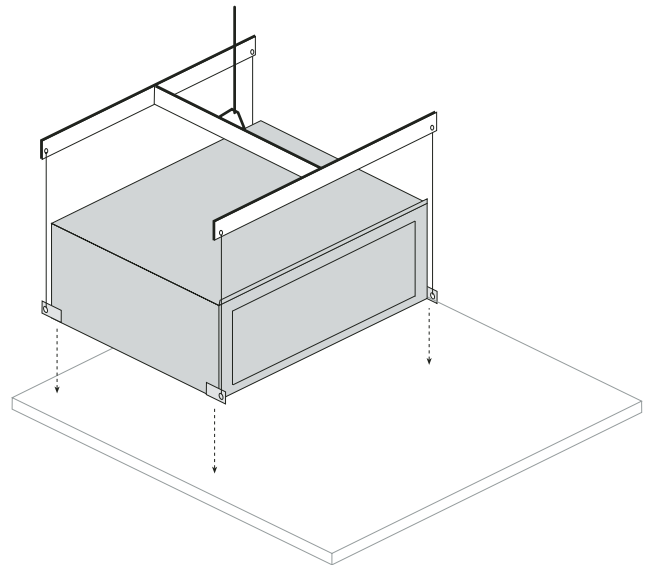

### NOTE!

The use of all lifting lugs and a set of spreader bars is mandatory when lifting the unit.

### NOTE!

For easy installation, it is recommended that the weatherhood, filter section or evaporative cooler be installed after the base unit.

## Step 3 Attach Ductwork

Refer to the CAPS submittal for the duct size and location. Greenheck recommends attaching ductwork using a rubber duct section at the unit to reduce vibration. An appropriate sealant should be used around the discharge opening of the unit to create a weather tight seal.

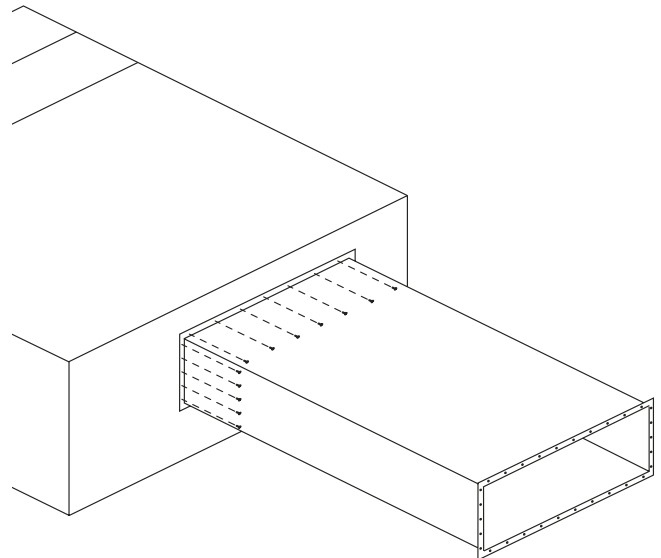

### NOTE!

Good duct practices should be followed for all ductwork. Ductwork should be installed in accordance with SMACNA and AMCA guidelines, NFPA 96 and any local codes.

# Installation - Rail Mounted Unit

## Step 1 Install Rails

Install the rails. The rails should be located 6 - 12 inches in from the sides of the unit. The rails should extend at least six inches past the intake and discharge ends of the unit. Rails are field supplied by other and are not supplied by Greenheck.

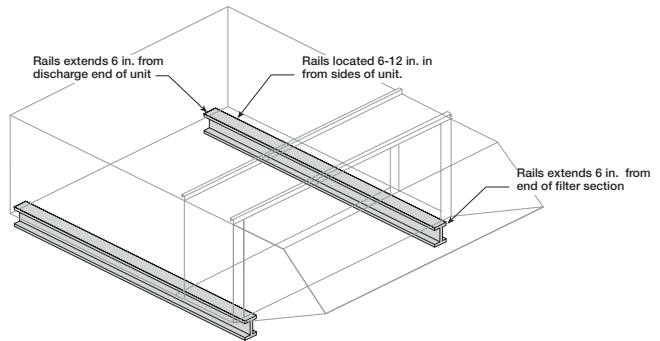

1-2

## Step 2 Install Unit

Use a crane and a set of spreader bars hooked to the factory lifting lugs to lift and center the unit on the rails.

### NOTE!

The use of all lifting lugs and a set of spreader bars is mandatory when lifting the unit.

### NOTE!

For easy installation, it is recommended that the weatherhood, filter section or evaporative cooler be installed after the base unit.

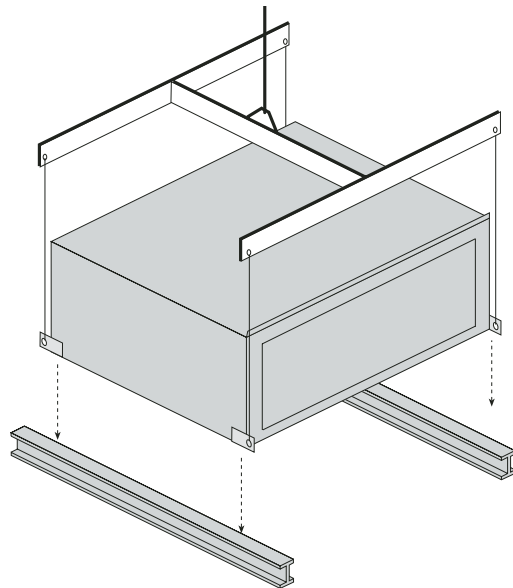

## Step 3 Attach Ductwork

Refer to the CAPS submittal for the duct size and location. Greenheck recommends attaching ductwork using a rubber duct section at the unit to reduce vibration. An appropriate sealant should be used around the discharge opening of the unit to create a weather tight seal.

### NOTE!

Good duct practices should be followed for all ductwork. Ductwork should be installed in accordance with SMACNA and AMCA guidelines, NFPA 96 and any local codes.

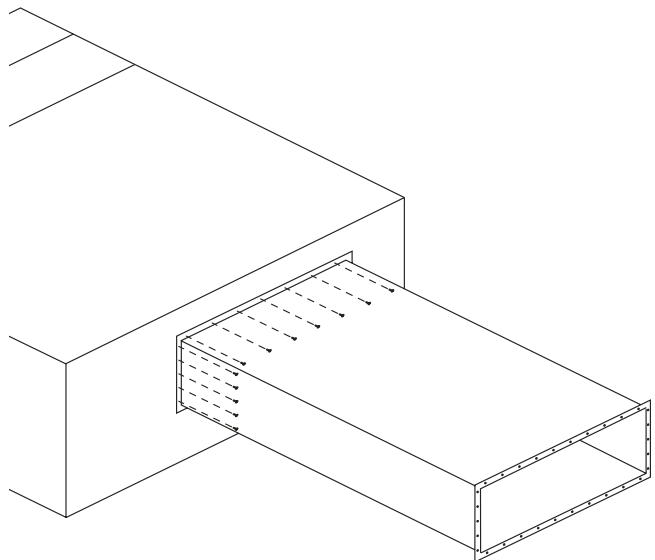

# Installation - Curb Mounted Unit

## Step 1 Install Curb

Position curb on the roof (refer to the CAPS submittal section for placement of curb in relation to the unit). Verify that the curb is level, shim if necessary. Attach curb to roof and flash into place.

## Step 2 Install Ductwork

If the unit has a downblast (DB) discharge, install the supply air duct now.

If the unit requires a return air duct, install it now.

If the unit has a horizontal (HZ) discharge, wait until the base unit is installed before installing the supply duct.

Good duct practices should be followed for all ductwork. All ductwork should be installed in accordance with SMACNA and AMCA guidelines, NFPA 96 and all local codes. Refer to the CAPS submittal for the ductwork sizes.

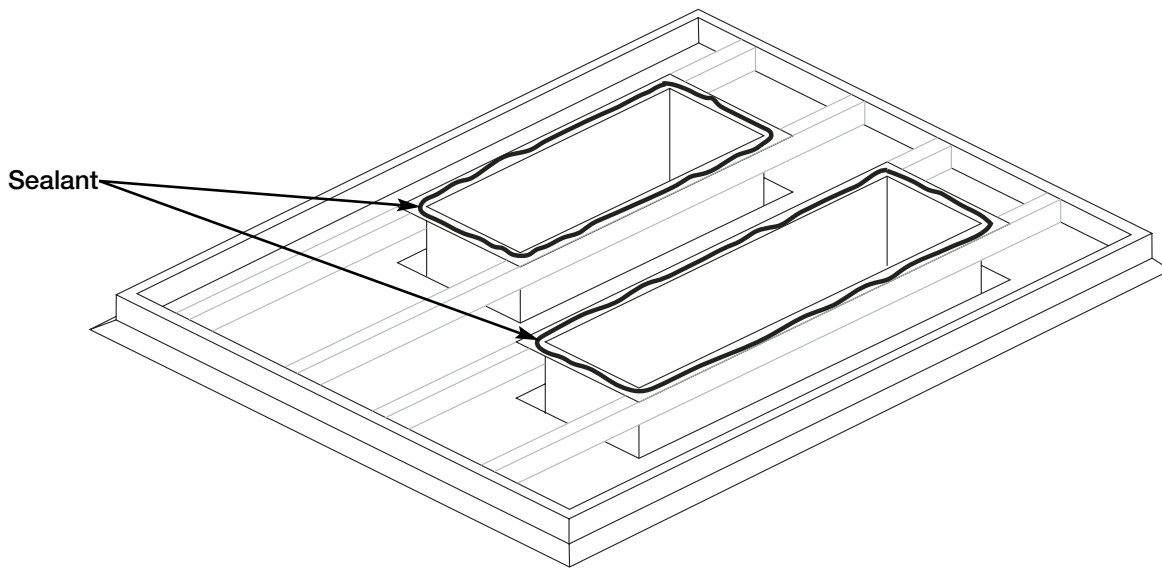

### NOTE!

The use of a duct adapter is recommended on a downblast (DB) arrangement to align the ductwork with the supply unit and is only a guide and is not to be used as ductwork support.

## Step 3 Apply Sealant

Apply an appropriate sealant around the perimeter of the curb and duct adapter(s) to isolate fan vibration and prevent water penetration.

# Installation - Curb Mounted Unit

## Step 4 Install Unit

Use a crane and a set of spreader bars hooked to the factory lifting lugs to lift and center the unit on the curb.

Use self-tapping sheet metal screws to fasten the unit to the curb.

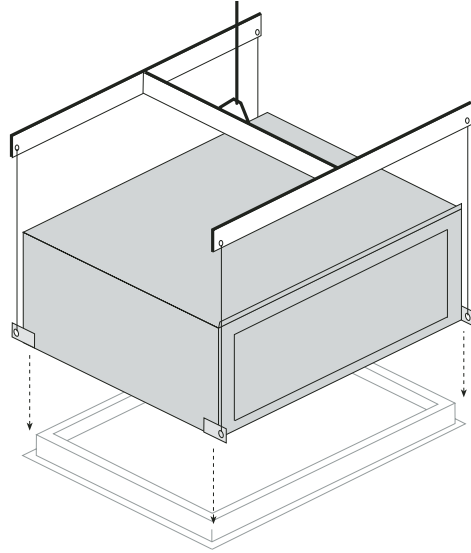

I - 4

### NOTE!

The use of all lifting lugs and a set of spreader bars is mandatory when lifting the unit.

### NOTE!

For easy installation, it is recommended that the weatherhood, filter section or evaporative cooler be installed after the base unit.

## Step 5 Install Ductwork

If the unit has a downblast (DB) discharge, the ductwork was installed in step 2.

If the unit has a horizontal (HZ) discharge, apply an appropriate sealant around the discharge of the unit to create a weather tight seal. Then using sheet metal screws, attach the ductwork to the unit.

Good duct practices should be followed for all ductwork. All ductwork should be installed in accordance with SMACNA and AMCA guidelines, NFPA 96 and all local codes. Refer to the CAPS submittal for the ductwork sizes.

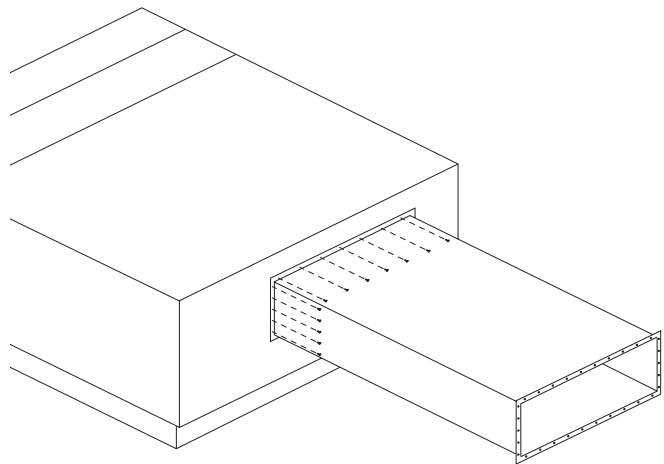

# Installation - Filter Section and Weatherhood

## NOTE!

Installation instructions for the filter section and weatherhood apply only to non-evaporative cooling units. For evaporative cooling units, skip to the evaporative cooler installation instructions.

### Step 1 Apply Sealant

Apply an appropriate sealant around the intake end of the base unit to create a weather tight seal.

### Step 2 Install Filter Section

Use a crane and a set of spreader bars hooked to the factory lifting lugs to lift and center the filter section on the intake end of the base unit. The flange along the top of the filter section should overlap the flange along the top of the base unit.

Use self-tapping sheet metal screws to fasten the filter section to the base unit across the top and down the sides.

If filters are not installed in the filter section, install them now. Airflow arrows are located on the filters to ensure proper installation.

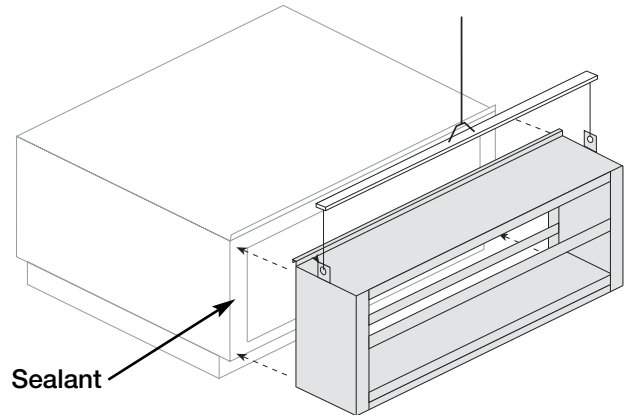

1-5

## NOTE!

The use of all lifting lugs and a set of spreader bars is mandatory when lifting the filter section.

### Step 3 Apply Sealant

Apply an appropriate sealant around the intake end of the filter section to create a weather tight seal.

### Step 4 Install Weatherhood

Use a crane and a set of spreader bars hooked to the factory lifting lugs to lift and center the assembled weatherhood on the intake end of the base unit. The flange along the top of the weatherhood should overlap the flange along the top of the filter section.

Use self-tapping sheet metal screws to fasten the weatherhood to the filter section across the top and down the sides.

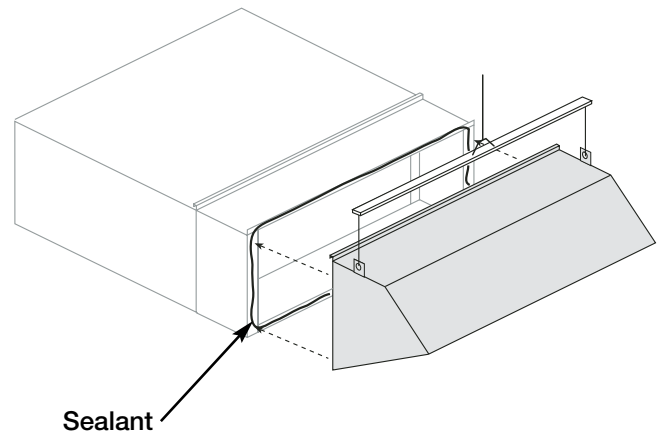

## NOTE!

The use of all lifting lugs and a set of spreader bars is mandatory when lifting the weatherhood.

### Step 5 Install Inlet Air Sensor (Optional)

If the unit is equipped with an inlet air sensor, the sensor may need to be installed. The sensor and tubing can be found bundled inside the control center of the unit. The sensor should be installed inside of the weatherhood with the tubing run inside of the unit.

# Installation - Evaporative Cooler (Optional)

## Step 1 Locate Equipment Support(s)

Position equipment support(s) on the roof (refer to the CAPS submittal for the general location of the equipment support(s) in relation to the unit). Verify that all unit supports are level, shim if necessary. Equipment supports are supplied by others and not supplied by Greenheck.

## Step 2 Install Evaporative Cooling Module

1-6

Use a crane and a set of spreader bars hooked to the factory lifting lugs to lift and center the evaporative cooling module on the equipment support(s). The flange along the top of the evaporative cooler should overlap the flange along the top of the base unit.

### NOTE!

When mounting the evaporative cooler, it is important that it is level to ensure proper operation and water drainage.

### NOTE!

The use of all lifting lugs and a set of spreader bars is mandatory when lifting the evaporative cooling module.

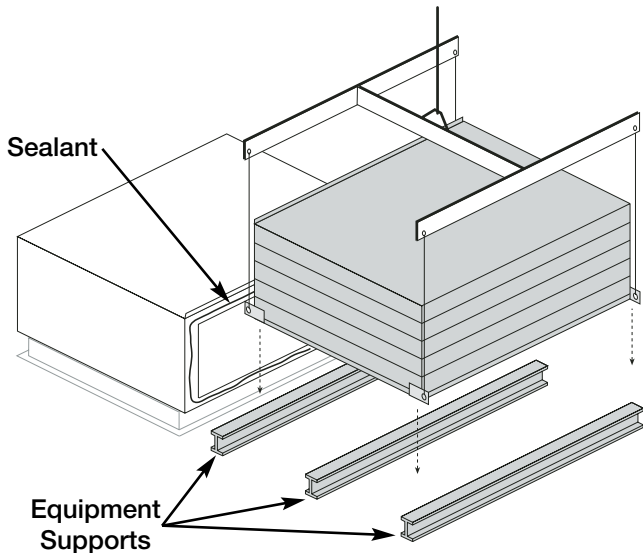

## Step 3 Secure Cooling Module to Unit

Use self-tapping screws to fasten the cooling module to the base unit. The cooler should be fastened to the base unit across the top and down both sides.

To fasten along the top, run fasteners through the flange joining the two sections.

To fasten the sides, from inside the unit, run fasteners down both sides of the opening between the base unit and the evaporative cooler.

## Step 4 Install Inlet Air Sensor (Optional)

If the unit is equipped with an inlet air sensor, the sensor may need to be installed. The sensor and tubing can be found bundled inside the control center of the unit. The sensor should be installed inside of the louvered intake, upstream and clear of the evaporative cooling media. The tubing should be run inside of the unit.

## Step 5 Connect Dirty Filter Switch (Optional)

If a dirty filter switch is located in the control center, connect the low pressure tap on the dirty filter switch to the low pressure tap inside the junction box on the evaporative cooler. Tubing is included in the control center.

# Installation - Evaporative Cooling Piping (Optional)

## Evaporative Cooling with Recirculating Pump.

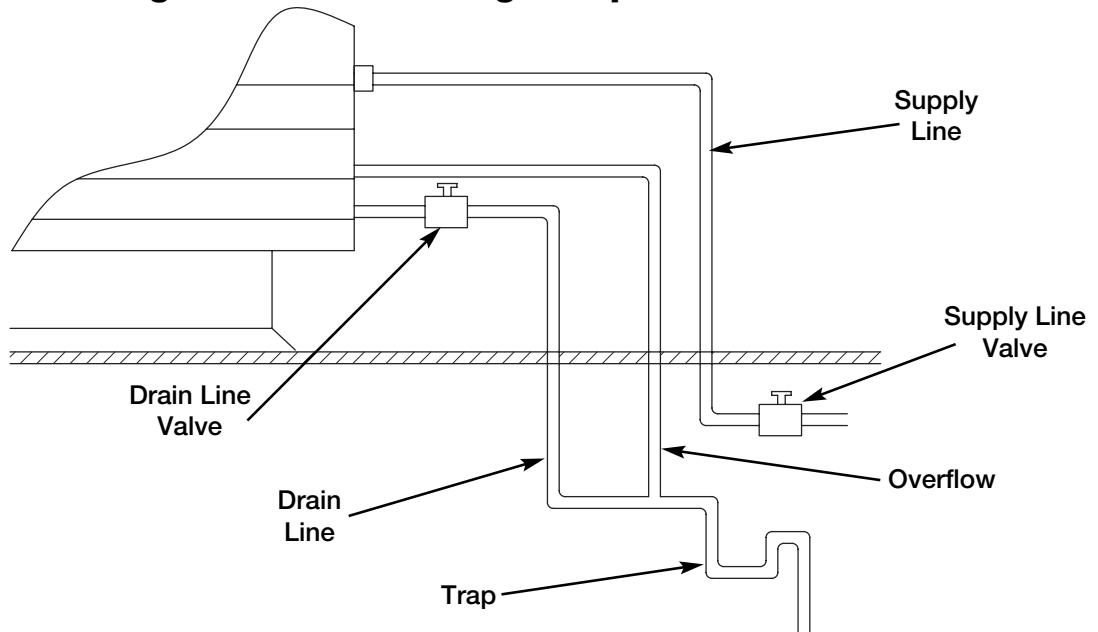

**IMPORTANT!**  
All solenoids, valves and all traps must be below the roofline or be otherwise protected from freezing.

**IMPORTANT!**  
The supply line should be of adequate size and pressure to resupply the amount of water lost due to bleed-off and evaporation. The drain line should be the same size or larger than the supply line.

**CAUTION!**  
Provisions must be taken to prevent damage to the evaporative cooling section during freezing conditions. The sump, drain lines and supply lines must be drained prior to freezing conditions or an alternate method must be used to protect the lines and media.

### Step 1 Install the Water Supply Line

Connect the water supply line to the float valve in the evaporative cooling unit. Install a manual shutoff valve in the supply line as shown above.

### Step 2 Install the Drain Line

Connect an unobstructed drain line with a manual shut-off valve from the sump drain to the main drain line as shown above. Install a drain line from the sump overflow to the drain line. A trap (as shown to the right) should be used to prevent sewer gas from being drawn into the unit.

### Step 3 Check/Adjust Water Level

Check the water level in the sump tank. The water level should be above the pump intake and below the overflow. Adjust the float as needed to achieve the proper water level.

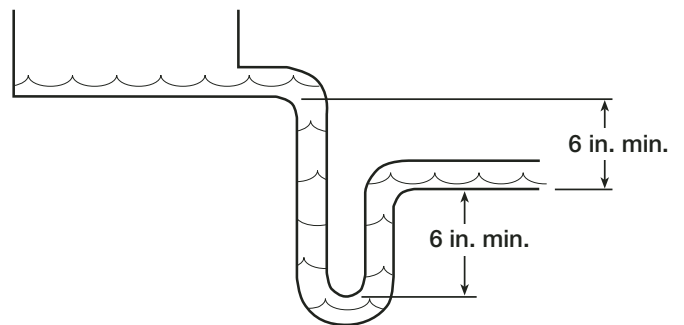

# Installation - Evaporative Cooling Piping (Optional)

## Evaporative Cooling with Auto Drain and Fill

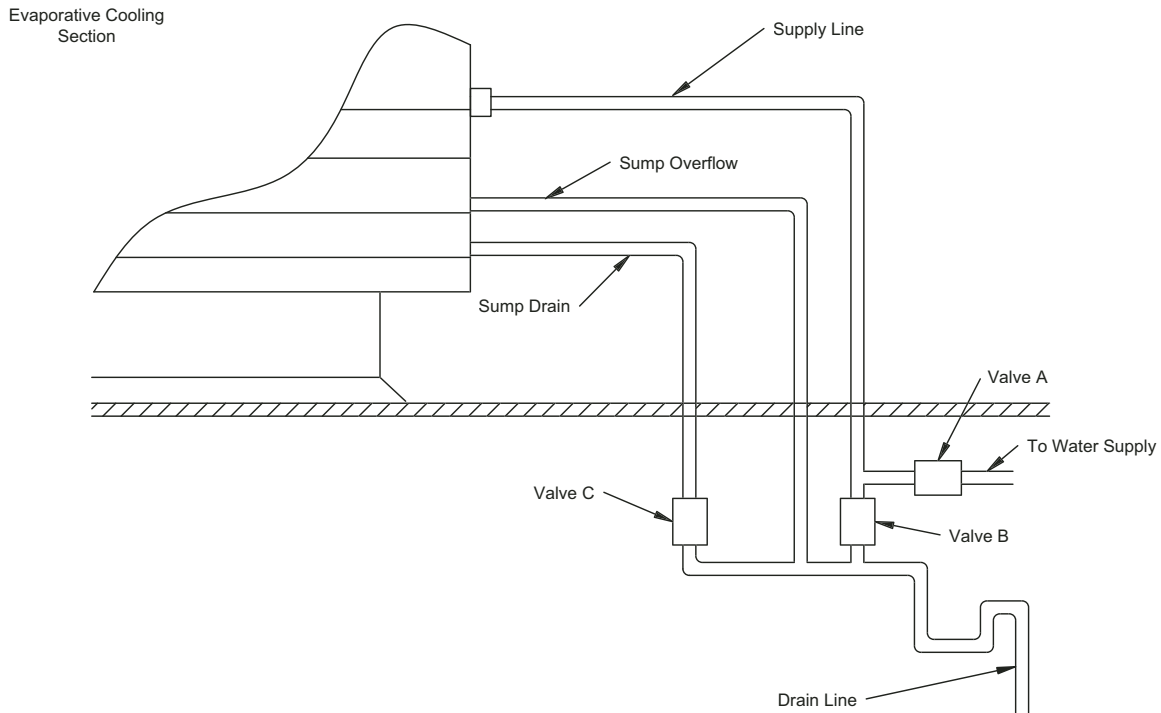

1 - 8

### IMPORTANT!

The supply line should be of adequate size and pressure to resupply the amount of water lost due to bleed-off and evaporation. The drain line should be the same size or larger than the supply line.

### CAUTION!

All solenoids, valves and traps must be installed below the roof to protect the supply water line from freezing. If they cannot be installed below the roof, an alternative method must be used to protect the lines from freezing.

### IMPORTANT!

The supply solenoid (Valve A) is NOT the same as the drain solenoids (Valve B and Valve C). Make sure to use the proper solenoid for each location. Check your local code requirements for proper installation of this type of system.

### Step 1 Install the Water Supply Line

Connect the water supply line to the float valve in the unit. Install the 1/2 in. normally closed solenoid (Valve A) in the supply line as shown above. Install the 1/4 in. normally open solenoid (Valve B) between the supply line and the drain line as shown above.

### Step 2 Install the Drain Line

Connect an unobstructed drain line to the sump drain. Install the 3/4 in. normally open solenoid (Valve C) between the sump drain connection and the drain line. A trap (as shown to the right) should be used to prevent sewer gas from being drawn into the unit.

### Step 3 Check/Adjust Water Level

Check the water level in the sump tank. The water level should be above the pump intake and below the overflow. Adjust the float as needed to achieve the proper water level.

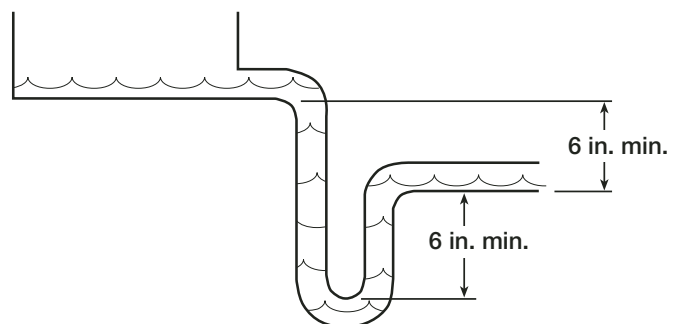

# Installation - Water Wizard (Optional)

## Evaporative Cooling with the Water Wizard

### NOTE!

The following instructions are provided for evaporative coolers equipped with the Water Wizard only.

### WARNING!

Disconnect and lock-out all power and gas before performing any maintenance or service to the unit. Failure to do so could result in serious injury or death and damage to equipment.

### Step 1 Install Supply Line/Solenoid

Connect the water supply line to the manual supply valve in the unit. Install the supply solenoid in the supply line, upstream of the manual supply valve and below the roofline.

### Step 2 Install Drain Line/Solenoid

Connect the drain line to the supply line between the manual supply valve and the supply solenoid. Install a drain solenoid in the drain line, below the roof line. A trap (as shown to the right) should be installed in the drain line.

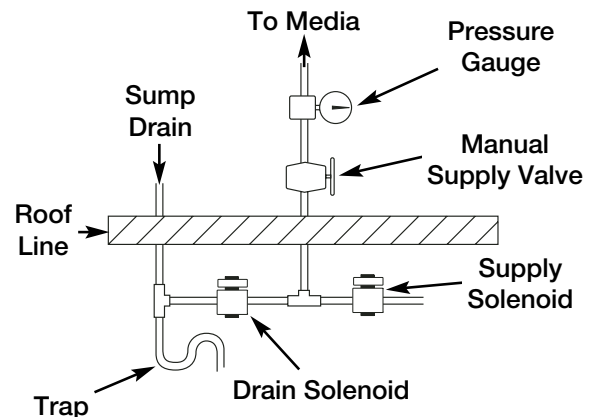

### NOTE!

Solenoid(s) may be provided by Greenheck (if ordered) or by others.

### CAUTION!

Any wiring deviations may result in personal injury or property damage. Greenheck is not responsible for any damage to, or failure of the unit caused by incorrect final wiring.

### Step 3 Wire the Solenoid(s)

Wire the supply solenoid to terminals X and 25 in the control center. Wire the drain solenoid to terminals X and 26 in the control center.

### Step 4 Wire the Temperature Sensor

The temperature sensor must be wired. The sensor wire is bundled inside the discharge end of the evaporative cooler. Wire the sensor wire to terminals A/2 and A/C on the terminal strip in the unit's control center.

### NOTE!

The Water Wizard start-up must be completed for proper performance.

# Installation - Electrical Wiring

## IMPORTANT!

Before connecting power to the unit, read and understand the following instructions and wiring diagrams. Complete wiring diagrams are attached to the inside of the control center door(s).

## IMPORTANT!

All wiring should be done in accordance with the latest edition of the National Electric Code ANSI/NFPA-70 and any local codes that may apply. In Canada, wiring should be done in accordance with the Canadian Electrical Code.

I-10

## CAUTION!

If replacement wire is required, it must have a temperature rating of at least 105°C, except for energy cut-off or sensor lead wire which must be rated to 150°C.

## IMPORTANT!

The equipment must be properly grounded.  
Any wiring running through the unit in the airstream must be protected by metal conduit, metal clad cable or raceways.

## DANGER!

High voltage electrical input is needed for this equipment. This work should be performed by a qualified electrician.

## CAUTION!

Any wiring deviations may result in personal injury or property damage. Greenheck is not responsible for any damage to, or failure of the unit caused by incorrect final wiring.

## IMPORTANT!

Greenheck's standard control voltage is 24 VAC.  
Control wire resistance should not exceed 0.75 ohms (approximately 285 feet total length for 14 gauge wire; 455 feet total length for 12 gauge wire). If the resistance exceeds 0.75 ohms an industrial-style, plug-in relay should be wired in place of the remote switch. The relay must be rated for at least 5 amps and have a 24 VAC coil. Failure to comply with these guidelines may cause motor starters to chatter or not pull in, resulting in contactor failures and/or motor failures.

### Step 1 Determine the Size of the Main Power Lines

The unit nameplate states the voltage and the unit's total amps. The main power lines to the unit should be sized accordingly.

Unit's Total Amps		Voltage, Hertz, and Phase	
MODEL	<input type="text"/>	<input type="text"/>	<input type="text"/>
VOLTS	<input type="text"/>	HTZ	<input type="text"/>
AMPS	<input type="text"/>	S/N	<input type="text"/>
SUP HP	<input type="text"/>	EXH HP	<input type="text"/>
MARK	<input type="text"/>		

# Installation - Electrical Wiring

## Step 2 Provide the Opening(s) for the Electrical Connections

Electrical openings vary by unit size and arrangement and are field supplied.

## Step 3 Connect the Main Power

Connect the main power lines to the disconnect switch and main grounding lug(s). Torque field connections to 20 in-lbs. See the control center layout in the reference section for main disconnect and grounding lug(s) locations.

## Step 4 Wire the Optional Convenience Outlet

The convenience outlet requires a separate 115V power supply circuit. The circuit must include short circuit protection which may need to be supplied by others.

## Step 5 Wire the Accessories

Reference the ladder diagram on the inside of the control center door for correct wiring of the following accessories:

- Selectrastat
- Room Override
- Blower Switch
- Heat Switch
- Indicating Lights
- Dirty Filter Indicator
- TSCP

### NOTE!

Wiring to the Selectrastat, Maxitrol 14 (discharge temperature selector) or 44 (room override) should be in separate conduit or run with shielded cable.

### NOTE!

TSCP has number-to-number wiring.

# Installation - Electrical Wiring

## Step 6 Wire the Optional Evaporative Cooler

Reference the ladder diagram on the inside of the control center door for correct wiring of the optional pump and the optional auto-drain and flush. Wiring instructions for the optional Water Wizard are included in the Water Wizard installation instructions.

### NOTE!

Large evaporative coolers may require a separate power supply.

I-12

## Step 7 Check Recirculation / VAV Operation

### NOTE!

Blower start-up (S-1), steps 1-4 should be performed before the blower is run.

### Two Position Damper Control

Turn the recirculating switch on the remote control panel to each position and confirm that the return air damper adjusts accordingly. The damper actuator may take a few minutes to open or close.

### Two Speed

Turn the fan speed switch on the remote control panel to each position and confirm that the fan speed adjusts accordingly

### Potentiometer Control

To test potentiometer operation, turn the potentiometer to the two extremes. With 80/20 recirculation, confirm that the return air damper fully opens and fully closes. The damper actuator may take a few minutes to open or close. With variable volume, make sure the fan goes to maximum and minimum speed.

### Building Pressure Control

See I-15 for building pressure set-up and operation check.

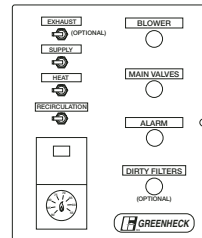

2-Position Damper Control

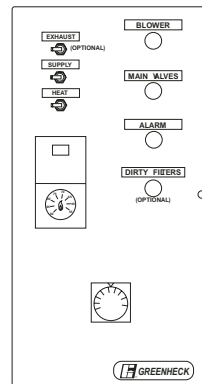

Potentiometer Control

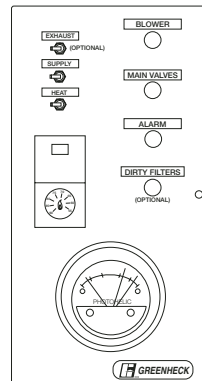

Building Pressure Control

### NOTE!

For maintenance issues associated with variable frequency drives, consult the drive's manual supplied with the unit. The drives are programmed at the factory and should not need any adjustment during installation and start-up. For kitchen applications, the drive may be located in the kitchen or in the unit.

# Installation - Direct Gas Piping

## IMPORTANT!

All gas piping must be installed in accordance with the latest edition of the National Fuel Gas Code ANSI/Z223.1 and any local codes that may apply. In Canada, the equipment shall be installed in accordance with the Installation Code for Gas Burning Appliances and Equipment (CGA B149) and Provincial Regulations for the class. Authorities having jurisdiction should be consulted before installations are made.

## WARNING!

All components of this or any other gas-fired heating unit must be leak tested prior to placing the unit into operation. A soap and water solution should be used to perform this test. NEVER test for gas leaks with an open flame.

## WARNING!

If pressure testing in excess of 1/2 psig (3.5 kPa), the heater and manual shutoff valve must be disconnected from the supply gas line.

## WARNING!

If pressure testing at or below 1/2 psig (3.5 kPa), the heater must be isolated from the supply gas line by closing its manual shutoff valve.

## IMPORTANT!

All piping should be clean and free of any foreign matter. Foreign material entering the gas train can damage the valves, regulators and burner.

## IMPORTANT!

Do NOT connect the unit to gas types other than what is specified and do NOT connect the unit to gas pressures that are outside of the pressure range shown on the label.

## Step 1 Determine the Supply Gas Requirements

The unit's direct gas nameplate states the requirements for the gas being supplied to the unit.

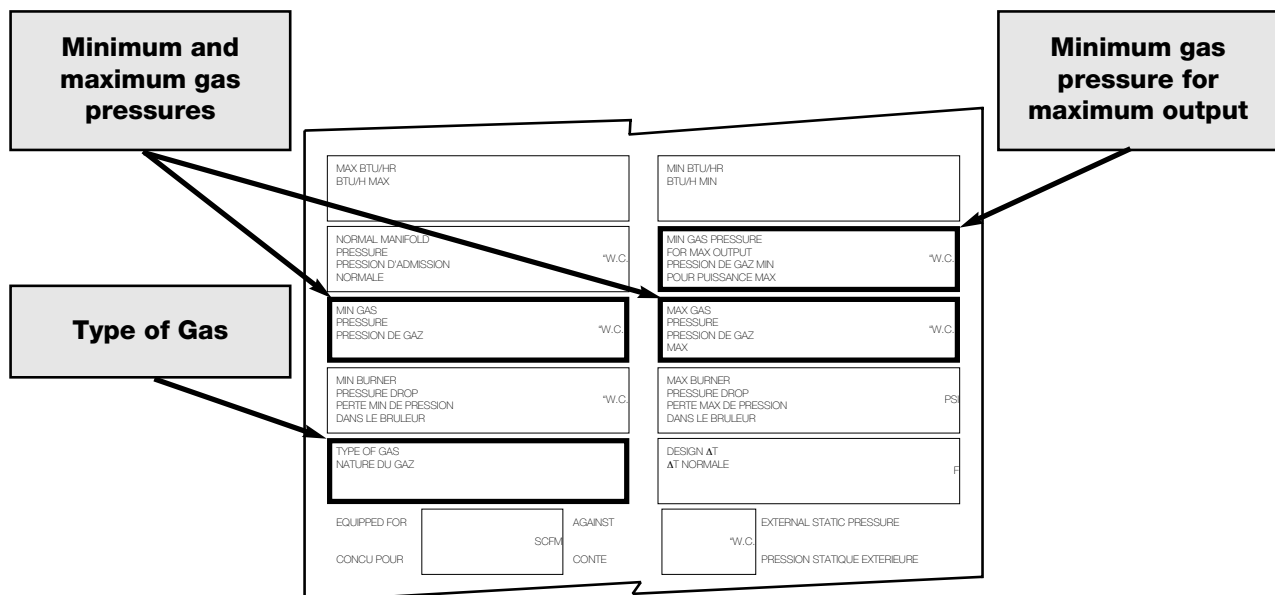

# Installation - Direct Gas Piping

## Step 2 Install Additional Regulator if Required

If the supply gas pressure exceeds the maximum gas pressure shown on the direct gas nameplate, an additional regulator (by others) is required to reduce the pressure. The regulator must have a listed leak limiting device or it must be vented to the outdoors.

### NOTE!

The regulator located inside the unit is used to adjust the unit's maximum output temperature.

I-14

## Step 3 Connect the Supply Gas Line

A manual shut off valve (gas cock), 1/8 in. plugged test port and 6 in. drip leg must be installed prior to the gas train. The valve and test port must be accessible for the connection of a test gauge. Supply gas connections must be made by a qualified installer and are not furnished by Greenheck.

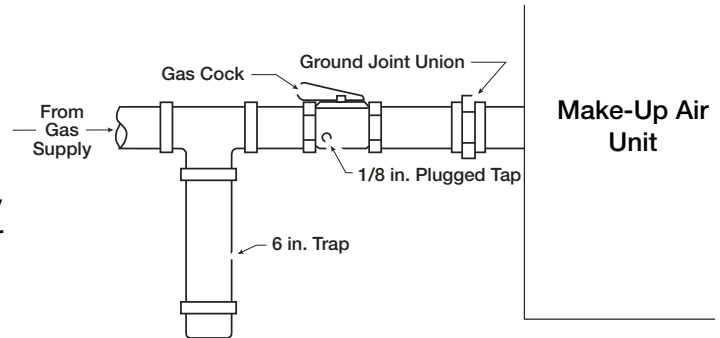

## Step 4 Pipe the Optional Vent Line

If an optional vent line is located between the safety shutoff valves it must be piped to the outdoors.

### NOTE!

Reference the National Fuel Gas Code for additional vent line requirements.

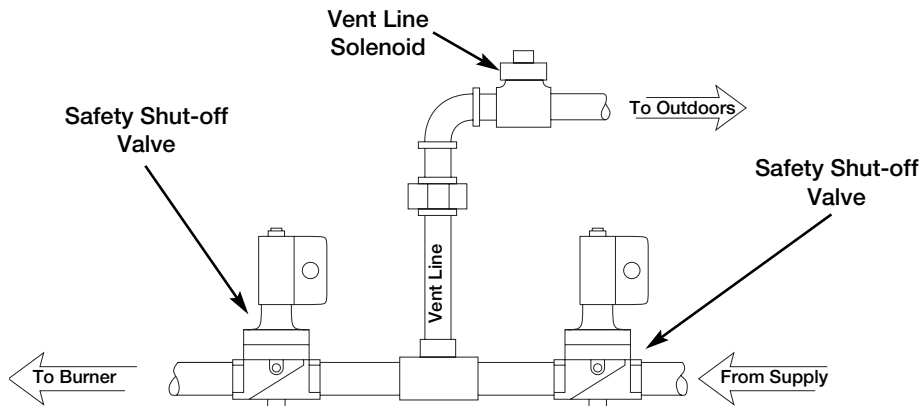

## Step 5 Test the System for Leaks

Check both the supply lines and the factory piping for leaks. Apply a soap and water solution to all piping and watch for bubbling which indicates a leak.

### WARNING!

NEVER test for a gas leak with an open flame.

### WARNING!

The factory piping has been checked for leaks, but should be rechecked due to shipping and installation.

# Installation - Building Pressure Control (Optional)

## Step 1 Mount Pressure Tap

Using the factory provided bracket, mount the pressure tap to the outside of the unit. Choose a location out of the prevailing winds and away from supply or exhaust fans to assure accurate readings.



## Step 2 Run Pressure Tap Lines

A pressure tap line must be run from the pressure tap mounted on the outside of the unit to the low pressure tap on the back of the photohelic gauge. A second pressure tap line must be run from the high pressure tap on the back of the photohelic to the space. Fifty feet of tubing is supplied with the unit.

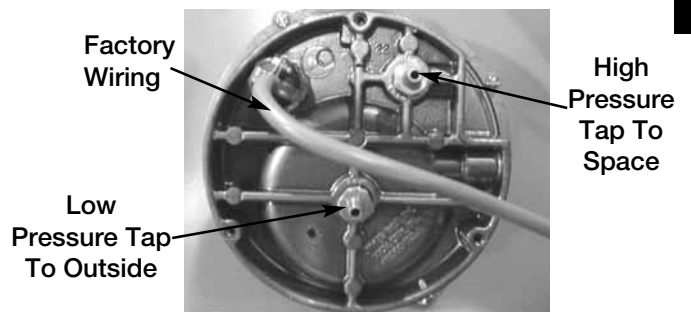

## Step 3 Set the Building Pressure

The pressure gauge (pictured bottom right) is used to set the desired building pressure. The pressure is set by adjusting the knobs for the upper and lower pressure limits. Typical settings are 0.0 in. wc for the lower and 0.10 in. wc for the upper pressure setting.

## Step 4 Check Control System

### NOTE!

Blower start-up (S-1), steps 1-4 should be performed before the blower is run.

Before the unit is left in service, the recirculation control system should be tested. This can be accomplished by turning both knobs to the upper most pressure setting. You may have to remove the outdoor pressure tap tubing. The return air damper should close (VAV systems should go to max speed). Then set both knobs at the lowest setting, and the damper should open (VAV systems should go to minimum speed). It may take one to two minutes for the damper to reach the desired position.

Reset the correct pressure limits before starting the unit.

The picture on the bottom right shows a typical photohelic setting. The needle in this photo indicates a negative building pressure. During correct operation the indicating needle will remain between or near the setting needles.

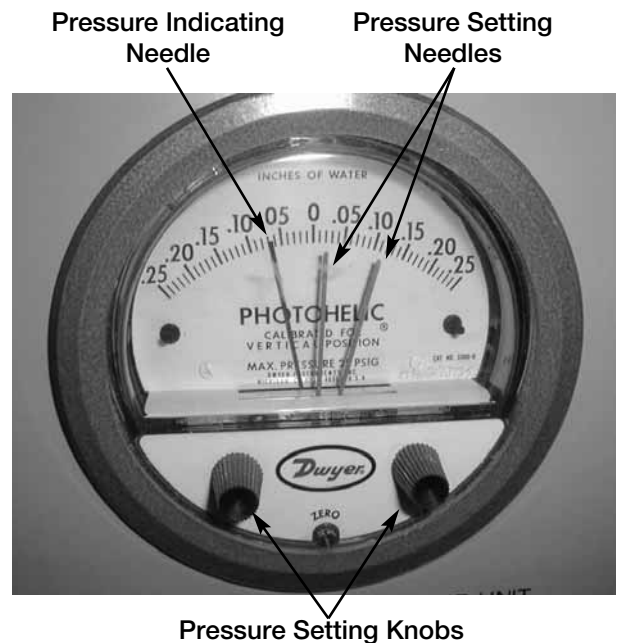

# Start-Up - Blower

## Pre-Start-Up Check

Rotate the fan wheel by hand and make sure no parts are rubbing. Check the V-belt drive for proper alignment and tension (a guide for proper belt tension and alignment is provided in the belt maintenance section). Check fasteners, set screws and locking collars on the fan, bearings, drive, motor base and accessories for tightness. Remove any shipping fasteners from the blower vibration isolators.

**WARNING!**  
Disconnect and lock-out all power and gas before performing any maintenance or service to the unit. Failure to do so could result in serious injury or death and damage to equipment.

## SPECIAL EQUIPMENT REQUIRED

Below is a list of special tools that are required. A recommended model is shown, but equivalent products may be used.

Description	Manufacturer-Model	Phone	Website
Voltage Meter	Fluke-23	1-800-44-FLUKE	www.fluke.com
Amperage Meter	Fluke-23	1-800-44-FLUKE	www.fluke.com
Thermometer	Fluke-50	1-800-44-FLUKE	www.fluke.com
U-Tube manometer	Dwyer-Slack Tube	1-219-897-8000	www.dwyer-inst.com
Tachometer	Monarch-Pocket Tach 100	1-800-999-3390	www.monarchinstruments.com

## WARNING!

Check the housing, evaporative cooler, blower, weatherhood, filter section and ductwork for foreign objects and debris before the blower is run.

## Step 1 Check the Voltage

Before starting the unit, compare the supplied voltage, hertz, and phase with the unit and motor's nameplate information.

**Voltage, Hertz, and Phase**

MODEL	<input style="width: 100%;" type="text"/>		
VOLTS	<input style="width: 40px;" type="text"/>	Hz	<input style="width: 40px;" type="text"/>
AMPS	<input style="width: 100px;" type="text"/>	S/N	<input style="width: 100px;" type="text"/>
SUP HP	<input style="width: 100px;" type="text"/>	EXH HP	<input style="width: 100px;" type="text"/>
MARK	<input style="width: 100%;" type="text"/>		

## Step 2 Check the Blower Rotation

Open the blower access door and run the blower momentarily to determine the rotation. Arrows are placed on the blower scroll to indicate the proper direction or reference the example below.

**NOTE!**  
To reverse the rotation on three phase units, disconnect and lock-out the power, then interchange any two power leads.

**NOTE!**  
To reverse the rotation on single phase units, disconnect and lock-out the power, then rewire the motor per the manufacturer's instructions.

**IMPORTANT!**  
If the blower is rotating in the wrong direction, the unit will move some air, but will not perform as designed. Be sure to perform a visual inspection to guarantee the correct blower rotation.

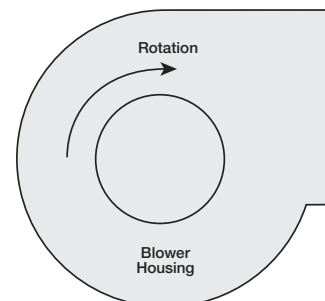

# Start-Up - Blower

## Step 3 Check for Vibration

Check for unusual noise, vibration or overheating of the bearings. Reference the troubleshooting section for corrective actions.

### IMPORTANT!

Excessive vibration may be experienced during the initial start-up. Left unchecked, it can cause a multitude of problems including structural and/or component failure.

### IMPORTANT!

Generally, fan vibration and noise is transmitted to other parts of the building by the ductwork. To minimize this undesirable effect, the use of heavy canvas duct connectors is recommended.

## Step 4 Motor Check

Measure the motor voltage, amps and RPM and compare to the specifications on the motor nameplate. Check the overload setting and make sure it matches the motor's amperage rating. If the motor's actual amps are greater than the nameplate amps, check and correct the supply voltage or air volume of the blower.

### NOTE!

Additional starters and overloads may be provided in the make-up air control center for optional exhaust blowers. Any additional starters and overloads must also be checked for proper voltage, amps and RPM's.

## Step 5 Air Volume Measurement and Check

Measure the unit's air volume (CFM) and compare it with its rated air volume. If the air volume is off, adjust the fan RPM by changing the drive.

### NOTE!

The most accurate way to measure the air volume is by using a pilot traverse method downstream of the blower. Other methods can be used but should be proven and accurate.

### IMPORTANT!

Changing the air volume can significantly increase the motor's amps. If the air volume is changed, the motor amps must be checked to prevent overloading the motor.

## Step 6 Set-up Optional Components

Adjust the settings on the optional components. See the control center layout in the reference section for location of optional components.

- Heating Inlet Air Sensor (typical setting: 60-70°F)
- Cooling Inlet Air Sensor (typical setting: 75°F)
- Building Freeze Protection (typical setting: 5 min at 45°F)
- Dirty Filter Gauge (typical setting: settings vary greatly for each unit)
- Solid Fuel Time Delay (typical setting varies per application)

# Start-Up - Direct Gas

## IMPORTANT!

For proper unit function and safety, follow the start-up procedure in the exact order that it is presented.

## IMPORTANT!

This start-up should begin after all of the installation procedures and the blower start-up have been completed.

### Step 1 Check the Supply Gas Pressure

Check the supply gas pressure and compare it with the unit's nameplate pressure requirements. Adjust the supply regulator as needed until the supply gas pressure is within the specified range.

S - 3

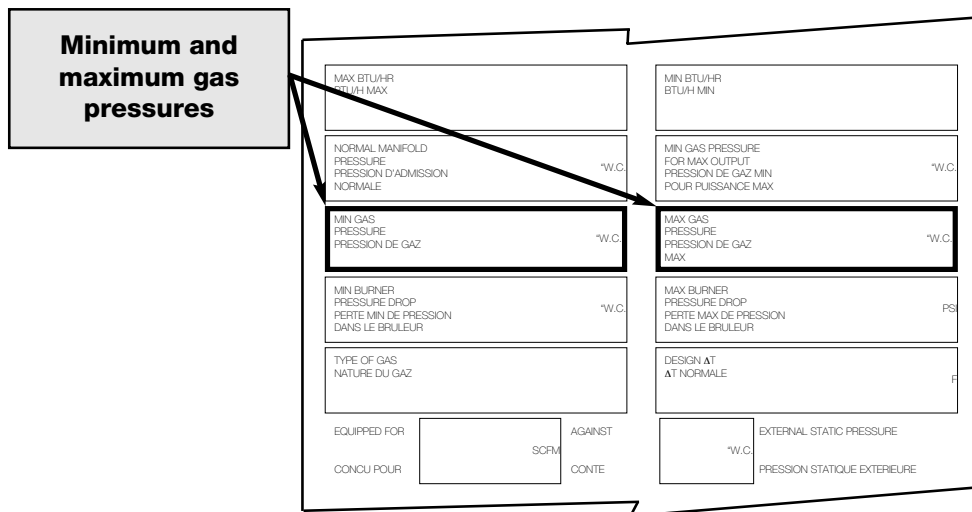

### Step 2 Check the Pilot Gas Pressure

Check the pilot gas pressure. The recommended gas pressure is 3 in. wc. Adjust the pilot regulator as needed. See the gas train layout in the reference section for the location of the pilot pressure test port and pilot regulator.

### Step 2 Check the Optional High and Low Gas Pressure Switches

Check the settings on the high and low gas pressure switches. The high pressure setting is typically 8 in. wc and the low pressure setting is typically 3 in. wc. The switches are set at the factory and should not need adjustment. Adjust the setting only if needed. See the gas train layout diagram in the reference section for the high and low pressure switch location.

## NOTE!

The purpose of the high and low gas pressure switches is to automatically shut down the burner if the inlet gas pressure is too low for the burner to safely light or if the manifold pressure is too high for the burner to operate properly.

# Start-Up - Direct Gas

**IMPORTANT!**  
Proper air velocity over the burner is critical on direct fired gas units. If the air velocity is not within the unit specifications, the unit will not operate efficiently, may have sporadic shutdowns and may produce excessive carbon monoxide (CO) or other gases.

## Step 4 Set the Burner Air Pressure Differential

With the fan running and discharging 70°F air, connect a U-Tube manometer to the outer sensing probes (see below) and measure the static pressure across the burner.

The static pressure MUST be between 0.625 and 0.675 inches wc. Evenly adjust the baffles above and below the burner, keeping the burner centered in the opening until the required pressure is obtained.

**NOTE!**  
When required pressure is obtained be sure to reconnect the outer sensing probes.

**IMPORTANT!**  
This process may need to be repeated until the proper pressure is achieved. This adjustment will change the air quantity delivered by the unit and therefore the air quantity delivered should be rechecked. Refer to the blower start-up section.

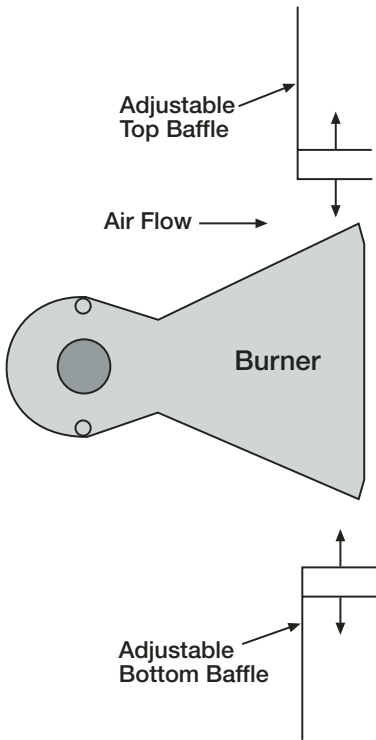

**NOTE!**  
To increase the static pressure decrease the opening. To decrease the static pressure increase the opening.

S - 4

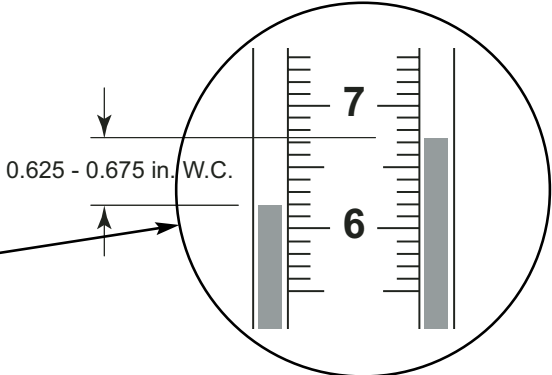
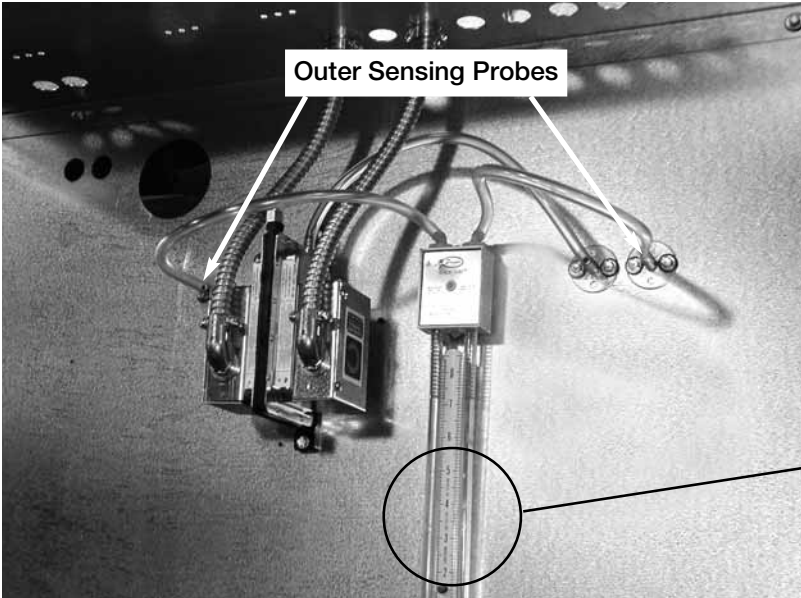

# Start-Up - Direct Gas

## Step 5 Set the Low Fire Time Delay

Set the low fire time delay to 75% of its maximum setting. See the drawings below for the location of the time delay setting.

## Step 6 Set the Maximum Firing Rate

Monitor the unit's actual temperature rise by placing a thermocouple in the unit's inlet and a second in the discharge, three duct diameters downstream of the burner.

Send the unit to high fire by disconnecting and isolating the proper wire on the Maxitrol amplifier. (Terminal #4 for Maxitrol 14, #3 for Maxitrol 44 as shown below).

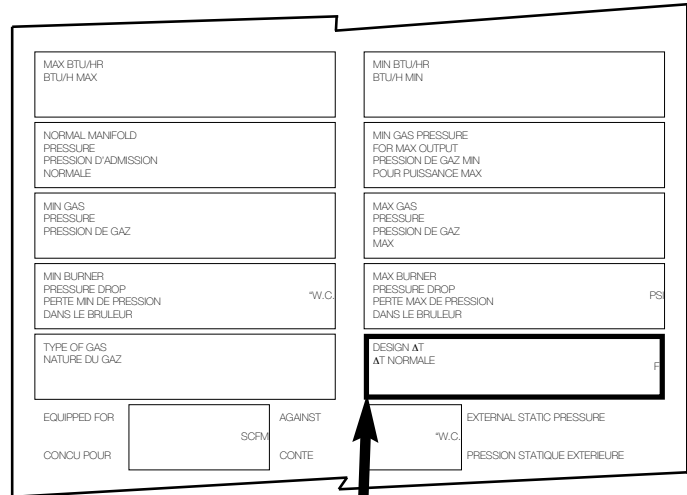

### WARNING!

Do not set the burner maximum firing rate based on gas pressure. It should be set based on the unit's designed temperature rise shown on the direct gas label.

S-5

Continues on next page...

## Maxitrol Series 14

(7 terminals)

## Maxitrol Series 44

(9 terminals)

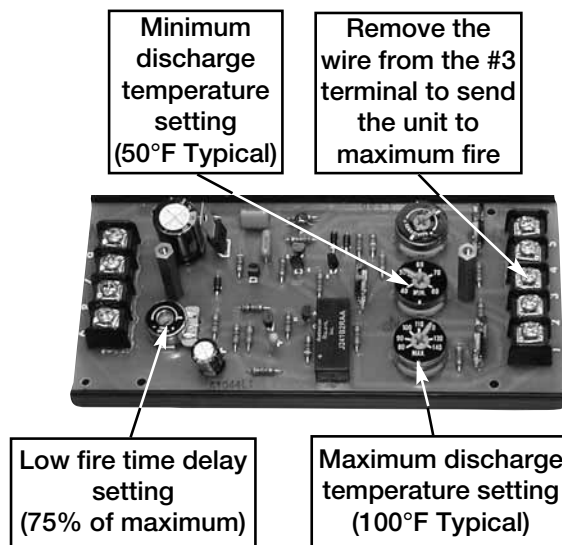
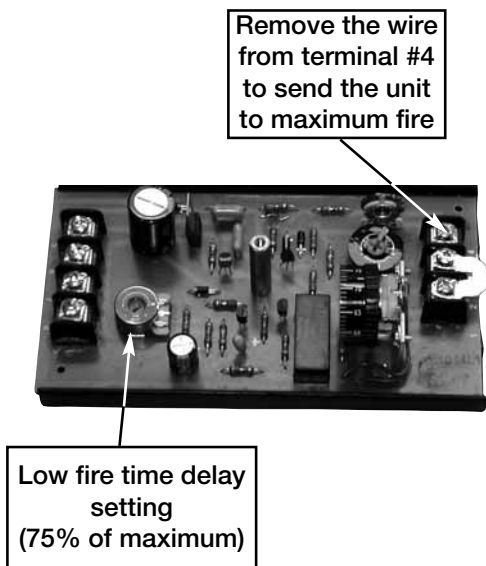

# Start-Up - Direct Gas

## Step 6 Set the Maximum Firing Rate (...continued)

While monitoring the units temperature rise, set the maximum firing rate by adjusting the regulator (as shown below) until the desired temperature rise is achieved. After setting the maximum firing rate, reconnect the wire to the amplifier.

### IMPORTANT!

Setting the maximum firing rate during mild weather conditions may cause the high limit to trip out during extreme conditions requiring manual resetting.

### NOTE!

The minimum setting for the maximum firing rate may be higher than required. This is acceptable, the burner will modulate as needed.

### NOTE!

Gas trains are equipped with either separate regulators and modulating valves or with a combined modulating regulator.

## Separate Regulator and Modulating Valve

Remove cap to access maximum firing rate adjustment

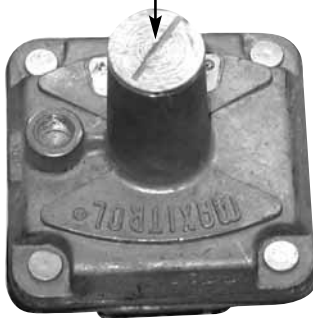

## Combined Modulating Regulator

Maximum firing rate adjustment

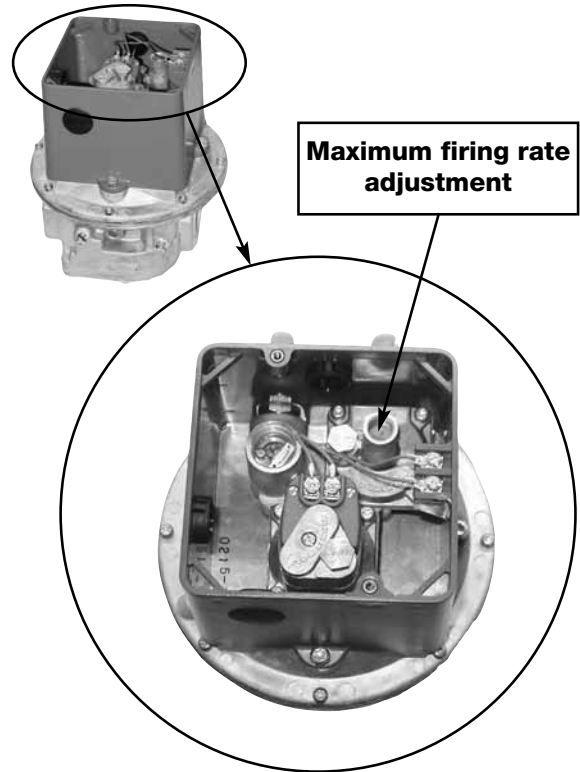

### NOTE!

Clockwise rotation increases the temperature rise, counterclockwise rotation decreases the temperature rise.

# Start-Up - Direct Gas

## Step 7 Set the Minimum Firing Rate

Disconnect and isolate one of the wires running to the modulating valve to send the unit to its minimum firing rate. Set the minimum firing rate by adjusting the needle valve as shown in the figures below.

After setting the minimum firing rate, shut off the pilot to ensure that the flame safe guard can still read the main flame signal. Reconnect the wire to the modulating valve and open the pilot shut-off valve.

### IMPORTANT!

The proper setting for the minimum firing rate results in a small ribbon of continuous flame across the entire burner.

### IMPORTANT!

Do not allow the disconnected wire to come in contact with a potential ground, damage to the amplifier or transformer could result.

### NOTE!

On units with a 42 inch or greater burner, the flame safe guard will automatically shut off the pilot after the burner has been ignited.

### NOTE!

Gas trains are equipped with either separate regulators and modulating valves or with a combined modulating regulator.

### NOTE!

Adjusting the maximum and minimum firing rate requires the inlet air sensor to be set higher than the outside air temperature to start the burner(s). Once high and low fire have been set, the inlet air sensor should be set to the desired temperature.

S-7

## Separate Regulator and Modulating Valve

Remove one wire to send the unit to the minimum firing rate.

Minimum firing rate adjustment



### NOTE!

Counterclockwise rotation increases the minimum fire rate setting, clockwise rotation decreases the setting.

## Combined Modulating Regulator

Minimum firing rate adjustment

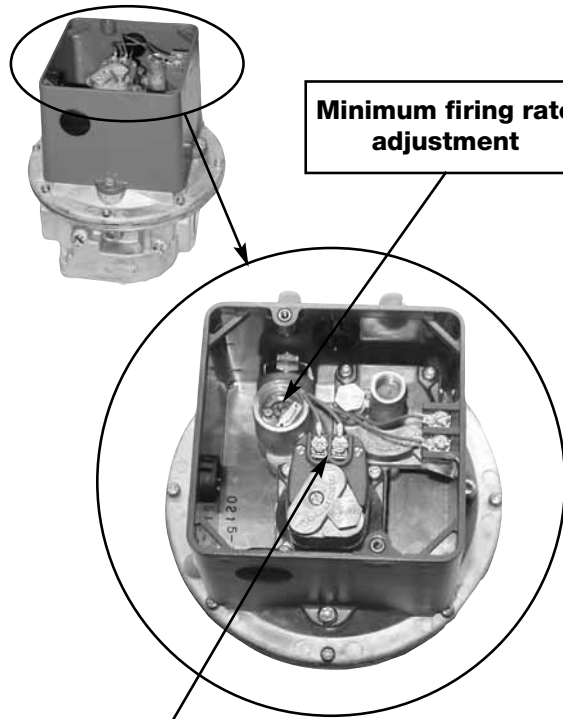

Remove one wire to send the unit to the minimum firing rate.

# Start-Up - Direct Gas

## Step 8 Set the Unit's Operating Temperature

Set the operating temperature. The operating temperature setting depends on which Maxitrol controller is used and the desired space temperature.

### Maxitrol Series 14 (Discharge temperature control)

#### IMPORTANT!

The Maxitrol Series 14 should be set to the desired discharge temperature. The temperature selector may be built into the amplifier or may be a stand-alone dial. The stand-alone dial may be mounted remotely.

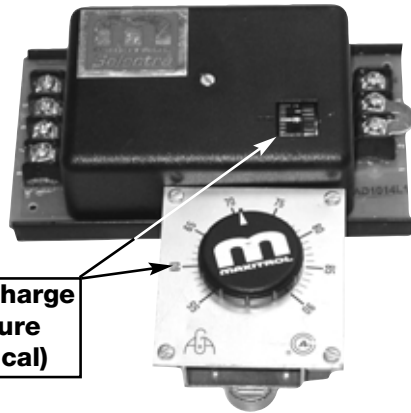

Set the discharge temperature  
(65°F Typical)

### Maxitrol Series 44 (Space temperature control)

#### IMPORTANT!

The Maxitrol Series 44 should be set to the desired room temperature. The Selectrstat must be mounted in the space.

Set the space temperature  
(70°F Typical)



S - 8

## Step 9 Flame Signal Check

To measure the flame signal connect a standard DC voltmeter to the flame amplifier test jacks + and - (com) as shown to the right. The flame signal should be above 1.25 VDC and steady.

Check the flame signal with the burner at pilot only, minimum fire, mid-fire and high-fire.

#### NOTE!

If the fame signal is not above 1.25 VDC and steady, consult the troubleshooting section.



# Start-Up - Evaporative Cooling (Optional)

## Step 1 Check the Installation

The media may have been removed during installation, so its orientation should be double checked. The media should be installed with the steeper flute angle sloping down toward the entering air side. See the figure on the right.

Verify that the stainless steel caps and distribution headers are in place. The headers should be located over the media towards the entering air side. The caps should be placed over the headers.

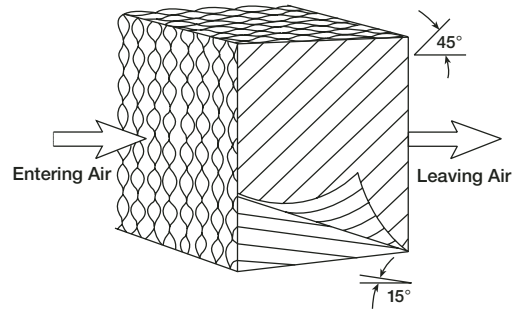

5-9

## Step 2 Check the Pump Filter

Check that the pump filter is around the pump inlet.

## Step 3 Fill the Sump and Adjust the Float

Turn on the water supply and allow the pan to fill. Adjust the float valve to shut-off the water supply when the sump is filled to within 1 in. of the bottom of the overflow.

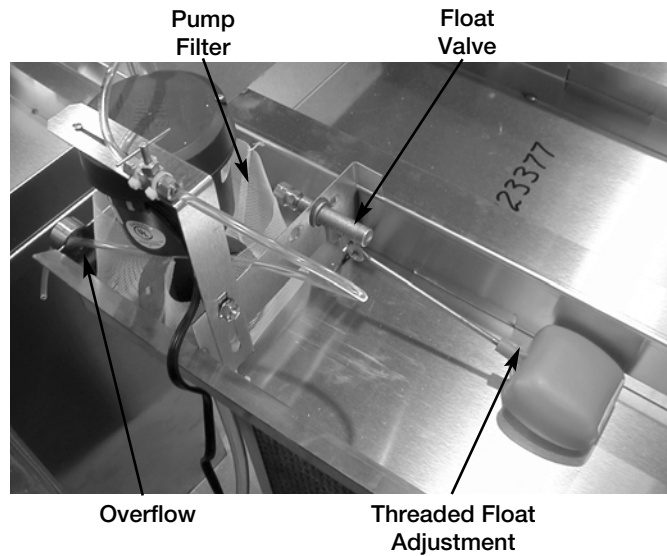

## Step 4 Break-in the Media

Open the bleed-off valve completely and saturate the media with the blower(s) off for no less than 20 minutes. A jumper will need to be installed in the control center to power the evaporative pumps with the blower(s) off. Reference the unit's ladder diagram to determine proper terminals.

## Start-Up - Evaporative Cooling (Optional)

### Step 5 Check the Flow Rate

The pumps should provide enough water to saturate the media in 45 to 60 seconds. Consult the factory, if adequate flow is not achieved.

### Step 6 Adjust the Water Bleed-Off Rate

The water bleed-off rate is dependent on the water's mineral content. The bleed-off should be adjusted based on media's mineral deposits after two weeks of service.

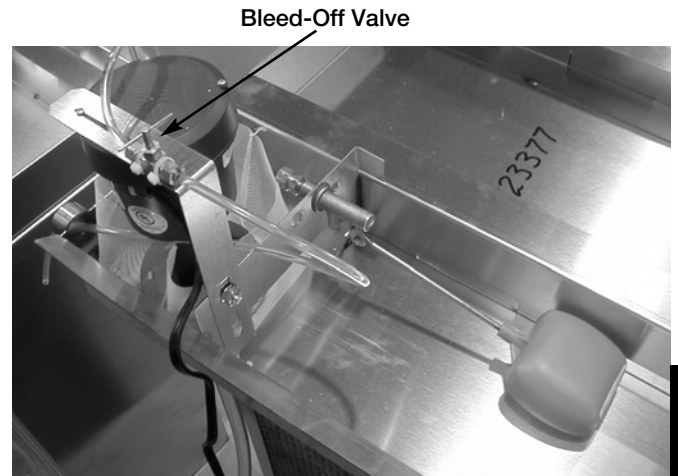

### Step 7 Set the Optional Auto Drain and Fill

Set the auto drain and fill timer and temperature settings. Timer settings are t1: 1.0, 10min and t2: 0.4, 60h. Temperature is typically set to 45°F.

Evaporative Freeze Protection



Evaporative Timer

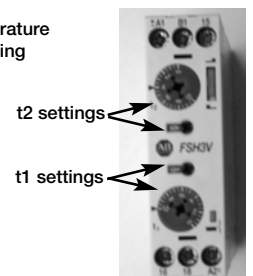

### Step 8 Put the Unit into Service

Remove the jumper, and energize the blower(s). Verify proper operation.

### IMPORTANT!

Check the media for minerals after two weeks of service and adjust the bleed-off rate accordingly.

# Start-Up - Water Wizard (Optional)

## Step 1 Open the Solenoid

Confirm that the manual water supply valve is closed. Press and hold the function button for one second. L3 will begin blinking (short on, long off), indicating that flow test mode is active and the supply solenoid is open.

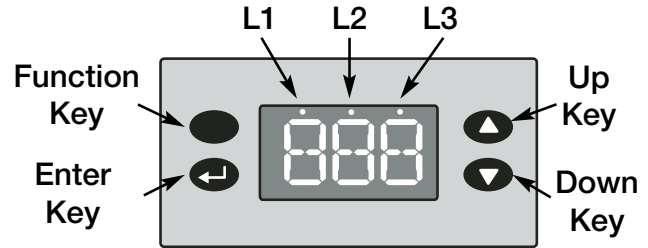

### WARNING!

Opening the manual supply valve will allow water to pass to the media. Be sure the sump is safely draining before opening the manual supply valve.

S-11

## Step 2 Set the Water Pressure

With the solenoid open, set the supply water pressure to the correct setting from the following tables. Use the manual supply valve to adjust the supply pressure. A pressure gauge is provided between the manual supply valve and the media.

### NOTE!

The manual supply valve ships closed and must be adjusted for proper performance.

One Sided Evaporative Coolers	
Housing	Water Pressure (in. w.c.)
H 40	51

Three Sided Evaporative Coolers		
Housing	Water Pressure (in. w.c.)	
	Front	Sides
H 40	30	21
H 50	21	26

### NOTE!

Three sided evaporative coolers have two manual supply valves. Each valve has a different pressure setting which must be set.

## Step 3 Break-in Media

Leave the supply solenoid open to saturate and break-in the media for 20 minutes with the blowers off.

# Start-Up - Water Wizard (Optional)

## Step 4 Close Solenoid

With the pressure set, press the function key for one second to deactivate flow test mode and allow the supply solenoid to close.

## Step 5 Check Media

Start the cooling cycle and check the media after one hour of operation. If the media is continuously dry or if too much water is draining from the sump tank, refer to Water Wizard troubleshooting.

### NOTE!

Steps 6-8 are provided to adjust the minimum cooling temperature. The minimum cooling temperature is preset to the factory recommended 75°F. Only adjust if needed.

S - 12

### NOTE!

The inlet air sensor function overrides and shuts down the evaporative cooler if the outside temperature falls below the minimum cooling temperature.

## Step 6 Enter Program Mode

Press and hold the enter key for three seconds. The display will read "Pro" when program mode is active.

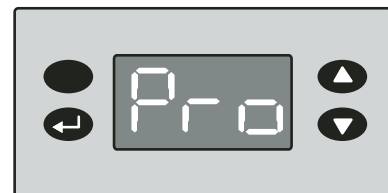

## Step 7 Adjust the Minimum Cooling Temperature

While in the program menu, use the up and down keys to navigate the menu options until "toF" is displayed. Press the enter key to access the selected menu option setting. Use the up and down keys to adjust the minimum cooling temperature as needed. Press the enter key to save the new minimum cooling temperature setting and return to the program menu.



### IMPORTANT!

The enter key must be pressed to save the new minimum cooling temperature.

# Start-Up - Water Wizard (Optional)

## Step 8 Exit Program Mode

After ten seconds of idle time the controller will exit program mode.

### NOTE!

Steps 9-11 are provided to adjust the freeze temperature setting. The freeze temperature is preset to the factory recommended 45°F. Only adjust if needed.

### NOTE!

The freeze temperature is the temperature at which the supply solenoid closes and the drain solenoid opens to drain the supply line, preventing possible freeze damage.

S - 13

## Step 9 Enter Program Mode

Press and hold the enter key for three seconds. The display will read "Pro" when program mode is active.

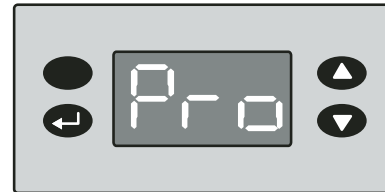

## Step 10 Adjust the Freeze Temperature

While in program mode, use the up and down keys to navigate through the menu options until "Frt" is displayed. Press the enter key to access the selected menu option setting. Use the up and down keys to adjust the freeze temperature setting as needed. Press the enter key to set the freeze temperature and return to the program menu.

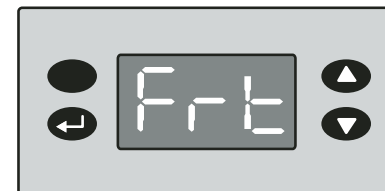

### IMPORTANT!

The enter key must be pressed to save the new freeze temperature.

## Step 11 Exit Program Mode

After ten seconds of idle time the controller will exit program mode.

# Operation - Recirculating / VAV Units

## Burner Bypass Damper

The self-adjusting burner bypass damper is a device used in variable volume and recirculation units. Its function is to maintain proper combustion by providing a constant airflow over the burner when outside air volumes are changed. It is located underneath the burner as shown in the picture below.

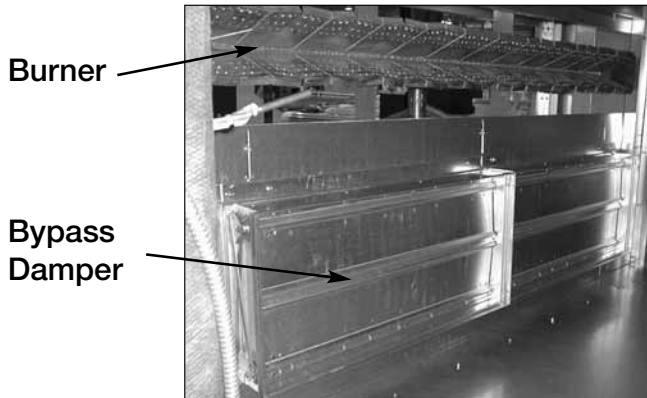

### WARNING!

The burner bypass damper is set-up at the factory. The weights and springs should not be adjusted in the field. The damper may not fully close during minimum outside air mode.

## 80/20 Operation (Optional)

### Manual Quadrant Damper Control

A manual quadrant damper in the return airflow controls the amount of recirculated air. This damper can be adjusted by hand and locked in position for either 100% outside air or maximum recirculation air.

### 2-Position Damper Control

A 2-position spring return actuator is used to control the return air amounts. The damper moves from open to closed. If power is cut to the unit, the damper will fail close. The volume of recirculation air is set in the factory by baffles in the return air opening. These baffles should not be removed or adjusted in the field.

### Potentiometer Control

A modulating spring return actuator is used to control the return air amounts. The damper moves from fully open to fully closed. The amount of return air is determined by the position of a remote potentiometer.

### Building Pressure Control

A modulating spring return actuator is used to control the return air amounts according to input from a pressure sensing device. The recirculation damper moves from fully open to fully closed.

## Variable Volume Operation (Optional)

### 2-Speed Control

A 2-speed motor is used to control air volumes. The motor can be switched to low or high speed from a remote control panel. One-half or one-third reduction motors are used.

### Potentiometer Control

A variable frequency drive is controlled by input from a remote speed selector (potentiometer). This unit allows easy manual adjustment of make-up air volumes.

### Building Pressure Control

A variable frequency drive is controlled according to input from a pressure sensing device.

### Variable Frequency Drives

For maintenance issues associated with the variable frequency drives, please consult the drive's manual supplied with the unit. The drives are programmed in the factory and should not need any adjustment during installation and start-up. For kitchen applications, the drive is typically located in the kitchen, not in the unit.

# Operation - Electrical

## Electrical Sequence

### 1. Exhaust Fan Switch (S1) Closed

- Power passes to exhaust starter(s) ST2(3)
- N.O. exhaust starter switches are energized and closed
- Power passes to exhaust fans
- Exhaust fans start

### 2. Supply Fan Switch (S2) Closed

- N.O. contact(s) ST2(3) are closed
- Power passes to optional freeze protection relay (FZ1) and if temperature is acceptable N.C. contact (FZ1) remains closed
- Power passes to damper which opens
- When damper is fully opened, damper relay (D1) is energized and N.O. damper limit switch (DL1) closes.
- Power passes to and energizes supply starter relay (ST1)
- Supply starter contact (ST1) closes and power reaches and energizes supply fan
- Supply fan starts

### 3. Heat Switch (S3) Closed

- Power passes to N.O. ST1 which is energized and closed
- Power passes to inlet air sensor contact (TS1) which is energized and closed if proper inlet air temperature is present
- Power passes to and energizes heat relay (R2)
- N.O. heat relay contact (R2) closes
- Power passes to and energizes terminal 5 of the Flame Safe Guard (FSG)
- Power passes to N.C. high limit control contact (HLC1) which is closed if the temperature remains below the set point
- Power passes to N.O. and N.C. gas pressure contacts (PS1) which are both closed if gas pressure is within the set range
- Power passes to terminal 6 of the FSG
- FSG begins direct gas burner sequence (see direct gas sequence)

### 4. Evaporative Cooling Switch (S4) Closed\*

- N.O. contact ST1(AUX) is energized and closed
- Power passes to and energizes cool relay (R1)
- N.O. contact R1 is energized and closed
- Power passes to evaporative cooling pump (P1)

\*If DX or chilled water coils are used rather than an evaporative cooler, the cooling sequence of operation will depend on the coil controls. Cooling coil controls are supplied by others.

## Direct Gas Burner Sequence

### 1. Supply Fan Switch Closed

- Power passes to the supply fan and heat switch

### 2. Heat Switch Closed

- Power passes to the heat relay then to the Flame Safe Guard

### 3. Flame Safe Guard (FSG) Sequence

- Checks for proper airflow
- Verifies no flame present at burner
- Initiates 10 second prepurge
- Sends power to open pilot valve (V1) and energizes the spark generator (SG1) (clicking of the spark generator may be heard).
- Tries for up to 10 seconds to light pilot and confirm flame.
- Powers the main gas valves (V2 and V3) open
- Shuts down spark generator
- Continuously monitors the flame and airflow
- Performs self-diagnostic check every five seconds

# Operation - Water Wizard

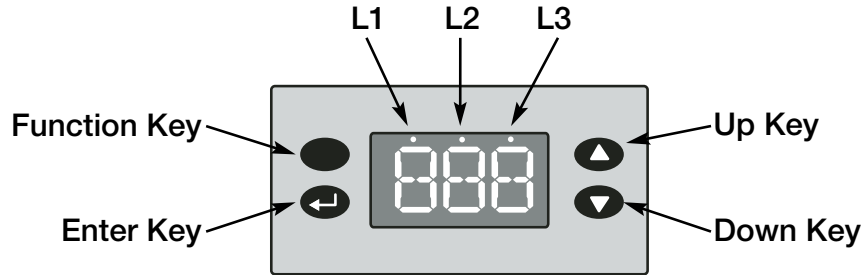

## Key Functions

### Drain Mode

Drain mode locks open the drain solenoid and drains the supply line between the supply solenoid and the media. To activate drain mode simultaneously press the function and enter keys (L2 will light). To deactivate drain mode and unlock the drain solenoid, simultaneously press the function and enter keys again.

### Flow Test Mode

Activating flow test mode opens the supply solenoid and allows water to pass to the manual supply valve. To activate flow test mode, press and hold the function key for one second (L3 will flash). To deactivate flow test mode and allow the supply solenoid to close, press and hold the function key again for one second.

#### CAUTION!

The sump drain line must be clear and draining to a safe location before using flow test mode.

#### CAUTION!

Be aware of the water level in the sump tank at all times when using the flow test mode.

### Program Mode

Program mode allows the user to view the program menu and edit the factory default settings. To access program mode and view the program menu press and hold the enter key for three seconds. While viewing the program menu press the up and down keys to scroll through the menu options. To view the setting of the selected menu option press the enter key. To edit the setting, press the up or down key while viewing the setting. To save the setting and return to the program menu press the enter key. To return to the program menu without saving the change, wait 10 seconds. To exit program mode from the program menu, wait 10 seconds.

#### WARNING!

Changing the default settings will significantly affect performance. Only change a setting after reading and understanding this entire manual.

#### NOTE!

The enter key must be pressed to save any changes made to a setting.

### Dry Bulb Temperature

The default display is the dry bulb temperature of the outside air.

### Wet Bulb Temperature

To view the wet bulb temperature, simultaneously press and hold the up and down keys.

### Indicating Lights

Three indicating lights are located across the top of the display to indicate the status of the Water Wizard.

	Light Status			
	On	Off	Blinking (Long on, short off)	Blinking (Short on, long off)
L1	Call For Cooling	No Call For Cooling	N/A	N/A
L2	Drain Solenoid Open	Drain Solenoid Closed	N/A	N/A
L3	Cooling On	Cooling Off	Supply Solenoid Locked Closed	Flow Test Mode Active

# Troubleshooting

## Blower Does Not Operate

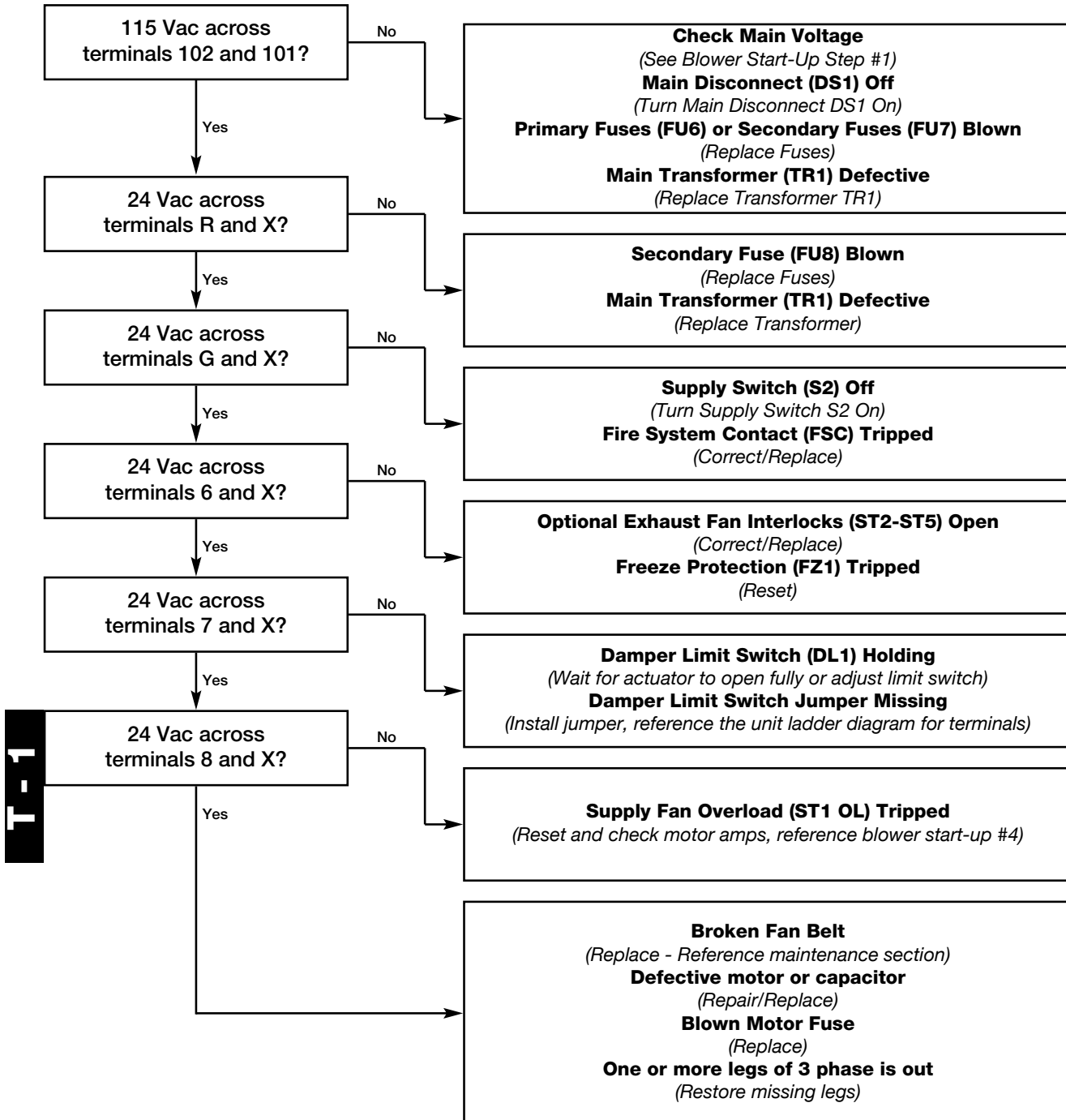

**Note:** At this time the supply contactor (ST1) should pull in passing power to the supply motor and the blower should start.

# Troubleshooting

## Heater Does Not Operate

Does not attempt to light (No visible spark)

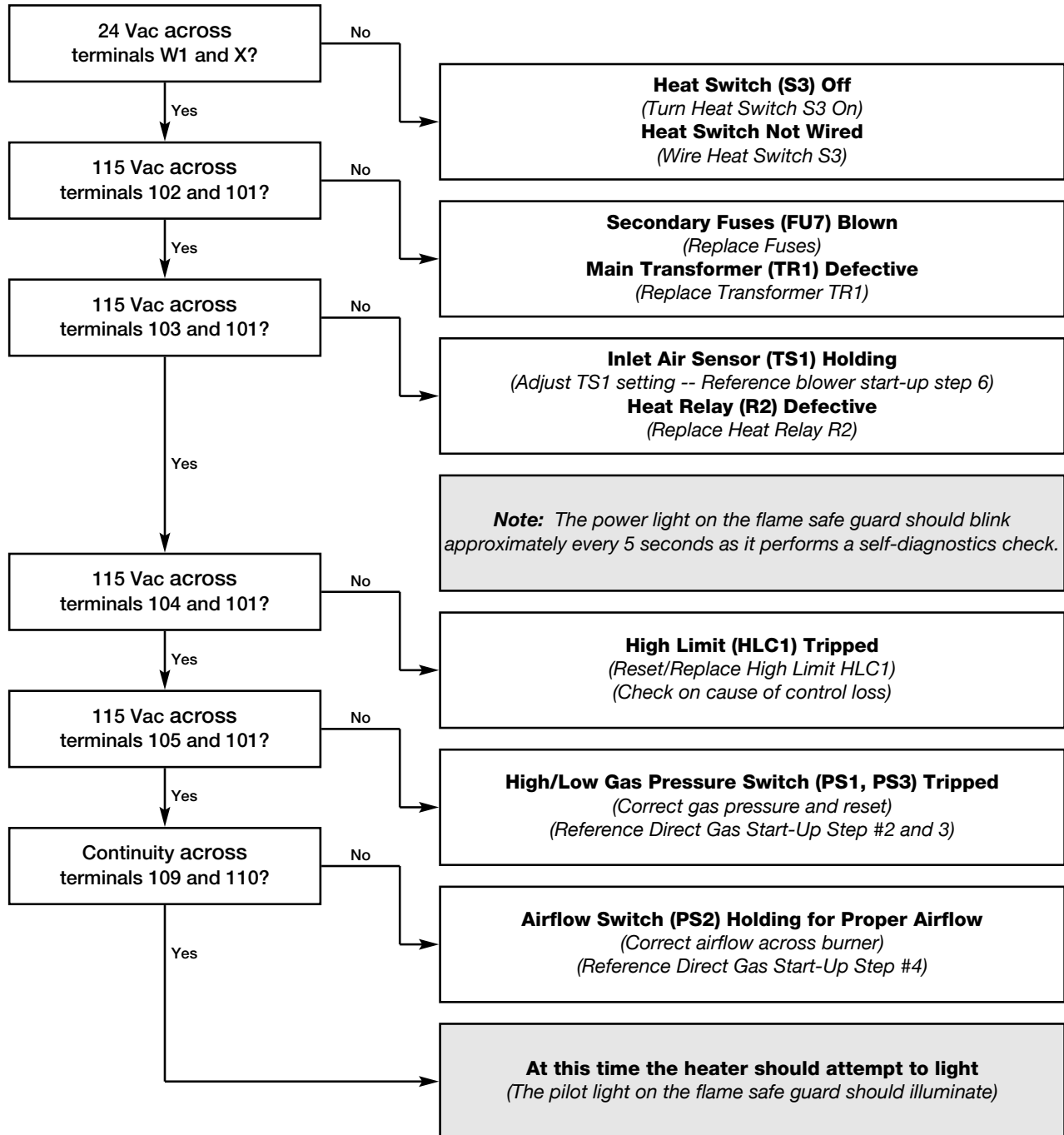

# Troubleshooting

## Heater Does Not Operate

Attempts to light but no visible pilot (Visible spark)

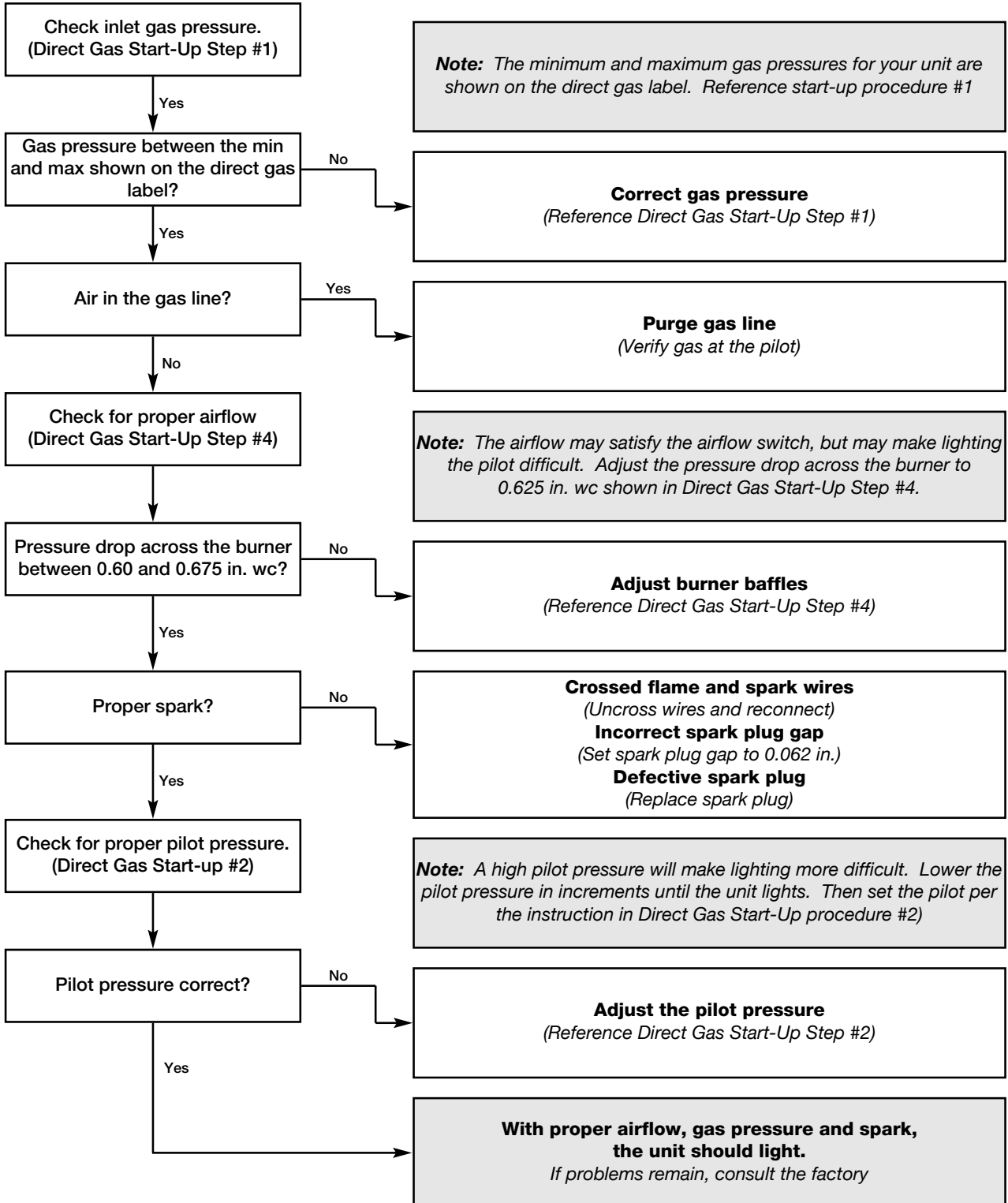

T-3

# Troubleshooting

## Heater Does Not Operate

Visible pilot

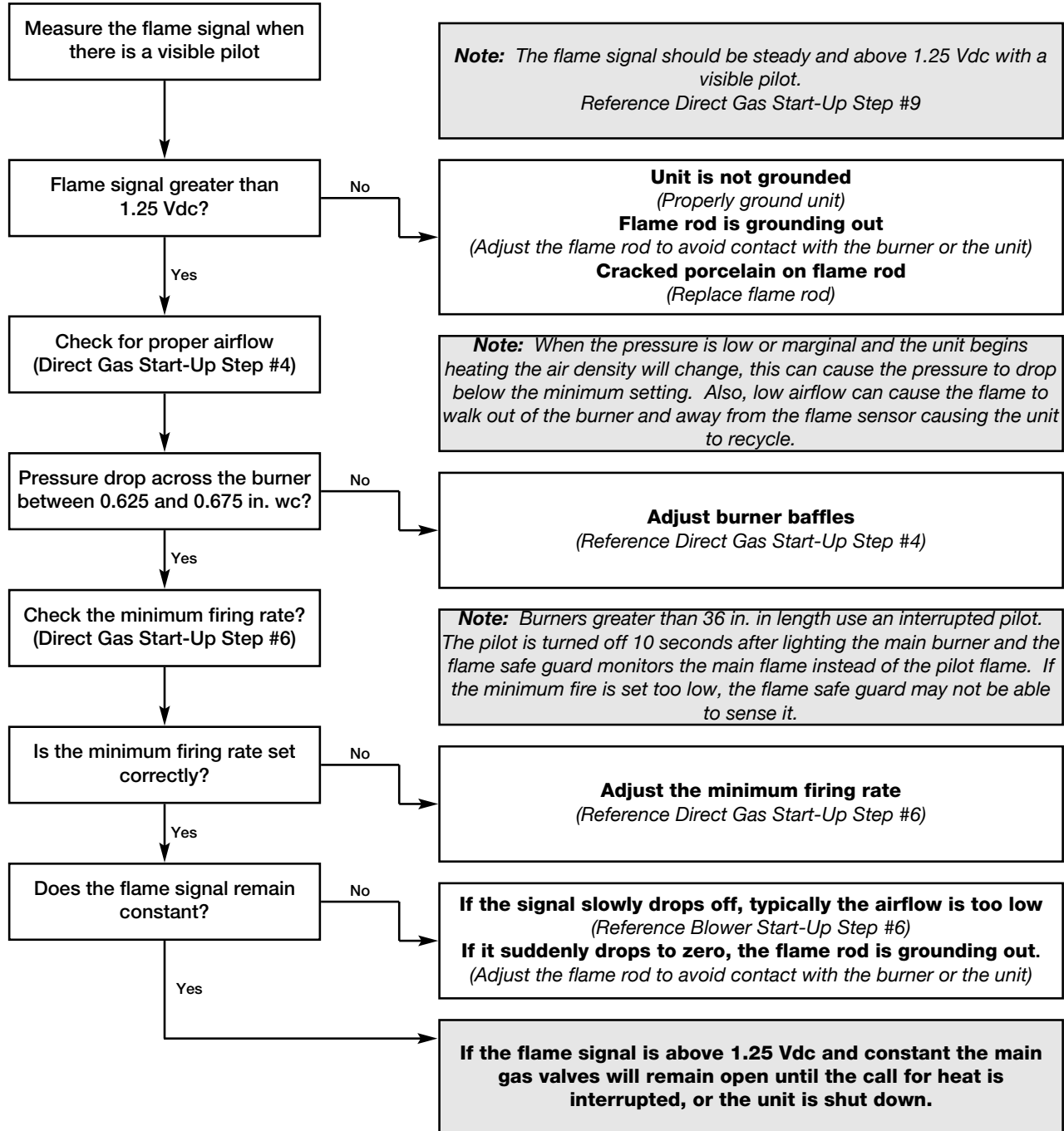

# Troubleshooting

## Excessive Noise or Vibration

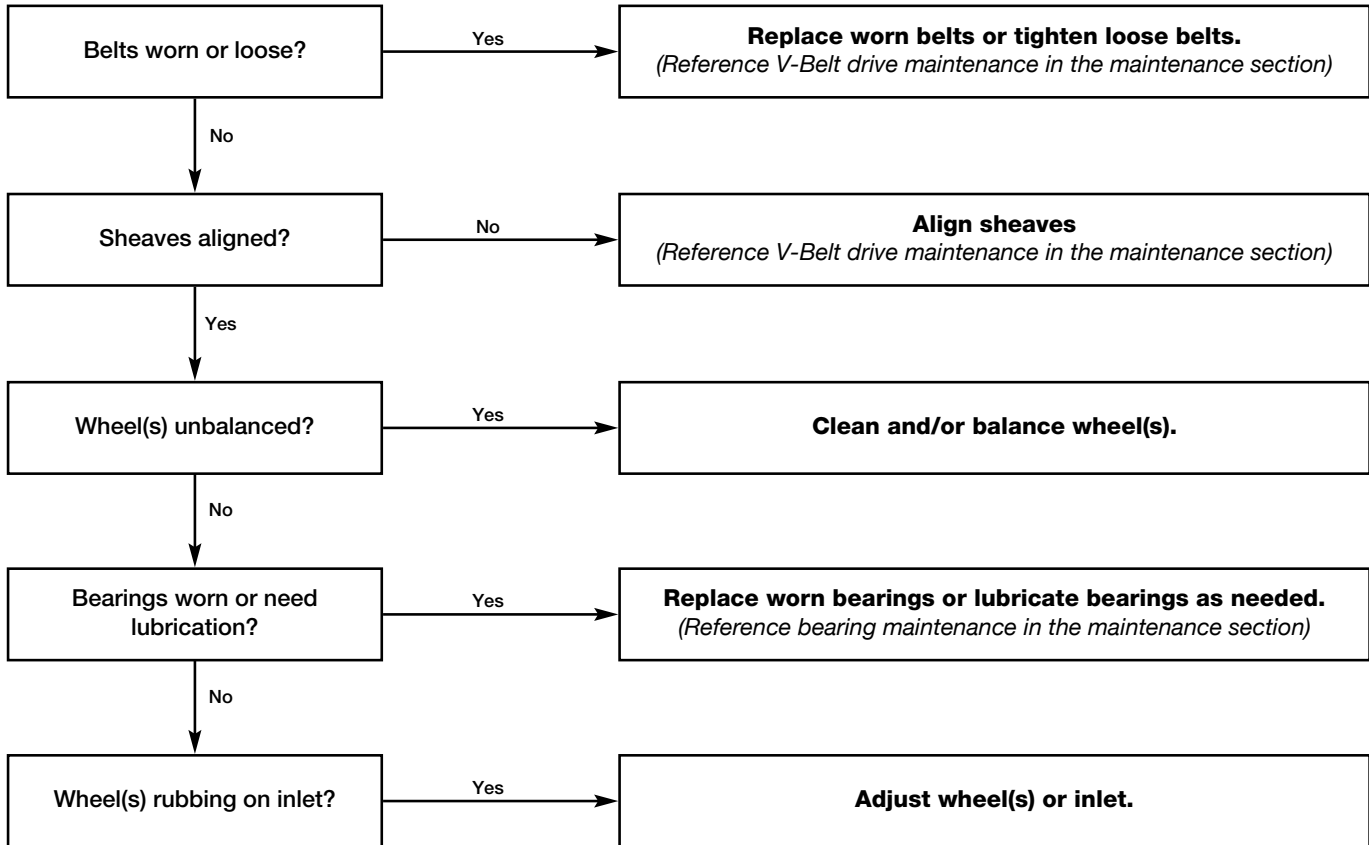

**Note:** At this time noise and vibration should be at acceptable levels.

# Troubleshooting

## Water Blows through Evaporative Cooler

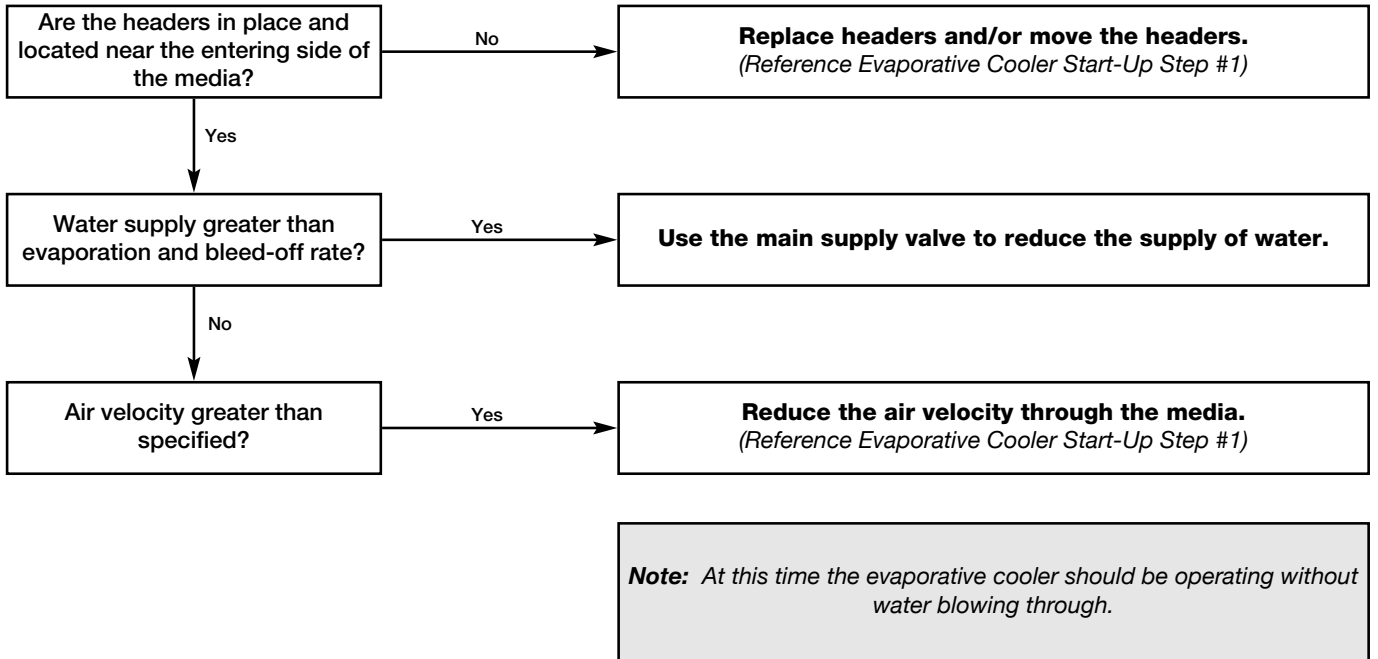

# Troubleshooting

## Water Wizard Water Supply

### NOTE!

If the water supply is too low, the media will continuously appear dry.

### NOTE!

If the water supply is too high, the media will be saturated and excessive water will be draining from the sump tank.

### NOTE!

Some water drainage is desired to keep the media flushed, but it should be minimized to utilize the Water Wizard.

### Step 1 Adjust the Manual Supply Valve

Adjust the manual supply valve (refer to Water Wizard Start-Up Step #2). If the recommended water pressure does not provide enough water, increase the pressure until the desired water supply is achieved. If the recommended water pressure provides too much water, decrease the water pressure until the desired water supply is achieved.

### CAUTION!

Only proceed to steps two and three if step one does not correct the problem.

### Step 2 Enter Program Mode

Press and hold the enter key for three seconds to enter program mode. The display will read "Pro" when program mode is active.

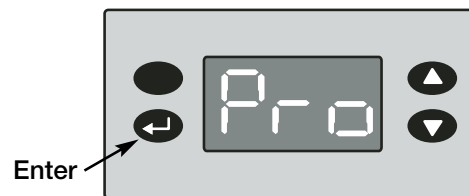

### Step 3 Adjust the On Time Factor

While in the program menu, use the up and down keys to navigate through the menu options until "ont" is displayed.

With "ont" displayed, press the enter key to access the setting.

With the setting displayed, use the up and down keys to adjust the setting as needed.

Increase the factor to increase the water supply or decrease the factor to decrease the water supply.

Press the enter key to save the new on time factor and return to the program menu.



### NOTE!

Changing the on time factor by (1) will change the water supply by approximately 3%.

### IMPORTANT!

The enter key must be pressed to save the new on time factor.

### Step 4 Exit Program Mode

After ten seconds of idle time the controller will automatically exit program mode.

# Maintenance - Routine

## CAUTION!

Lock-out the gas and the electrical power to the unit before performing any maintenance or service operations to this unit.

### V-Belt Drives

V-belt drives must be checked on a regular basis for wear, tension, alignment and dirt accumulation.

Check the alignment by using a straight edge across both sheaves as shown below.

Check the tension by measuring the deflection in the belt as shown below.

## IMPORTANT!

Premature or frequent belt failures can be caused by improper belt tension, or misaligned sheaves.

Abnormally high belt tension or drive misalignment will cause excessive bearing loads and may result in failure of the fan and/or motor bearings.

Abnormally low belt tension will cause squealing on start-up, excessive belt flutter, slippage and overheated sheaves

## IMPORTANT!

Do not pry belts on or off the sheave. Loosen belt tension until belts can be removed by simply lifting the belts off the sheaves.

## IMPORTANT!

When replacing V-belts on multiple groove drives all belts should be changed to provide uniform drive loading.

## IMPORTANT!

Do not install new belts on worn sheaves. If the sheaves have grooves worn in them, they must be replaced before new belts are installed.

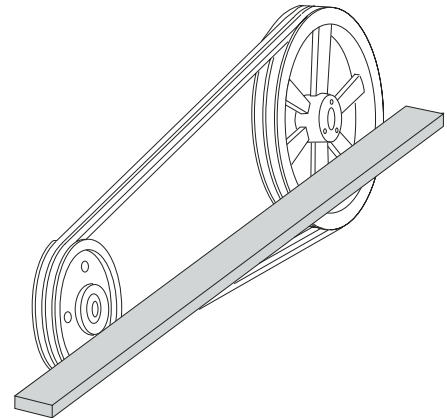
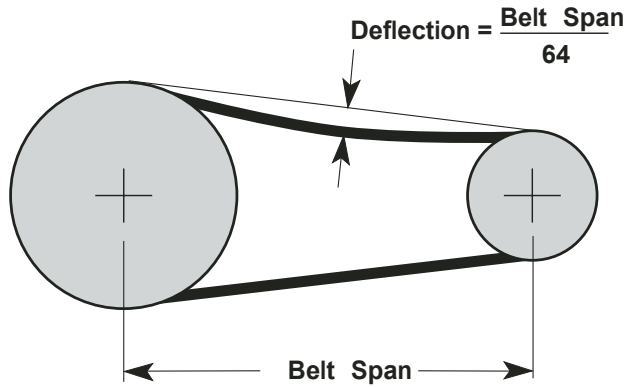

# Maintenance - Routine

## Motors

Motor maintenance is generally limited to cleaning and lubrication (where applicable).

Cleaning should be limited to exterior surfaces only. Removing dust and grease build-up on the motor assures proper motor cooling.

Motors supplied with grease fittings should be greased in accordance with the manufacturer's recommendations.

### IMPORTANT!

**Do not allow water or solvents to enter the motor or bearings. Motors and bearings should never be sprayed with steam, water or solvents.**

### IMPORTANT!

**Greasing motors is only intended when fittings are provided. Many motors are permanently lubricated, requiring no additional lubrication.**

## Wheels

Wheels require little attention when moving clean air. Occasionally oil and dust may accumulate on the wheel causing imbalance. When this occurs the wheel and housing should be cleaned to assure proper operation.

## Bearings

The bearings for Greenheck fans are carefully selected to match the maximum load and operating conditions of the specific class, arrangement and fan size. The instructions provided in this manual and those provided by the bearing manufacturer will minimize any bearing problems.

### IMPORTANT!

**Lubricate bearings prior to periods of extended shutdowns or storage and rotate shaft monthly to aid in corrosion prevention. If the fan is stored more than three months, purge the bearings with new grease prior to start-up.**

## Recommended Bearing Lubrication Schedule for Greenheck Fans

Relubrication Schedule in Months\*

Fan RPM	Bearing Bore Size (inches)				
	1/2 - 1	1 1/8 - 1 1/2	1 5/8 - 1 7/8	1 15/16 - 2 3/16	2 7/16 - 3
250	6	6	6	6	6
500	6	6	6	5	4
750	6	5	4	3	3
1000	5	3	2	1	1
1250	5	3	2	1	1
1500	5	2	1	1	0.5
2000	5	1	1	0.5	0.25

\* Suggested initial greasing interval is based on 12 hour per day operation and 150°F maximum housing temperature. For continuous (24 hour) operation, decrease greasing interval by 50%

- If extended grease lines are present, relubricate while in operation, only without endangering personnel.
- For ball bearings (operating) relubricate until clean grease is seen purging at the seals. Be sure not to unseat the seal by over lubricating.
- For ball bearings (idle) add 1-2 shots of grease up to 2 inch bore size, and 4-5 shots above 2 inch bore sizes with a hand grease gun.
- For roller bearings add 4 shot of grease up to 2 inch bore size, and 8 shots for 2 inch - 5 inch bore size with a hand grease gun.
- Adjust relubrication frequency based on condition of purged grease.
- A high quality lithium based grease conforming to NLGI Grade 2 consistency, such as those listed below should be used:

*Mobil 532*

*Texaco Multifak #2*

*B Shell Alavania #2*

*Mobilux #2*

*Texaco Premium #2*

*Exxon Unirex N2*

# Maintenance - Routine

## Filters

Filter maintenance is generally limited to cleaning and replacement.

If aluminum mesh filters are installed, they can be washed in warm soapy water.

An adhesive spray can be added to aluminum mesh filters to increase their efficiency.

If disposable filters are installed, they can be checked by holding up to a light source. If light cannot pass through the filter, it should be replaced.

## Evaporative Coolers

The media should be periodically brushed lightly with a soft bristle brush in an up and down motion while flushing with water. This aids in reducing the amount of mineral build-up.

For large amounts of mineral build-up, clean or replace the media and increase the water bleed-off or flush rate.

The cooling media has a useful life of 3 to 5 years depending on the water quality and the bleed-off or flush rate.

### **IMPORTANT!**

**Replacement media should be from the same manufacturer and be the same size as the original media provided with the unit.**

### **IMPORTANT!**

**When reinstalling filters be sure to install them with the airflow in the correct direction. An airflow direction arrow is located on the side of the filters.**

### **IMPORTANT!**

**Replacement filters should be from the same manufacturer and the same size as the original filters provided with the unit.**

### **IMPORTANT!**

**When reinstalling the evaporative media, make sure that it is installed correctly. Reference the drawing shown below.**

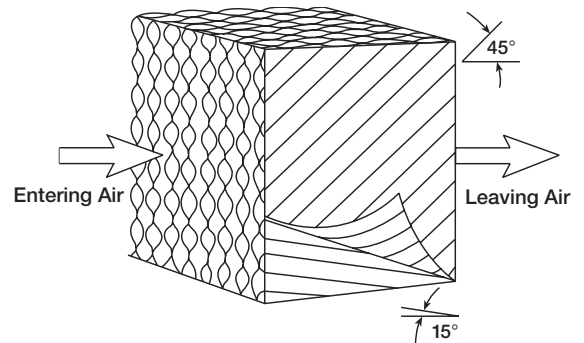

# Maintenance - Fall

## Start-Up

Repeat the Blower Start-Up procedure #5 and Direct Gas Start-Up procedure #1, 2 and 4. This will ensure that the gas and air are set properly before the heating season begins, and should lead to trouble free operation all winter.

## High Limit

The high limit switch may have tripped over the summer, it should be checked and reset if necessary.

## Burner

Inspect the burner for accumulation of scales on both the upstream and downstream sides of the mixing plates. Any scaling or foreign material should be removed with a wire brush.

Visually check that all holes in the mixing plates are clear. If any burner ports are plugged (even partially), clear them with a piece of wire or another appropriate tool.

Replace or tighten any loose or missing fasteners on the mixing plates. Always use zinc plated or stainless steel fasteners.

Inspect and clean the flame and spark rod. Occasional replacement of the flame rod and spark rod may be necessary to ensure optimum unit performance.

If a UV sensor is used instead of a flame rod, the sensor's lens should be cleaned at least once a year. The sensor may require more frequent cleaning, depending on the operating environment and should be checked periodically over the heating season.

### WARNING!

Do not enlarge the burner ports when clearing a blockage, performance could be affected.

### NOTE!

Flame rod life is dependent ambient conditions, annual replacement is not uncommon.

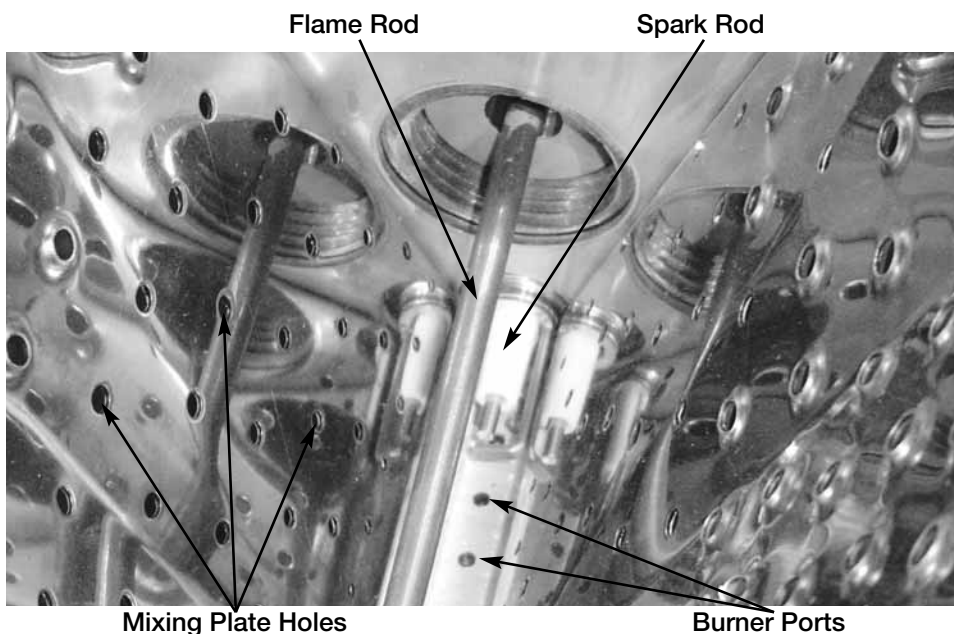

M - 4

## Evaporative Coolers

The water should be shut off and all the lines drained when the outside temperature drops below 45°F.

Remove drain plugs for the winter.

Clean all interior parts of any mineral deposits or foreign materials that may have built-up during the cooling season.

Replace any worn or non-functioning parts.





# Reference

## Typical Gas Train Layout 400 - 800 MBH

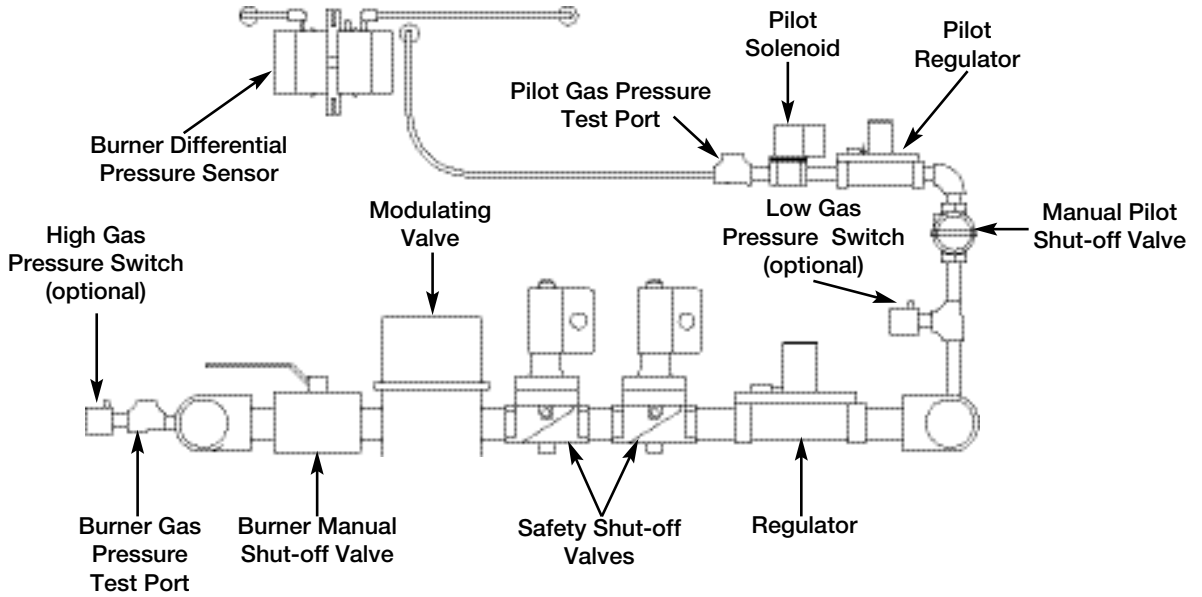

## Typical Gas Train Layout > 800 MBH

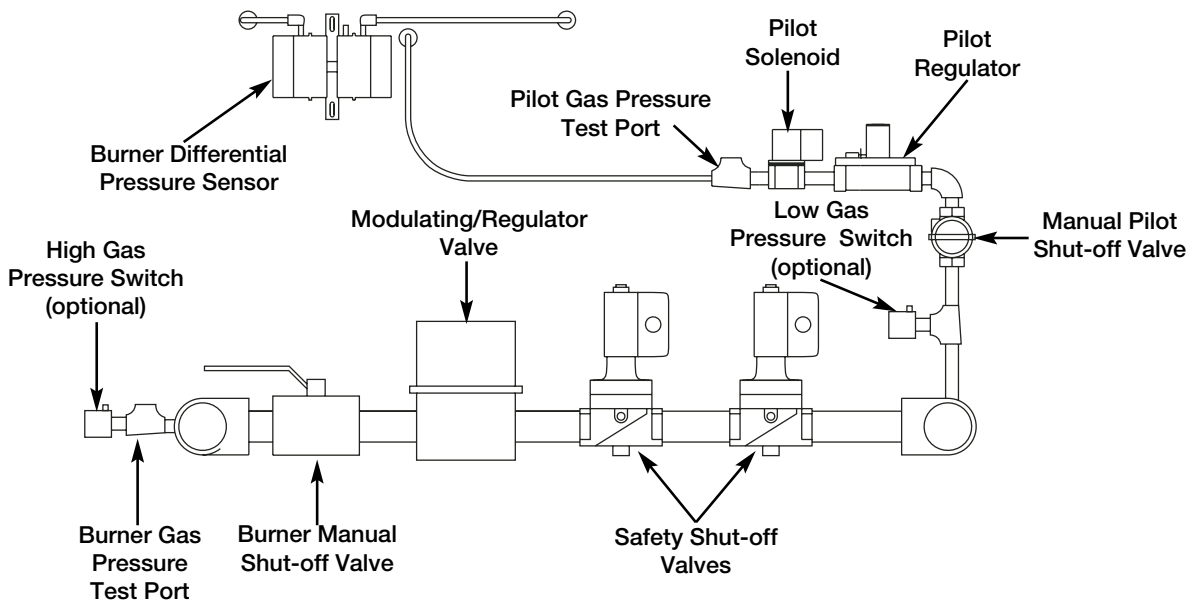

# Reference

## Control Center Layout

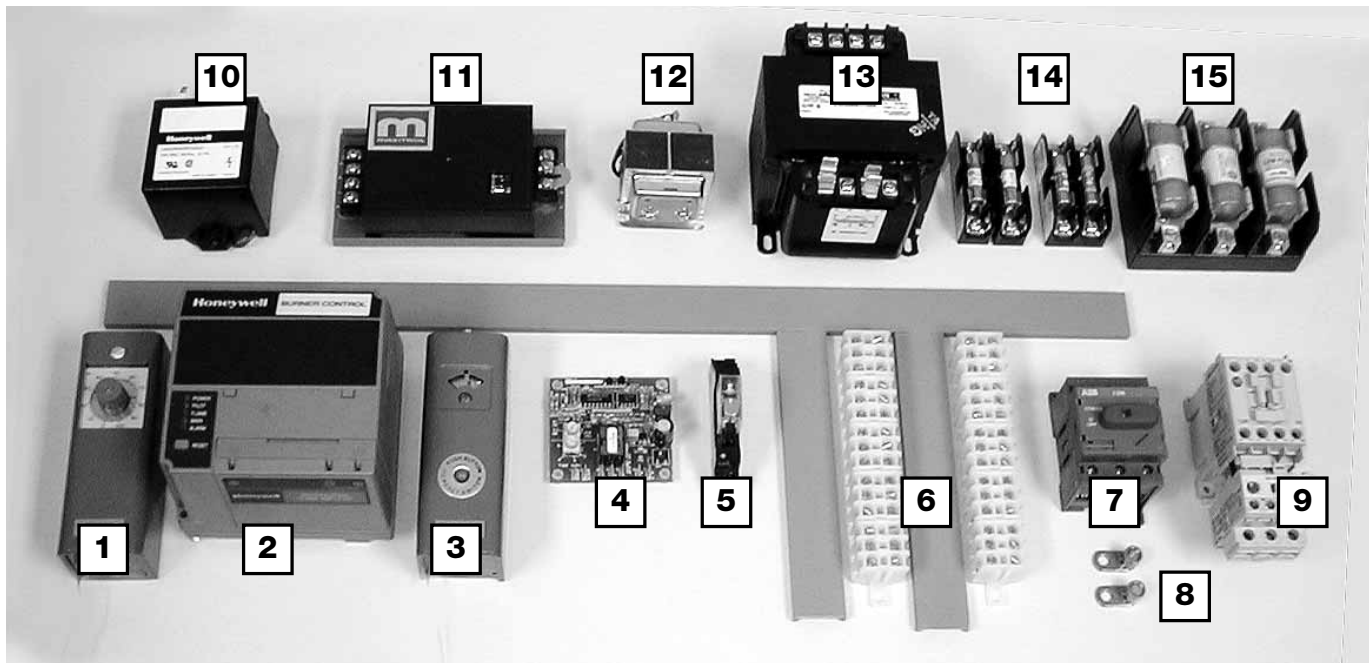

1. **Heating/Cooling Inlet Air Sensor (Optional)** - Ductstat that automatically de-energizes burner when inlet air temperature rises above set point, or shuts down cooling when temperature falls below set point.
2. **Flame Safe Guard** - Monitors flame, shuts-down unit when unsafe conditions are detected.
3. **High Limit** - Prevents unit from discharging air above a set point.
4. **Building Freeze Protection (Optional)** - Prevents unit from discharging air below a set point after a time delay.
5. **Heat/Cool Relay** - Allows power to pass to Flame Safe Guard or cooling unit.
6. **Terminal Strip** - 24 Volt power strip for control wiring.
7. **Main Disconnect** - On/Off switch, provides single point power connection to unit.
8. **Grounding Lugs** - Completes electrical circuit
9. **Motor Starters** - 24 Volt magnetic contacts for starting motors, comes standard with electronic overload, may be provided with auxiliary contacts.
10. **Spark Generator** - Causes the spark rod to spark and ignite the flame.
11. **Amplifier** - Controls modulating valve, assures the desired temperature is delivered.
12. **Low Voltage Transformer** - Reduces voltage to the Maxitrol system.
13. **Control Transformer** - Provides 24 Volts for controls.
14. **Secondary Fuses** - Provides proper fusing for all electrical components other than the motors.
15. **Motor Fuses** - Provides proper fusing for supply and exhaust fan motor(s).

### Warranty

Greenheck warrants this equipment to be free from defects in material and workmanship for a period of one year from the purchase date. Any units or parts which prove defective during the warranty period will be replaced at our option when returned to our factory, transportation prepaid.

Motors are warranted by the motor manufacturer for a period of one year. Should motors furnished by Greenheck prove defective during this period, they should be returned to the nearest authorized motor service station. Greenheck will not be responsible for any removal or installation costs.

As a result of our commitment to continuous improvement,  
Greenheck reserves the right to change specifications without notice.

***This manual is the property of the owner, and is required for future maintenance.  
Please leave it with the owner when you complete the job.***